

[54] **DISC JOCKEY'S COMBINED
PHONOGRAPH, MIXER AND CONSOLE**

[76] **Inventor: Patricia A. Marino, 1260 Madera St.,
San Diego, Calif. 92114**

[**] **Term: 14 Years**

[21] **Appl. No.: 341,468**

[22] **Filed: Jan. 21, 1982**

[52] **U.S. Cl. D14/17; D14/1;
D14/18; D14/20; D14/99**

[58] **Field of Search D14/5, 14, 15, 17, 18,
D14/20, 22-24, 1, 99**

[56] **References Cited**

U.S. PATENT DOCUMENTS

D. 154,143	6/1949	Reed	D14/20
D. 244,961	7/1977	Boldt et al.	D14/17 X
D. 260,257	8/1981	Roegner et al.	D14/18 X
D. 266,846	11/1982	Hills	D14/5 X

OTHER PUBLICATIONS

The New Yorker, 4/6/81, p. 66, Bang & Olufsen Beocenter 7000.

Primary Examiner—Jane E. Corrigan
Attorney, Agent, or Firm—Laurance E. Banghart

[57] **CLAIM**

The ornamental design for a disc jockey's combined phonograph, mixer and console, as shown and described.

DESCRIPTION

FIG. 1 is a top perspective view of a disc jockey's combined phonograph, mixer and console showing my new design;

FIG. 2 is a top plan view thereof;

FIG. 3 is a bottom plan view thereof;

FIG. 4 is a front elevational view thereof;

FIG. 5 is a rear elevational view;

FIG. 6 is a right side elevational view;

FIG. 7 is a sectional view taken along line 7—7 in FIG. 4; and

FIG. 8 is a left side elevational view.

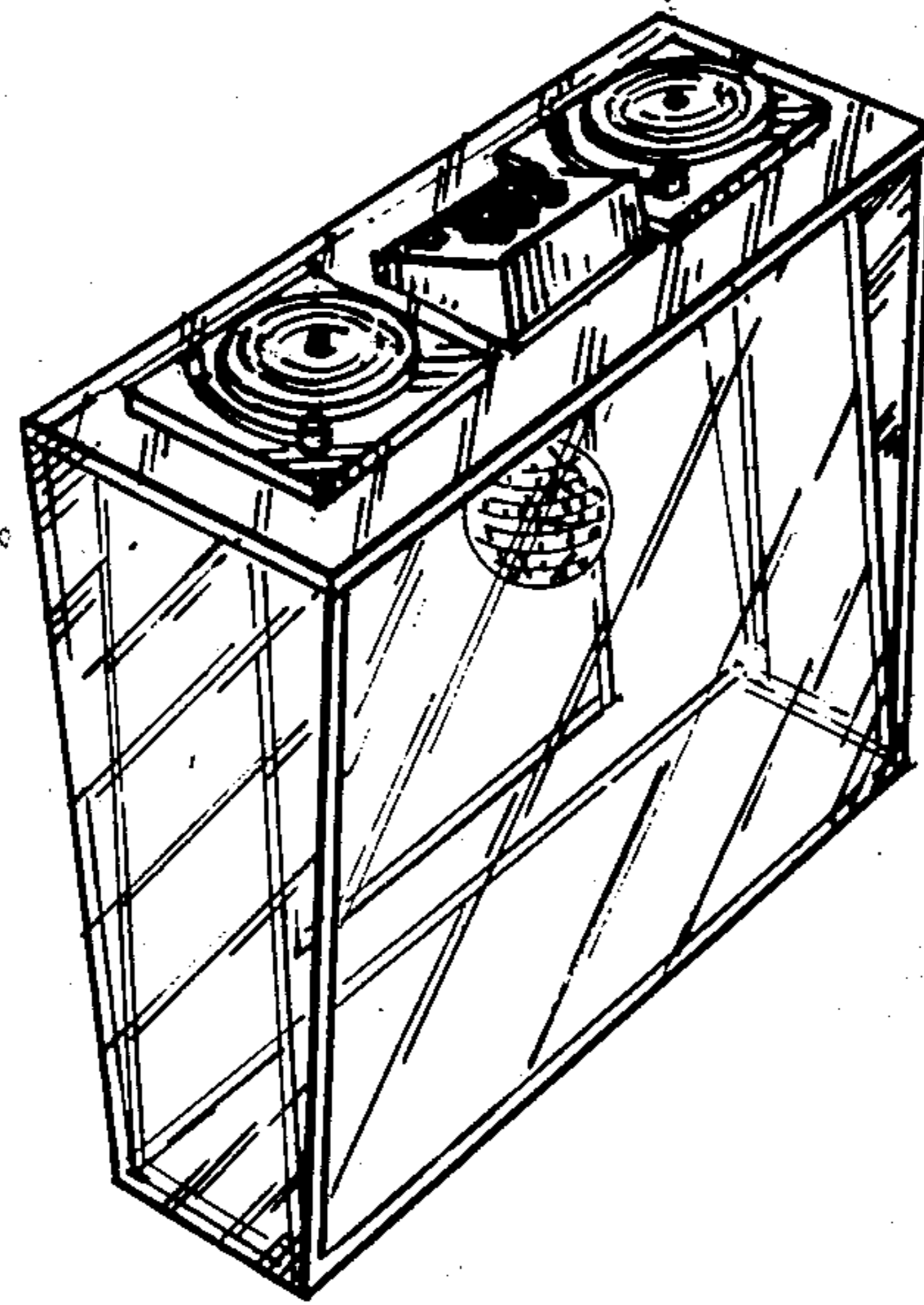

Fig. 1

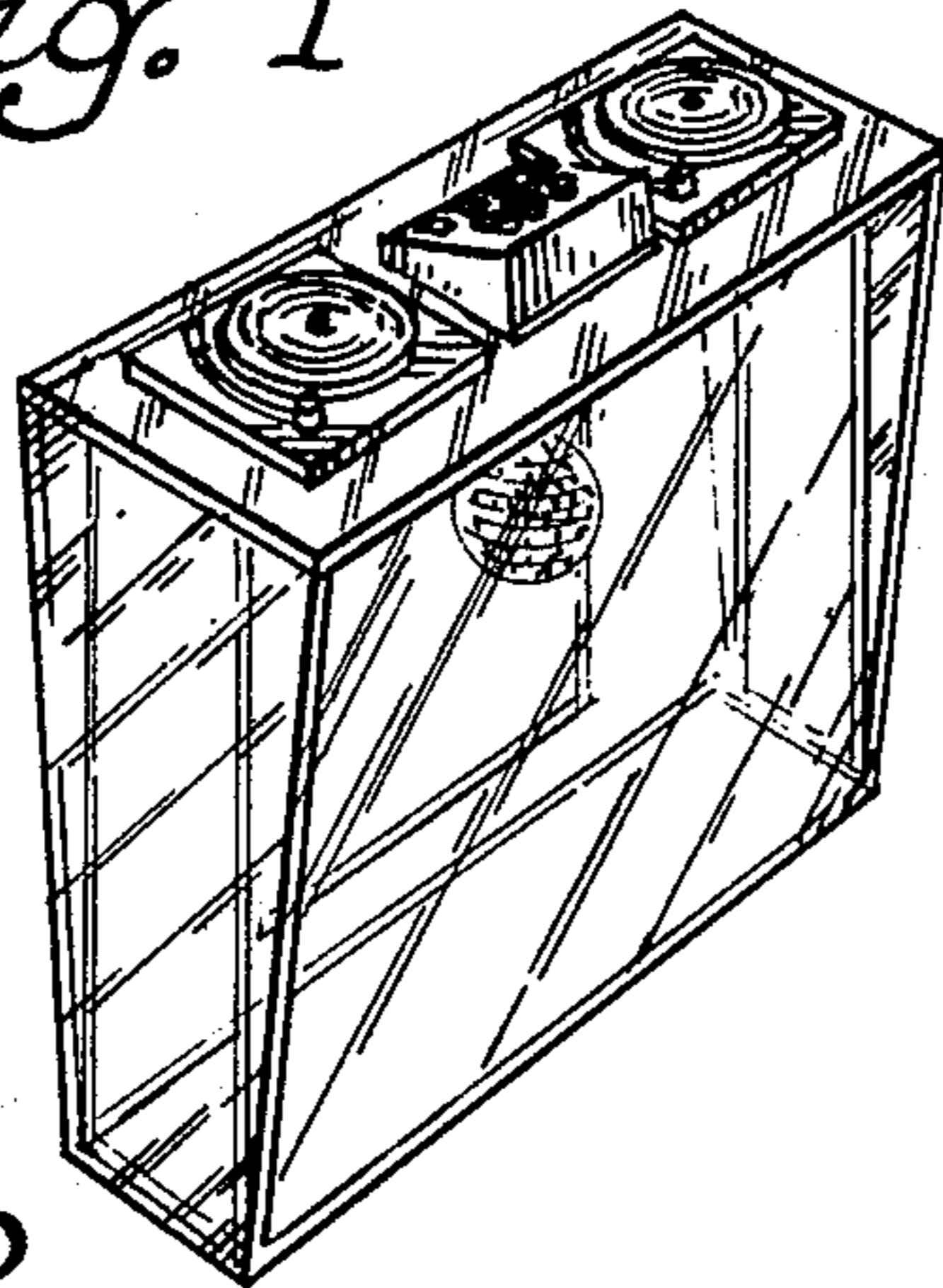

Fig. 2

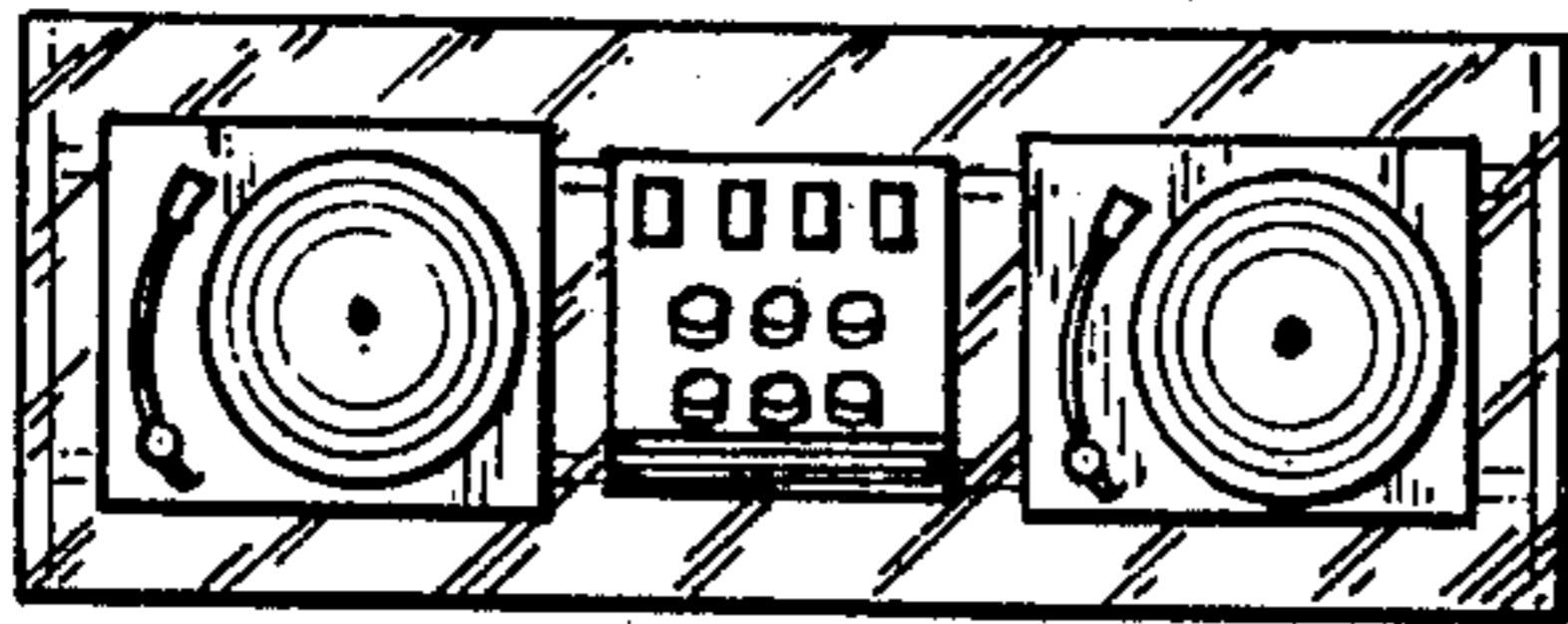

Fig. 3

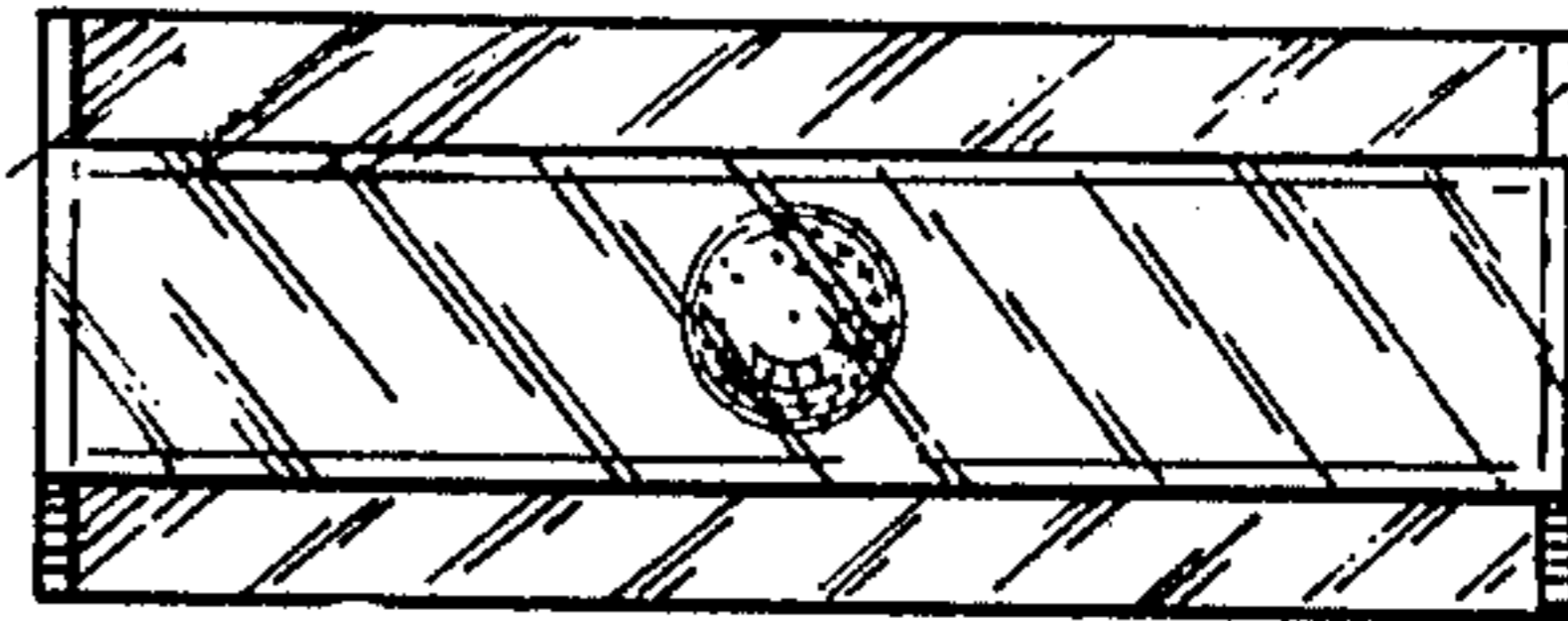

Fig. 4

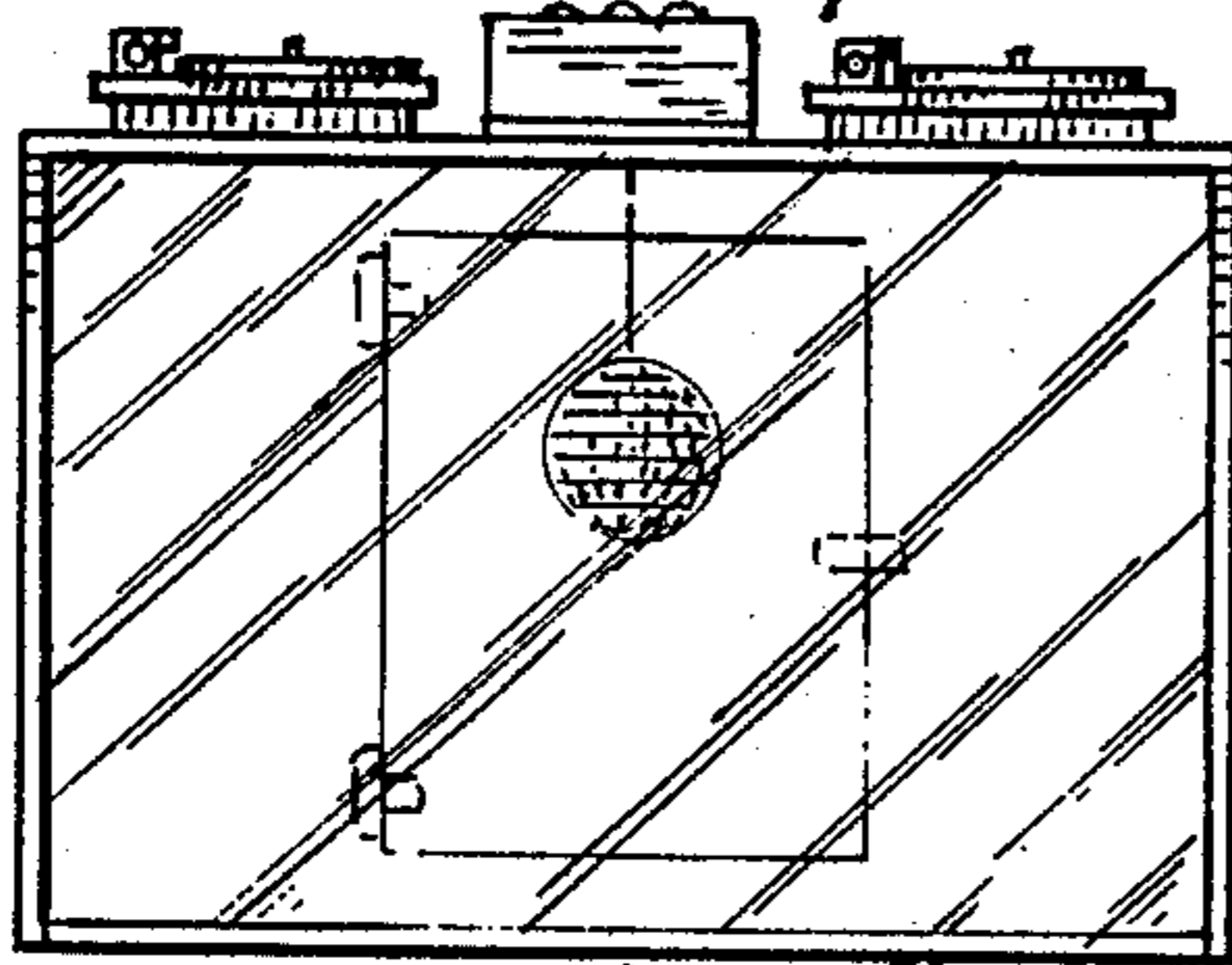

Fig. 5

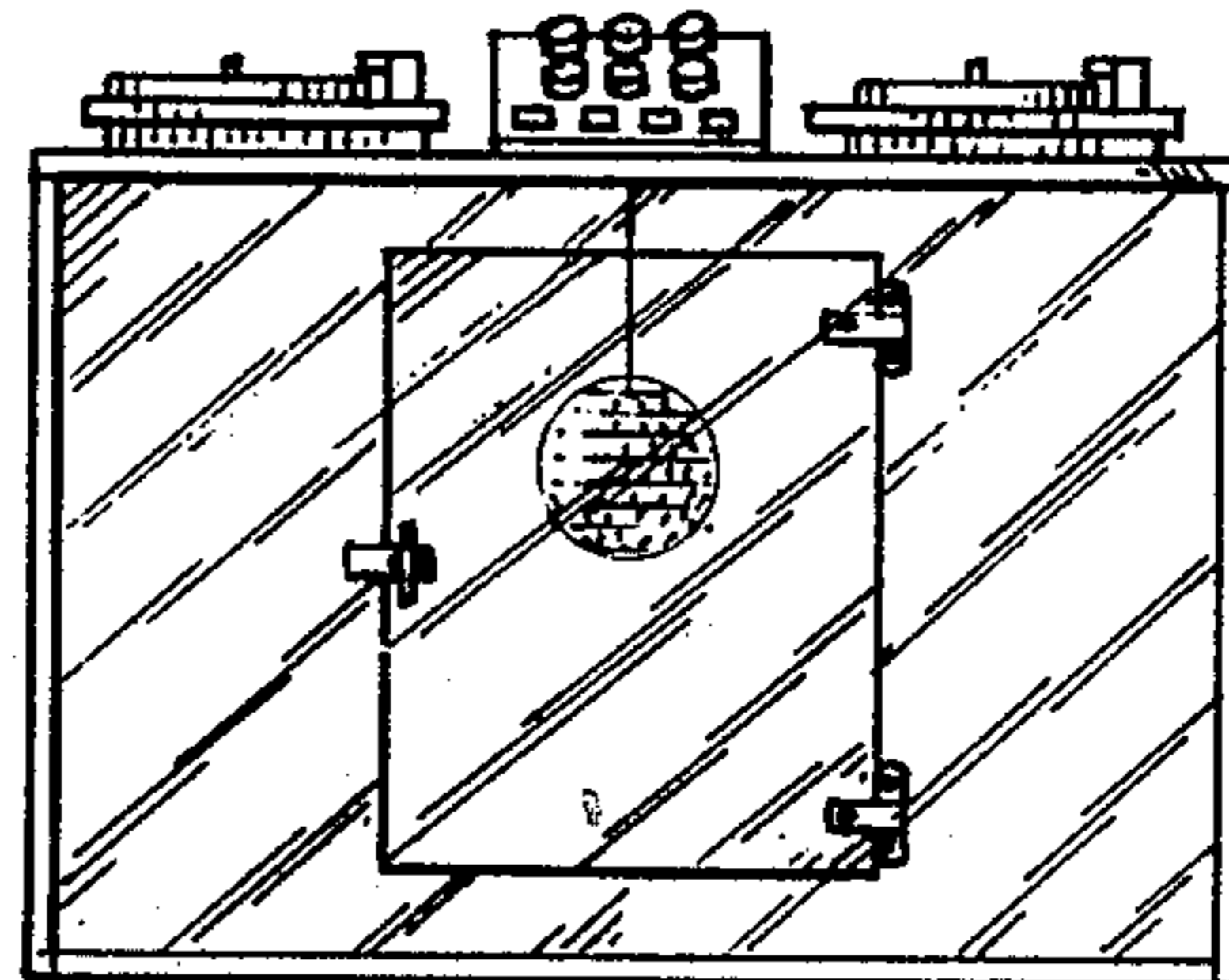

Fig. 6

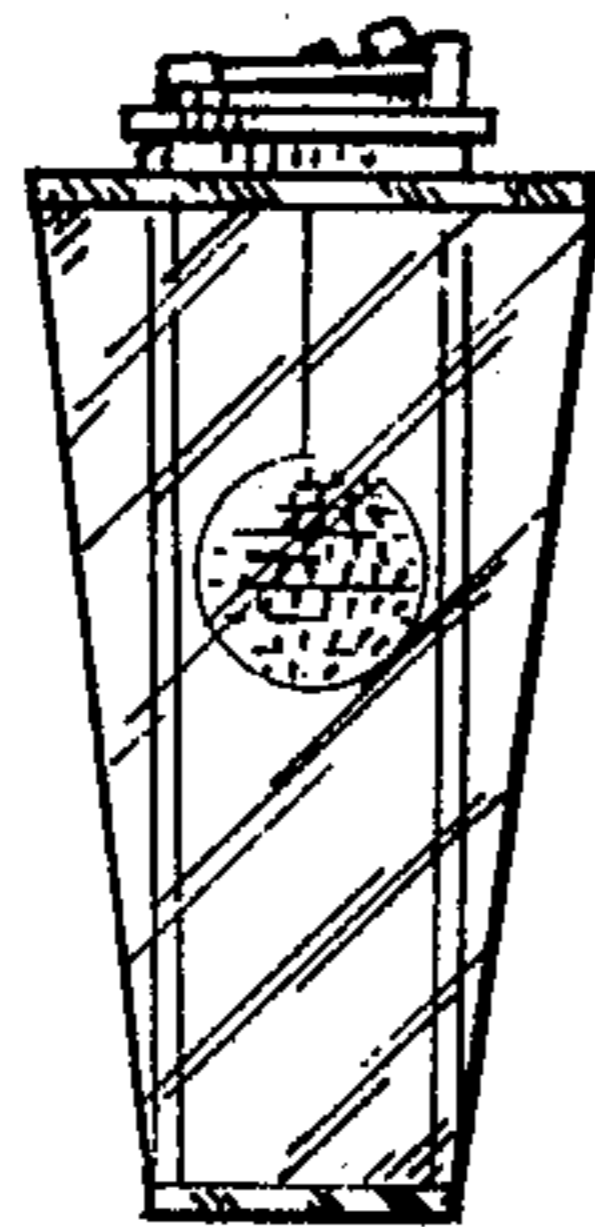

Fig. 7

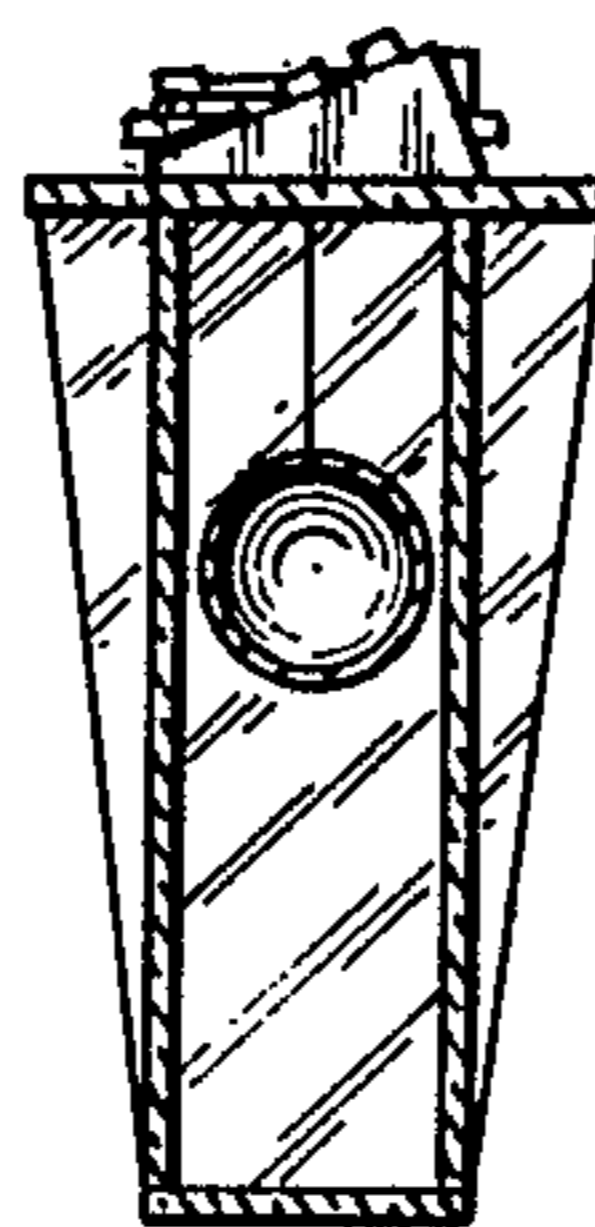

Fig. 8

