

[54] **WHEEL**

[75] **Inventor: John R. de Vries, Helmonds, Netherlands**

[73] **Assignee: AB Volvo, Gothenburg, Sweden**

[**] **Term: 14 Years**

[21] **Appl. No.: 454,850**

[22] **Filed: Dec. 30, 1982**

[30] **Foreign Application Priority Data**

Jun. 30, 1982 [SE] Sweden 82-1740

[52] **U.S. Cl. D12/211**

[58] **Field of Search D12/209, 211; 301/63 R, 301/64 R, 64 SD, 65, 66**

[56] **References Cited**

U.S. PATENT DOCUMENTS

D. 215,652 10/1969 Griffith D12/211

D. 231,732 6/1974 Ishibashi D12/209
D. 237,067 10/1975 Sandberg D12/211

OTHER PUBLICATIONS

Autocar, 10/4/75, p. 60, MK 3 Wheel, bottom left side of page.

Primary Examiner—James M. Gandy
Attorney, Agent, or Firm—Young & Thompson

[57] **CLAIM**

The ornamental design for a wheel, as shown and described.

DESCRIPTION

FIG. 1 is a front and side perspective of a wheel showing my new design;
FIG. 2 is a side perspective view thereof;
FIG. 3 is a rear and side perspective view thereof;
FIG. 4 is a front perspective view thereof, taken slightly from the side.

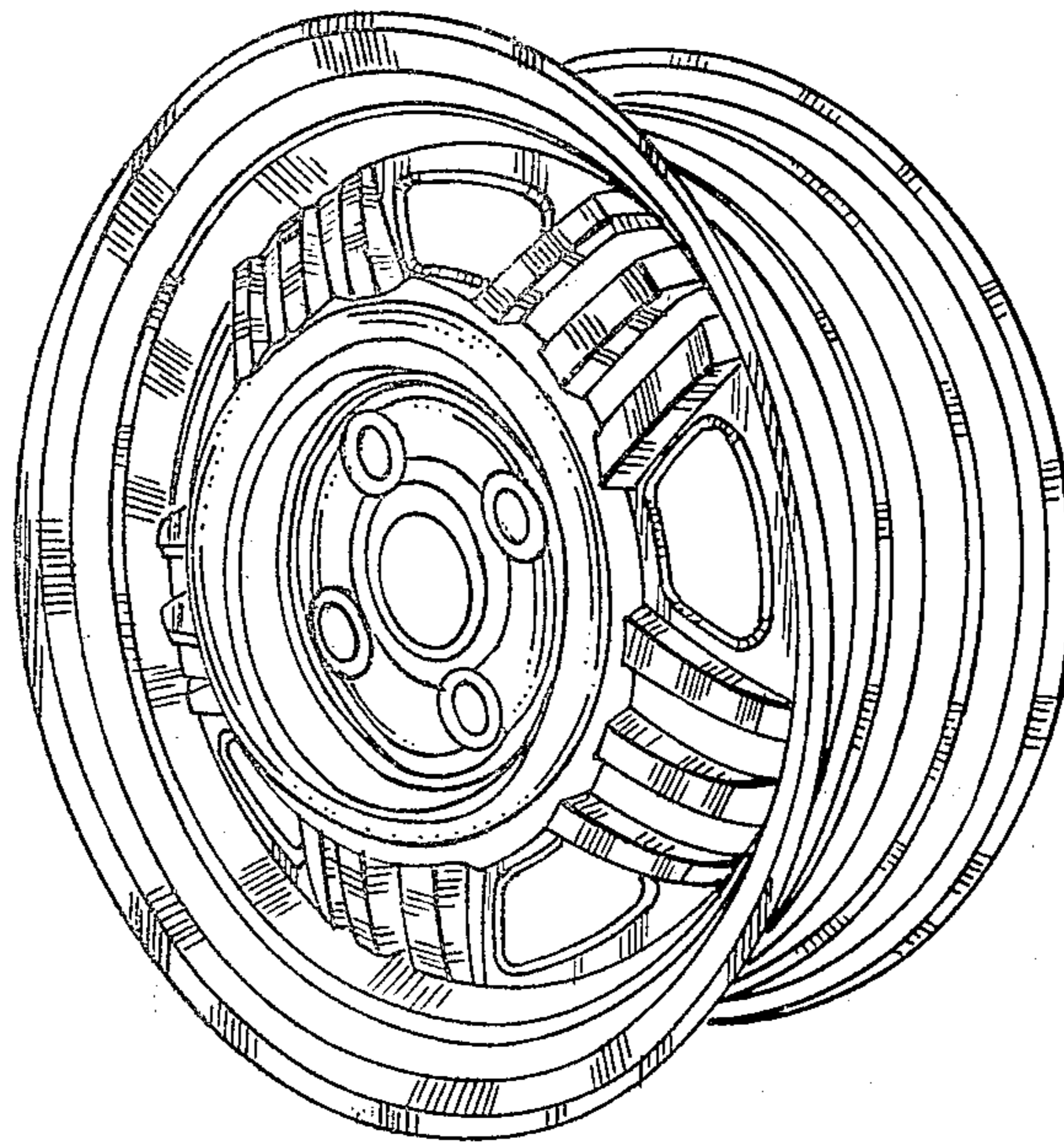

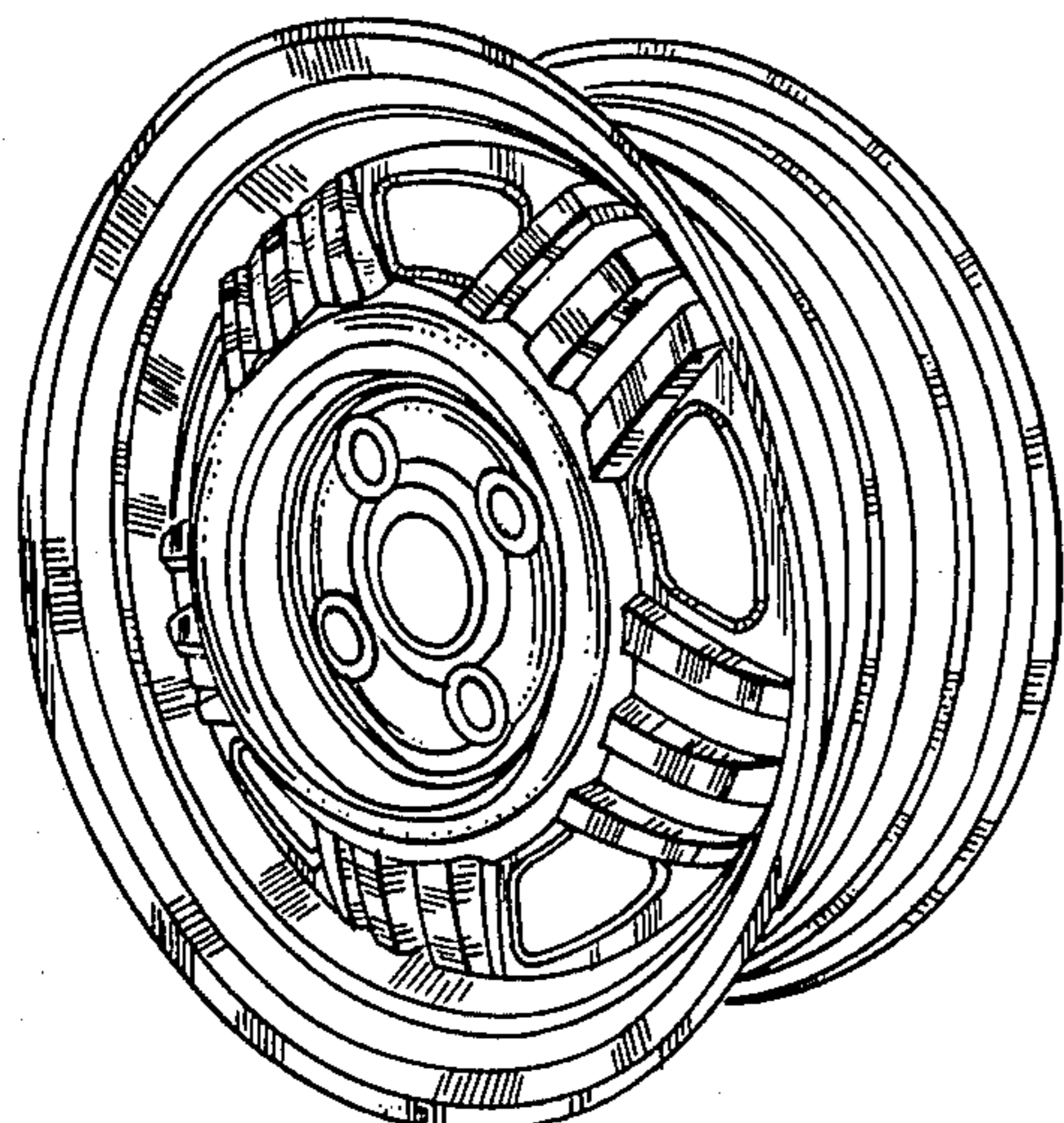

FIG. 1

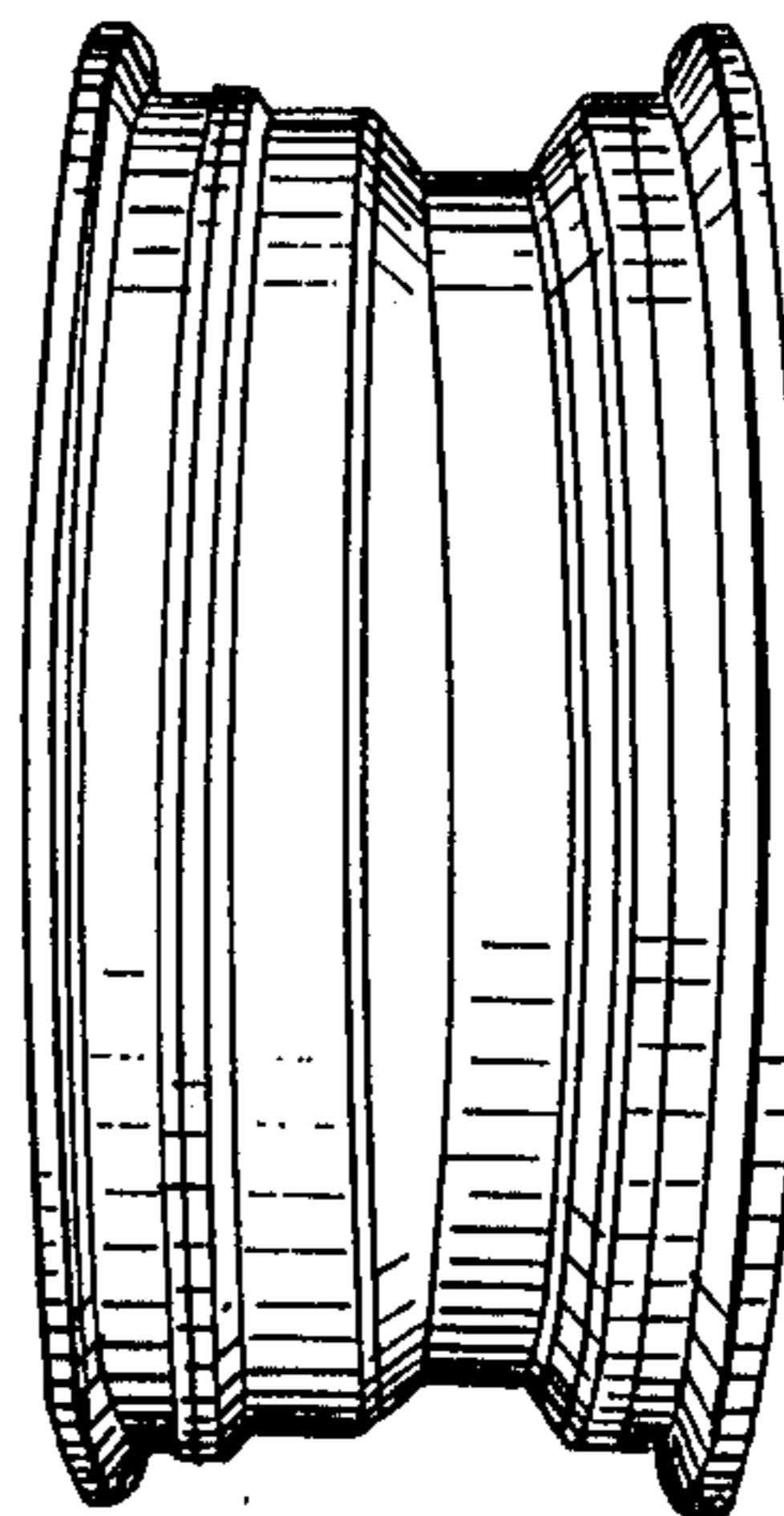

FIG. 2

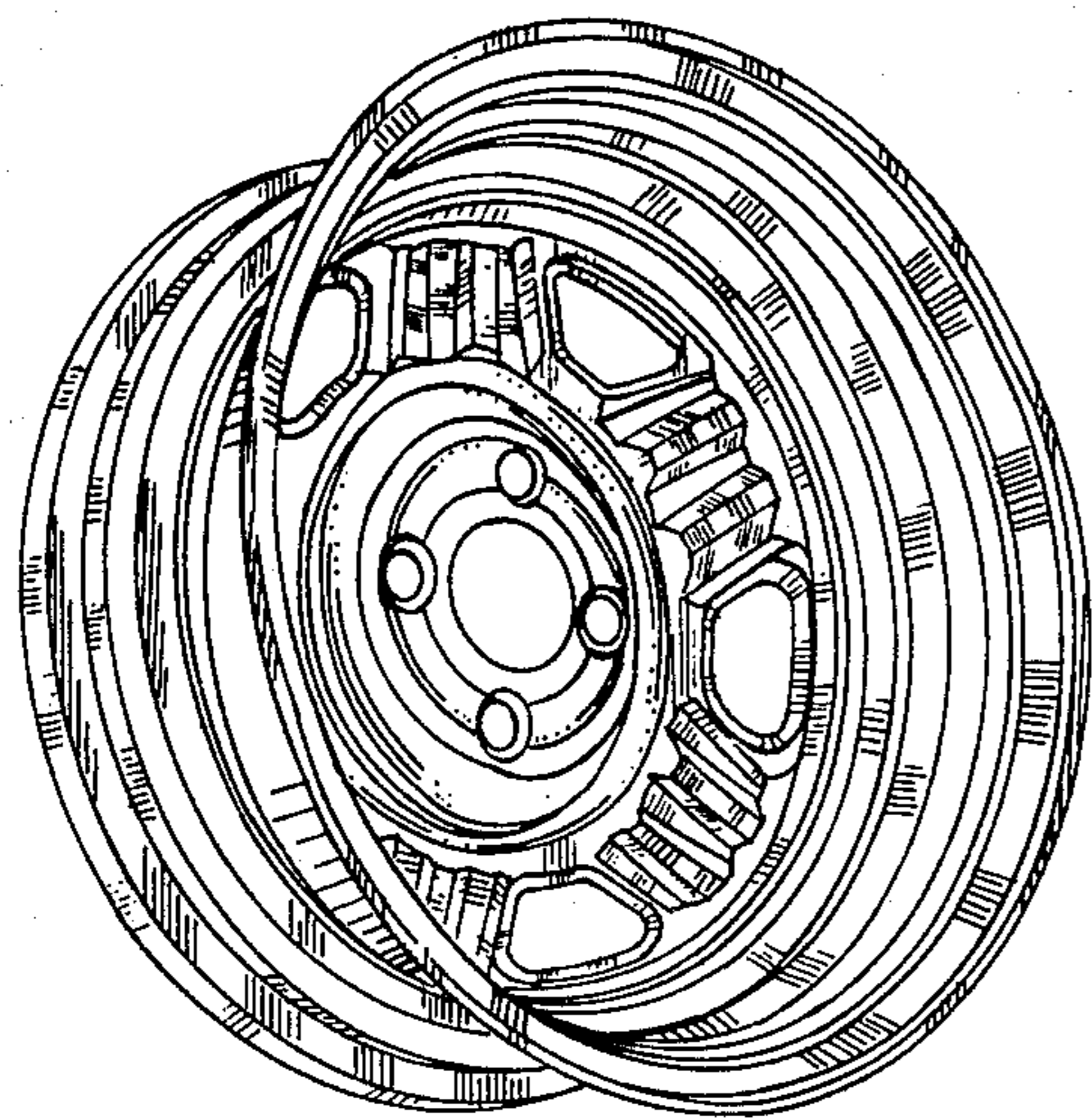

FIG. 3

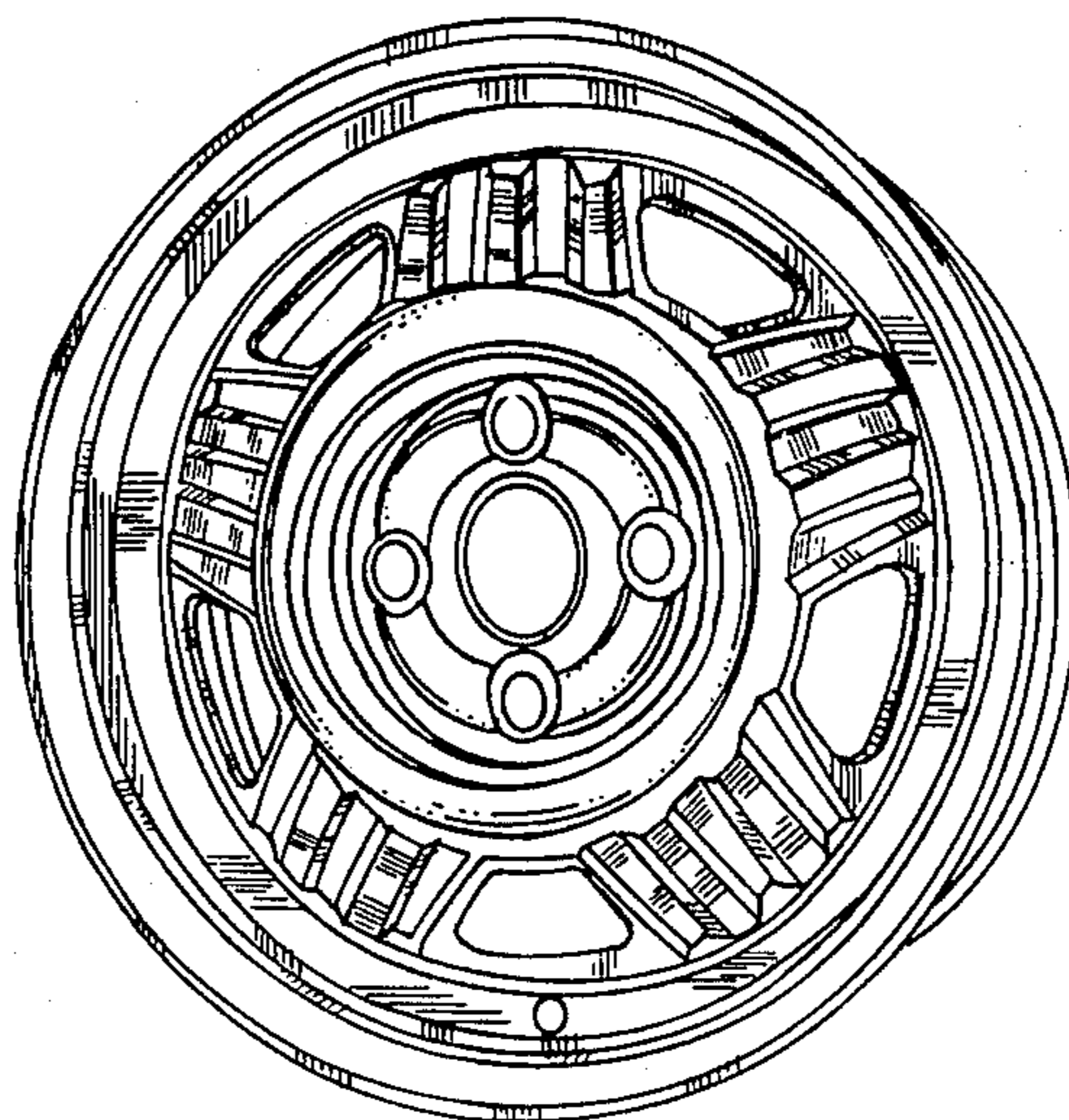

FIG. 4