

[54] **HOOK FASTENER FOR THE WAIST BANDS OF TROUSERS OR THE LIKE**

[75] **Inventor:** Yoshihiro Kanzaka, Nyuzen, Japan  
 [73] **Assignee:** Yoshida Kogyo K. K., Tokyo, Japan  
 [\*\*] **Term:** 14 Years  
 [21] **Appl. No.:** 250,287  
 [22] **Filed:** Apr. 2, 1981

[30] **Foreign Application Priority Data**

Mar. 7, 1980 [JP] Japan ..... 55-8892  
 [52] **U.S. Cl.** ..... D2/414; D2/405; D2/418  
 [58] **Field of Search** ..... D2/405, 414, 418; 24/225, 226, 227, 201 HE, 201 HH

[56] **References Cited**

**U.S. PATENT DOCUMENTS**

607,060	7/1898	Lord	.....	24/227
2,572,126	10/1951	Falone et al.	.....	24/227
2,886,873	5/1959	Walker	.....	24/227
2,961,728	11/1960	Cohn	.....	24/227
3,283,382	11/1966	Wood et al.	.....	24/227

**FOREIGN PATENT DOCUMENTS**

80346	12/1955	Denmark	.....	24/227
-------	---------	---------	-------	--------

52-447000 1/1977 Japan ..... D2/405 X

*Primary Examiner*—Bruce W. Dunkins  
*Assistant Examiner*—Carmen H. Vales  
*Attorney, Agent, or Firm*—Hill, Van Santen, Steadman & Simpson

[57] **CLAIM**

The ornamental design for a hook fastener for the waist bands of trousers or the like, substantially as shown and described.

**DESCRIPTION**

FIG. 1 is a front elevational view of a hook fastener for the waist band of trousers or the like showing my new design;  
 FIG. 2 is a rear elevational view thereof;  
 FIG. 3 is a top plan view thereof; the showing of a portion of garment in broken lines is for illustrative purposes only;  
 FIG. 4 is a right side elevational view of the hook fastener;  
 FIG. 5 is a right side elevational view of the eye;  
 FIG. 6 is a left side elevational view of the hook fastener;  
 FIG. 7 is a left side elevational view of the eye; and  
 FIG. 8 is a top plan view of the hook fastening for the waist bands of trousers or the like in operative condition; the broken lines are for illustrative purposes only.

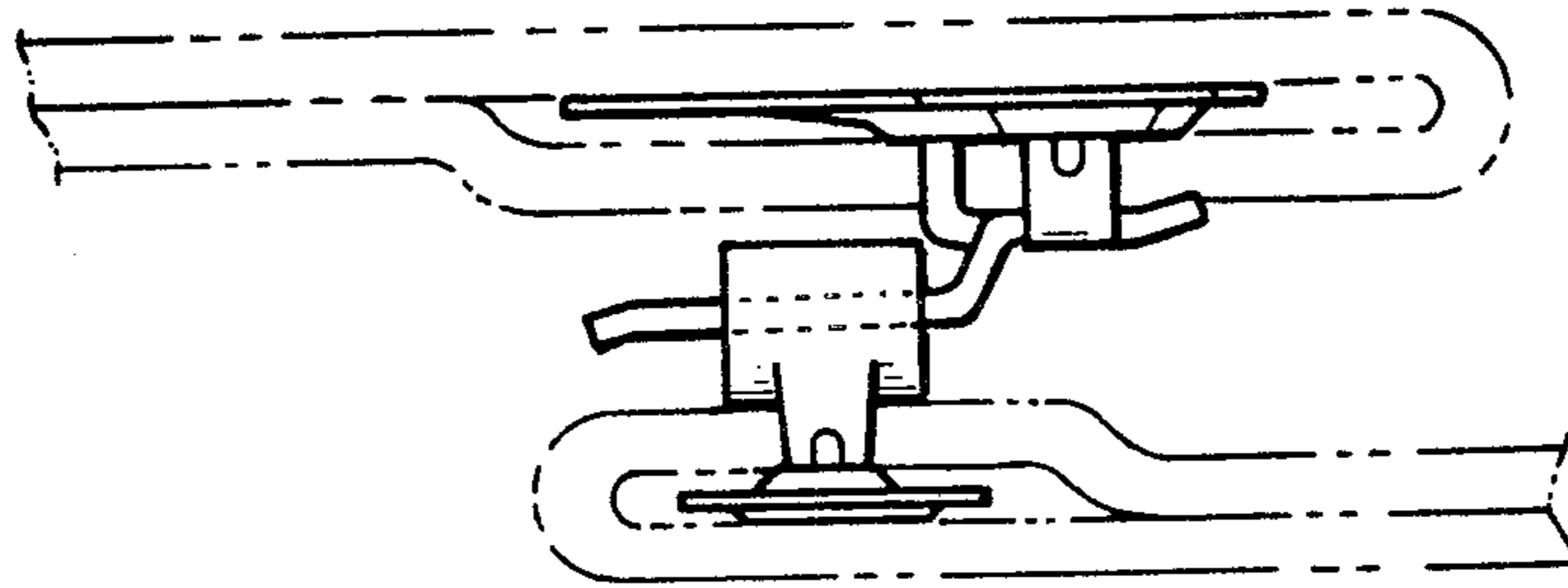
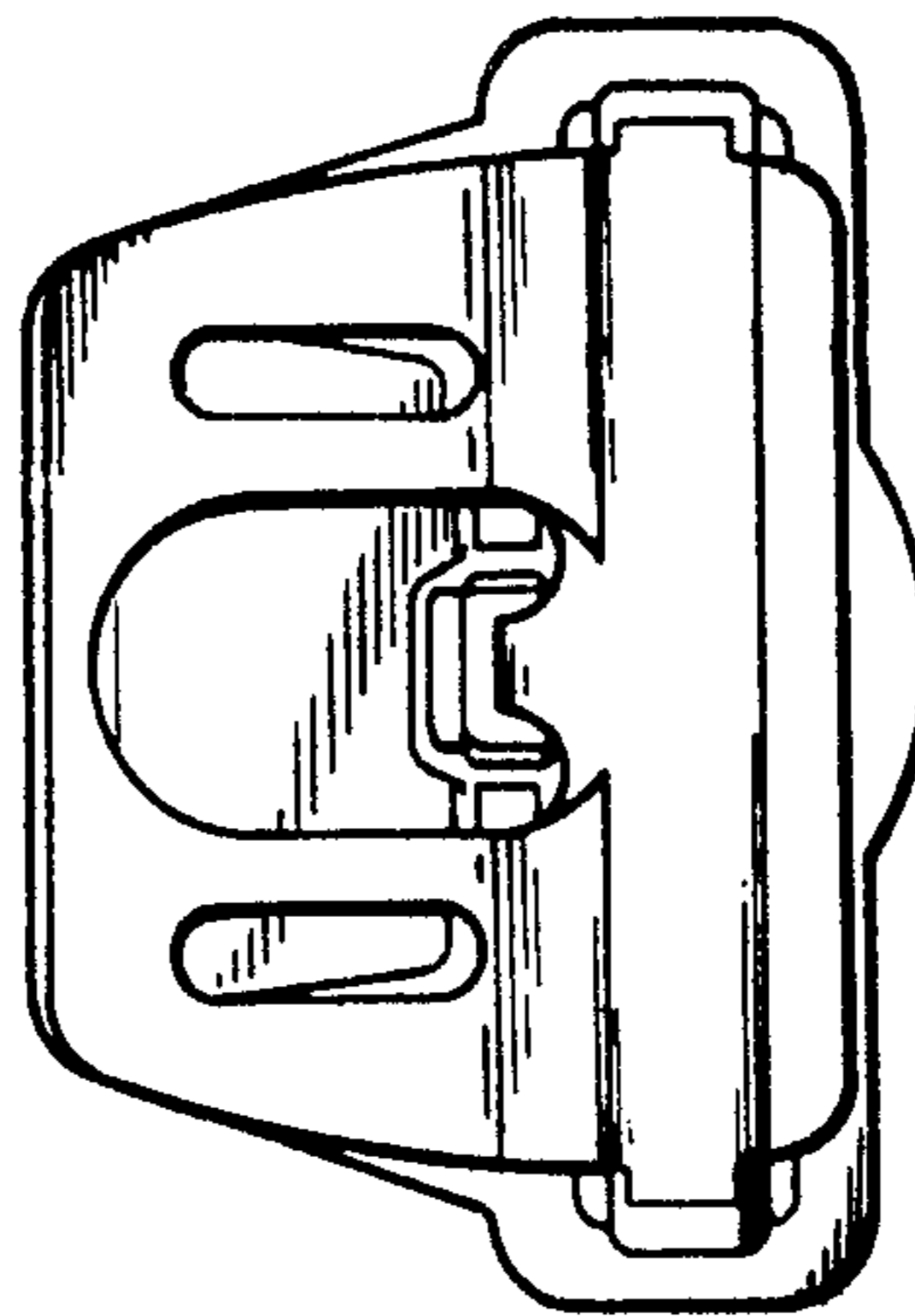
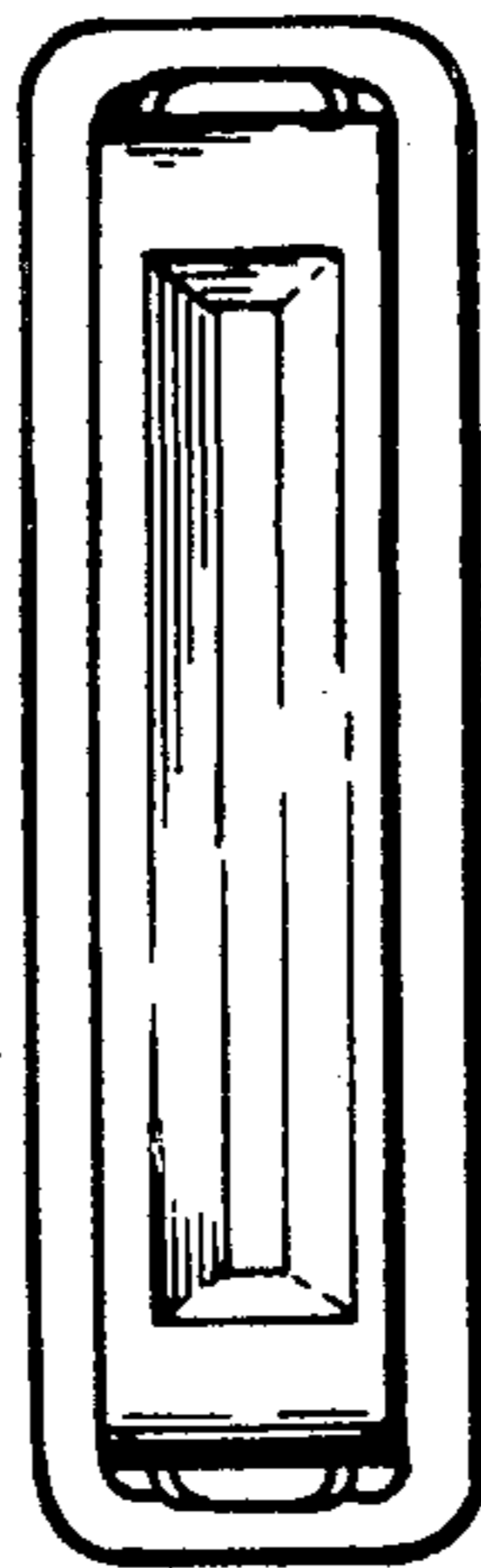

FIG. 1

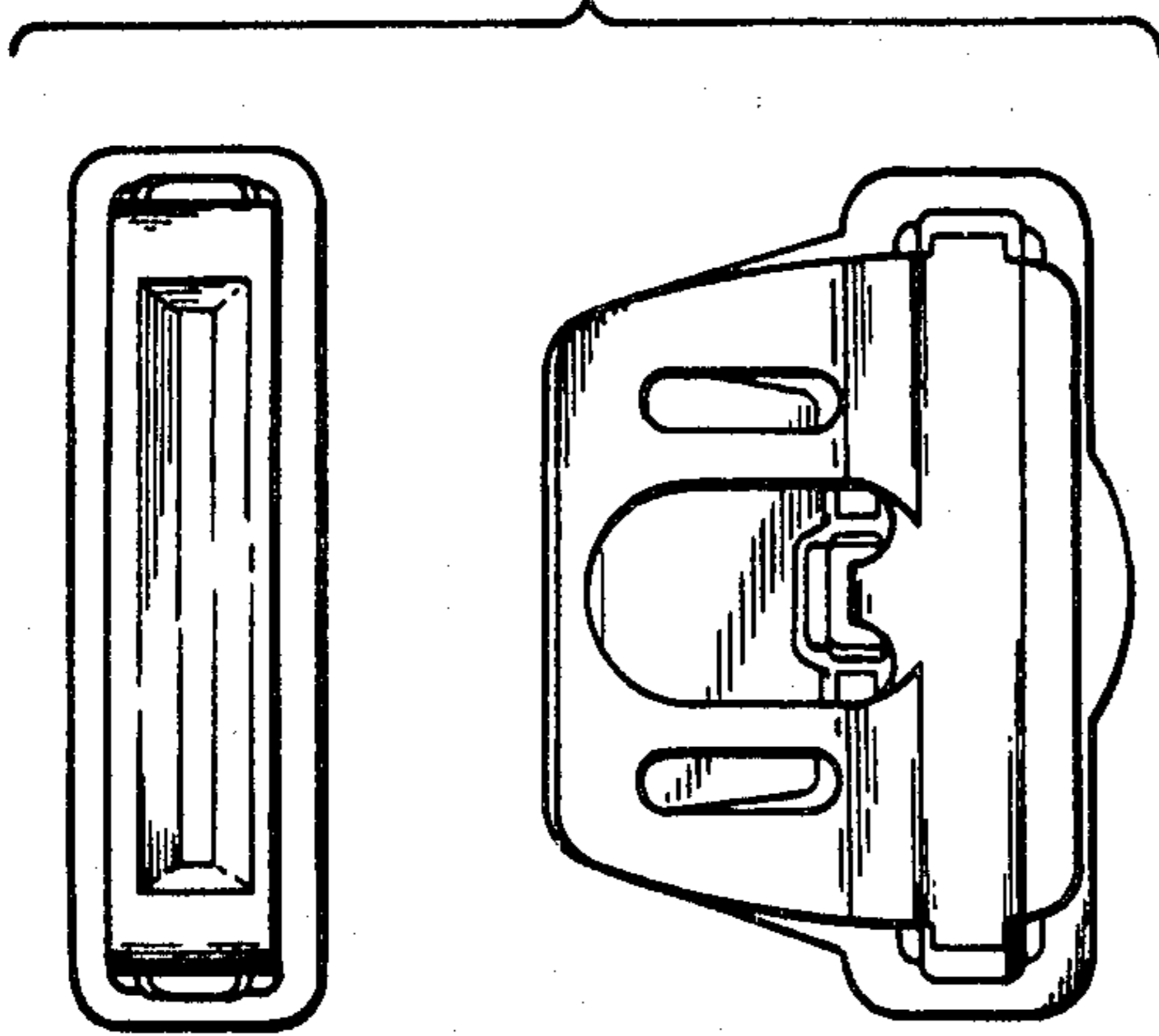

FIG. 2

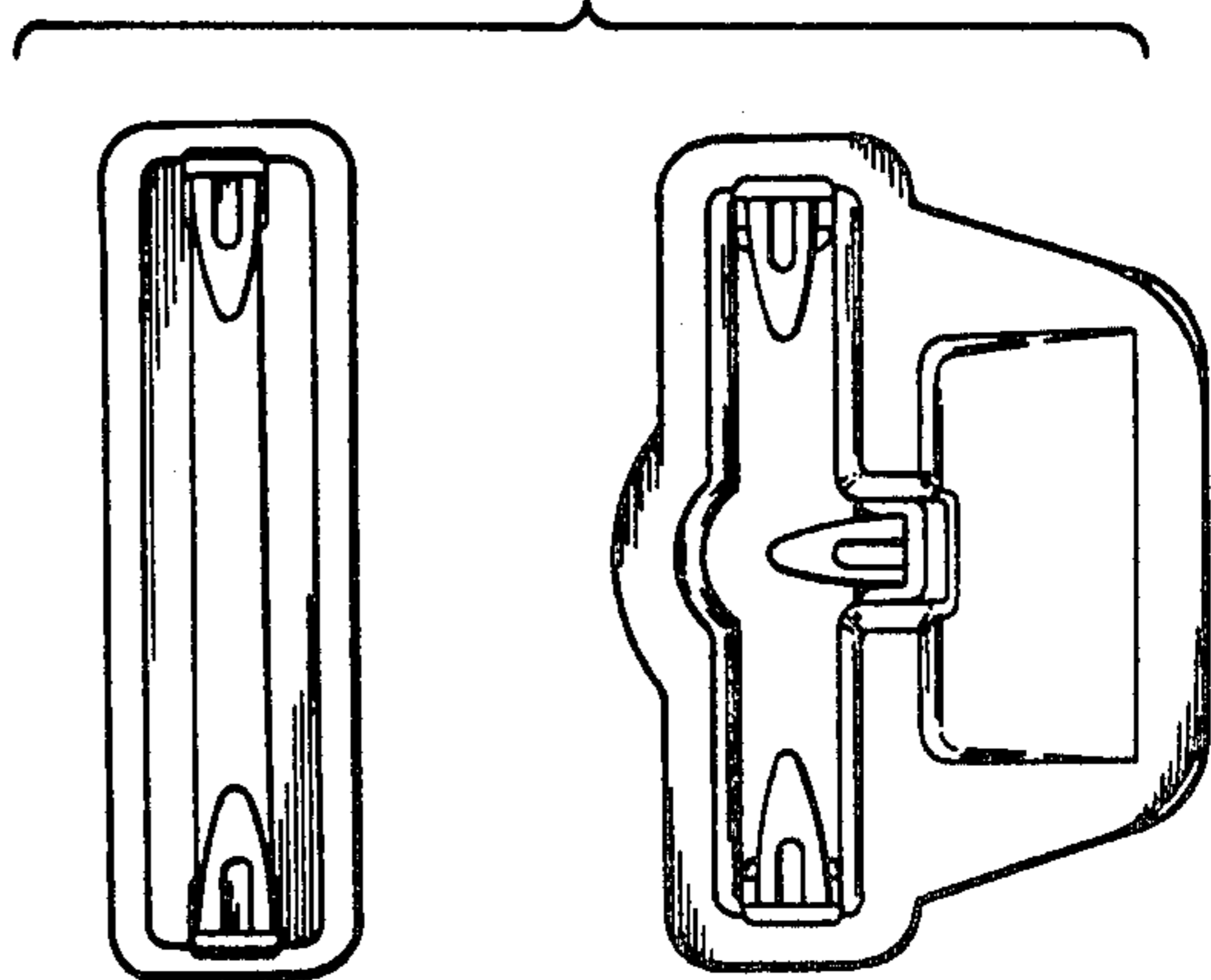

FIG. 8

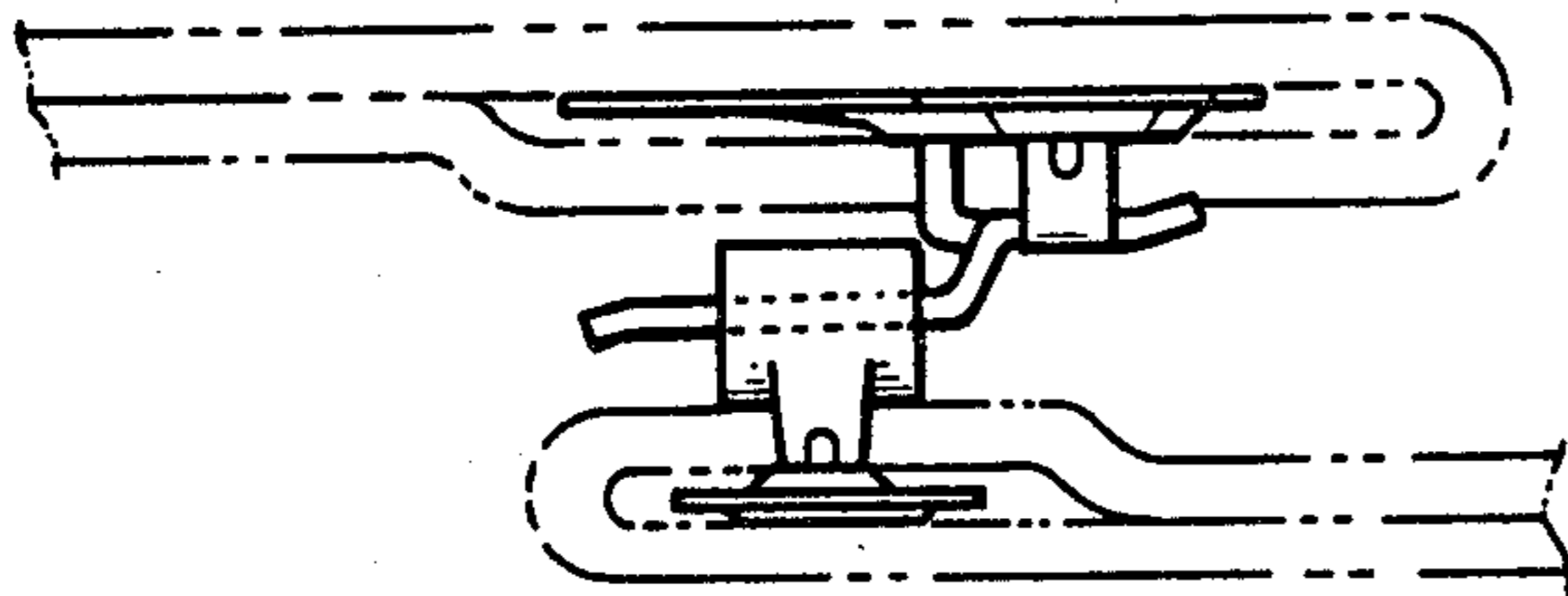

FIG. 3

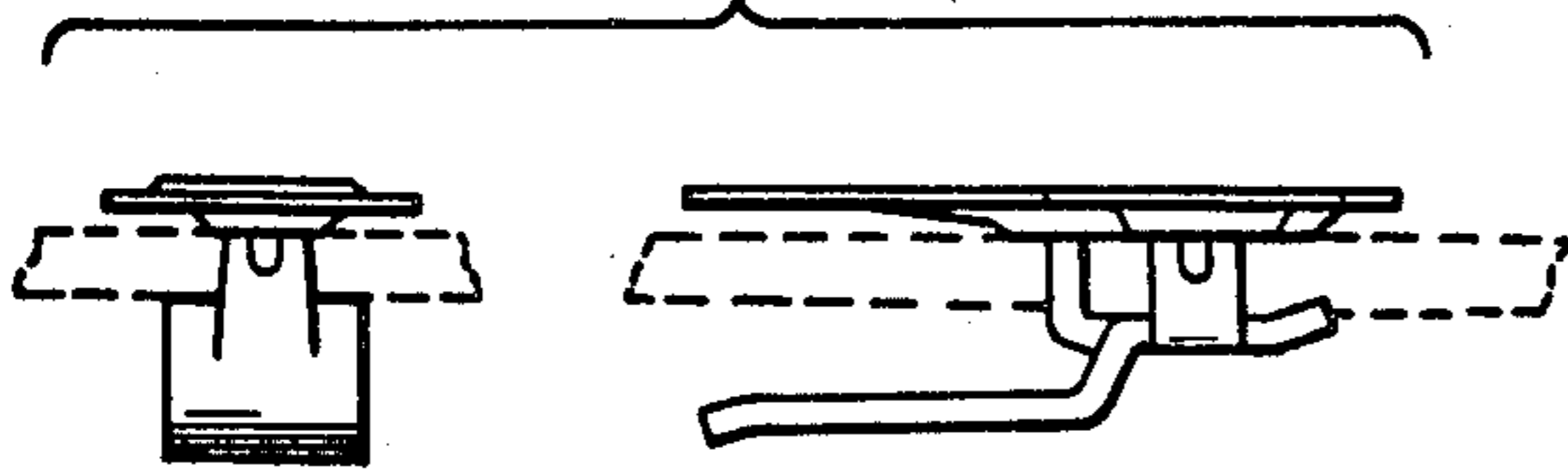

FIG. 4

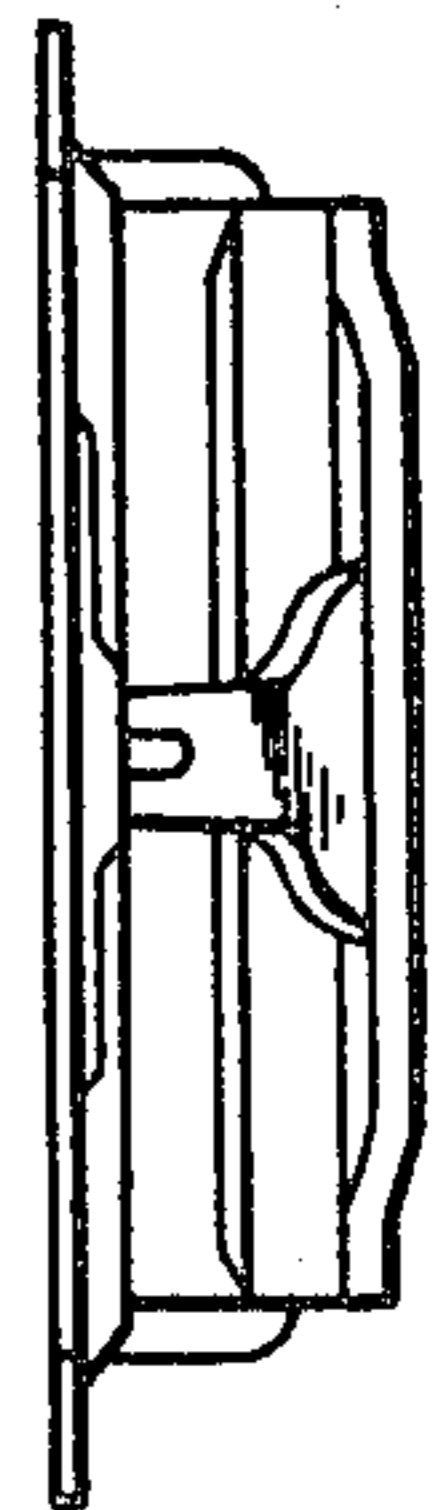

FIG. 5



FIG. 6



FIG. 7

