

[54] WHEEL FOR MOTORCAR

[75] Inventors: Bernhard Meyerspeer, Gries; Joachim Storz, Zell am See, both of Austria

[73] Assignee: Honda Giken Kogyo Kabushiki Kaisha, Tokyo, Japan

[\*\*] Term: 14 Years

[21] Appl. No.: 418,824

[22] Filed: Sep. 16, 1982

[30] Foreign Application Priority Data

Mar. 20, 1982 [JP] Japan ..... 57/11236

[52] U.S. Cl. .... D12/206; D12/209

[58] Field of Search ..... D12/204, 206, 209, 211; 301/63 R, 64 R, 65, 64 SD, 66

[56] References Cited

U.S. PATENT DOCUMENTS

D. 259,342 5/1981 Envall et al. .... D12/209  
1,619,802 3/1927 Baker ..... D12/209

OTHER PUBLICATIONS

Road & Track, 1/80, p. 59, Wheel on Renault R-140 Car, bottom of page.

Road & Track, 1/80, p. 87, Wheel on Ford Mustang, bottom of page.

Primary Examiner—James M. Gandy  
Attorney, Agent, or Firm—Armstrong, Nikaido, Marmelstein & Kubovcik

[57] CLAIM

The ornamental design for a wheel for motorcar, as shown and described.

DESCRIPTION

FIG. 1 is a front elevational view of a wheel for motorcar, showing our new design;  
FIG. 2 is a rear elevational view thereof;  
FIG. 3 is a top plan view thereof;  
FIG. 4 is a bottom plan view thereof;  
FIG. 5 is a right side elevational view thereof; and  
FIG. 6 is a sectional view taken along the line VI—VI in FIG. 1.

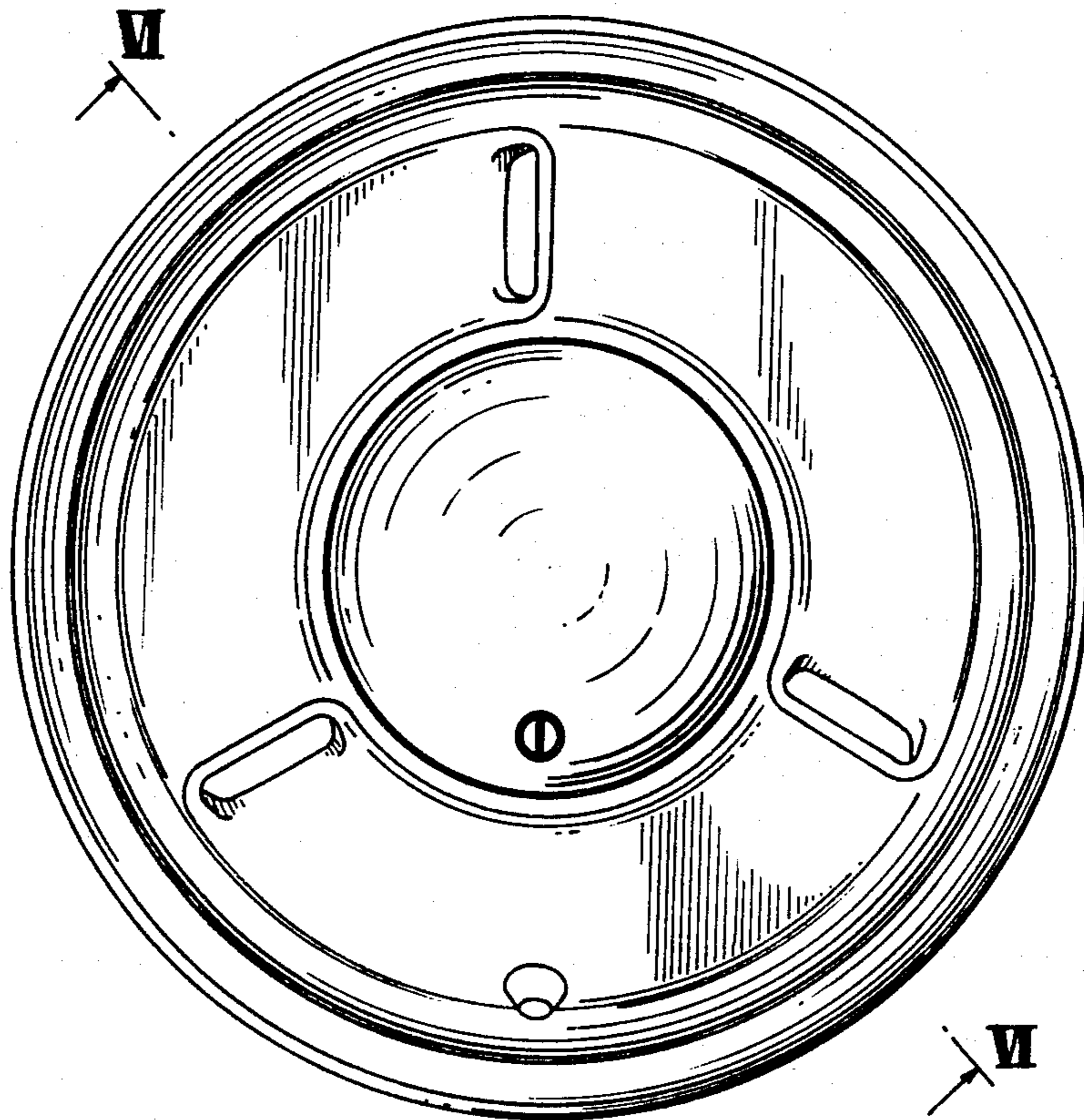

FIG. 1

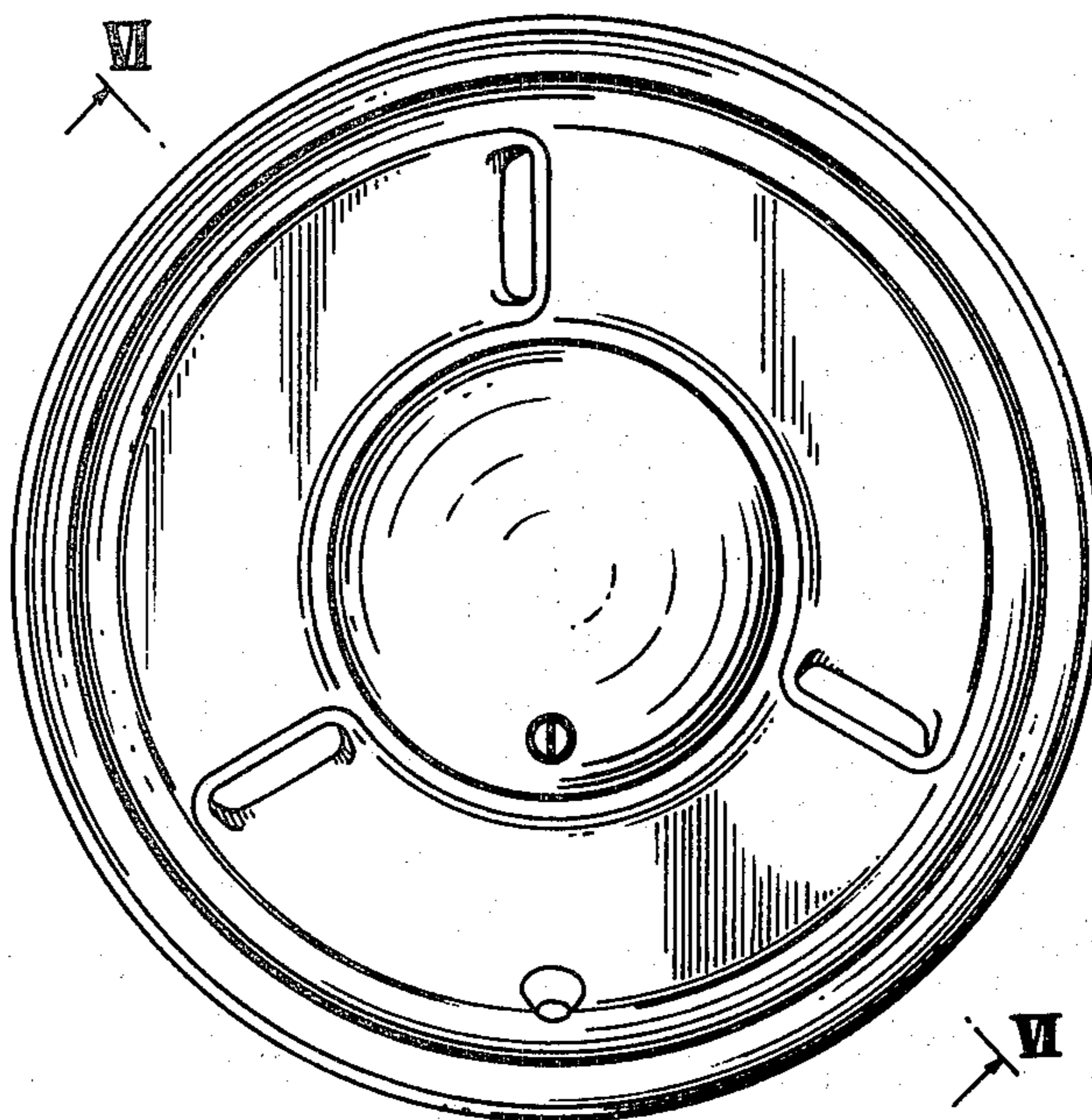

FIG. 2

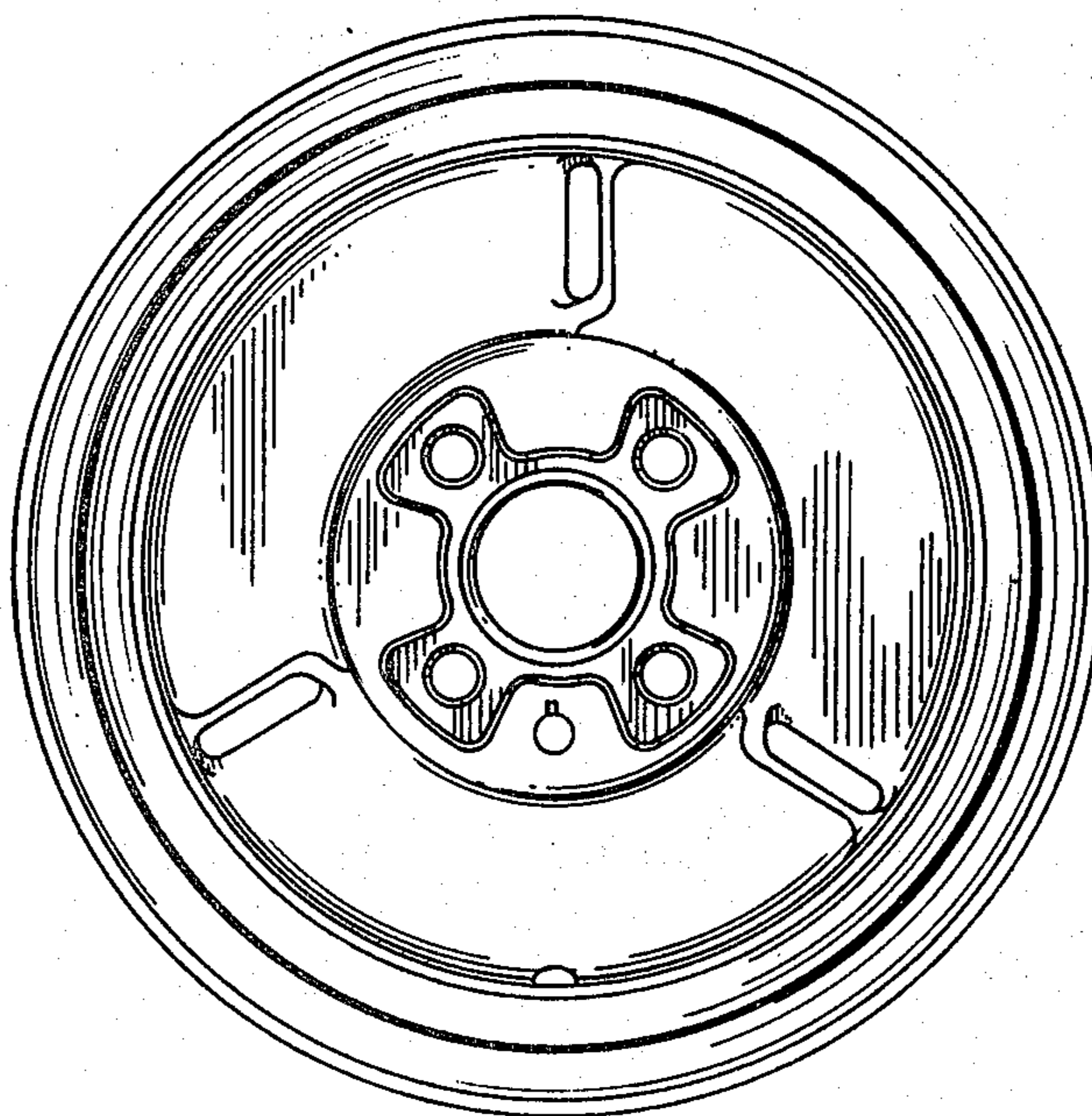

FIG.3

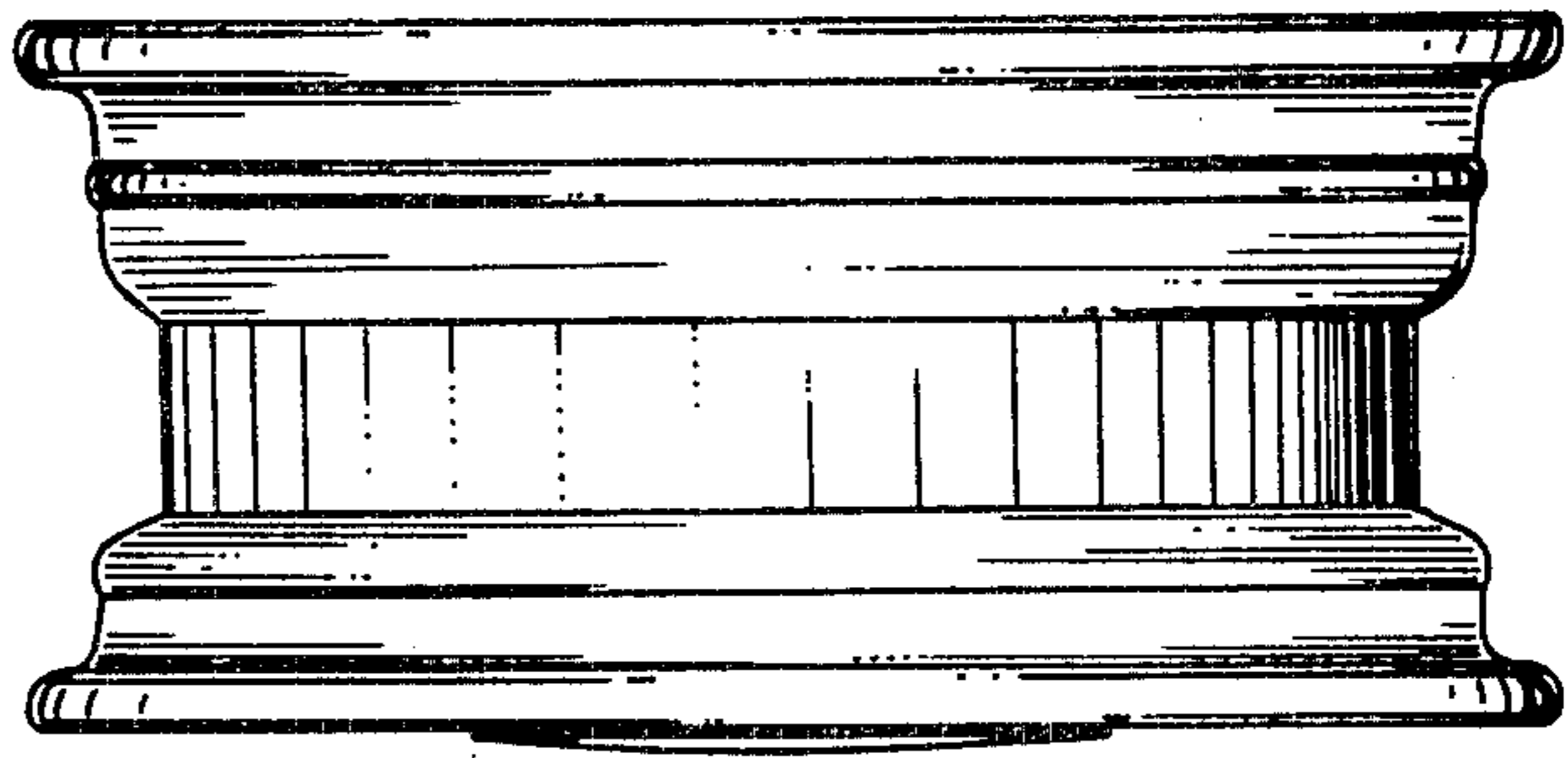

FIG.4

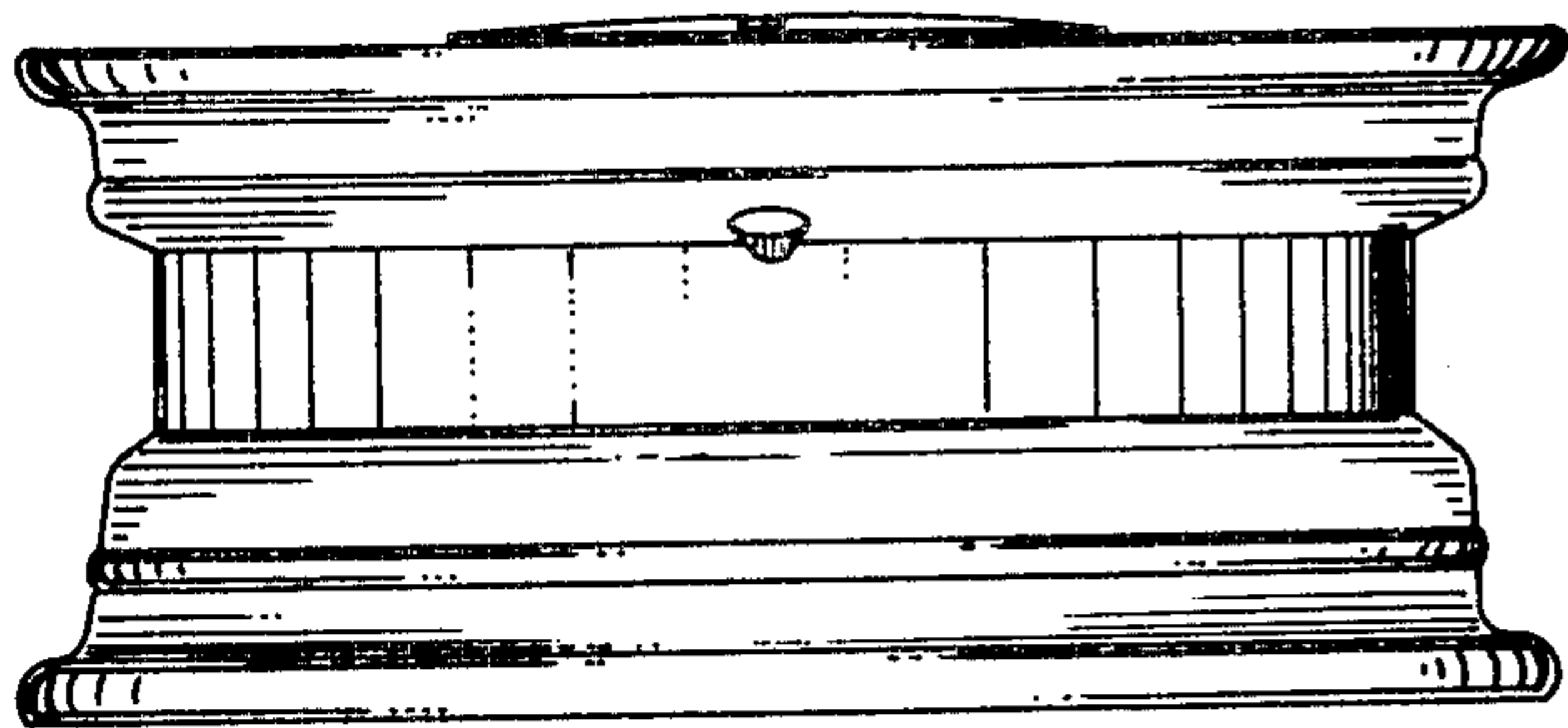

FIG.5

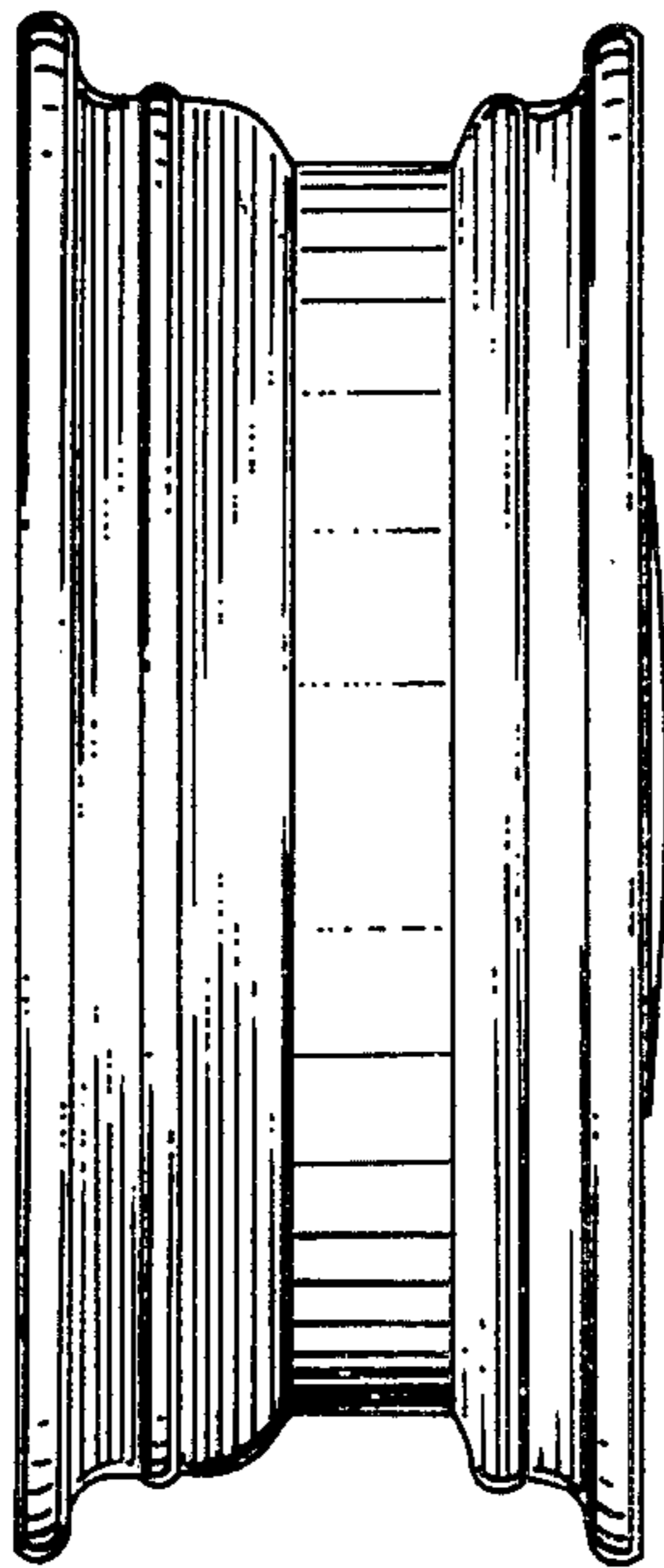

FIG.6

