

[54] BICYCLE

[75] Inventors: Robert A. Martin; Robert A. Rowe, both of Santa Barbara; Guthrie E. Martin, Redlands, all of Calif.

[73] Assignee: Martin, Rowe and Martin, Santa Barbara, Calif.

[**] Term: 14 Years

[21] Appl. No.: 446,730

[22] Filed: Dec. 3, 1982

[52] U.S. Cl. D12/111

[58] Field of Search D12/111; 280/261, 270, 280/281 R, 281 LP

[56] References Cited

U.S. PATENT DOCUMENTS

- D. 202,968 11/1965 Carey et al. D12/111
- D. 236,803 9/1975 Ennis D12/111

OTHER PUBLICATIONS

American Bicyclist & Motorcyclist, 7/58, p. 18, "Lazy-bones" Bicycle, top left side of page.

Primary Examiner—James M. Gandy
Attorney, Agent, or Firm—Christie, Parker and Hale

[57] CLAIM

The ornamental design for a bicycle, substantially as shown and described.

DESCRIPTION

FIG. 1 is a side elevational view of a bicycle showing our new design;
 FIG. 2 is a top plan view thereof;
 FIG. 3 is a bottom plan view thereof;
 FIG. 4 is a front elevational view thereof;
 FIG. 5 is a rear elevational view thereof; and
 FIG. 6 is a side elevational view thereof opposite to that shown in FIG. 1.

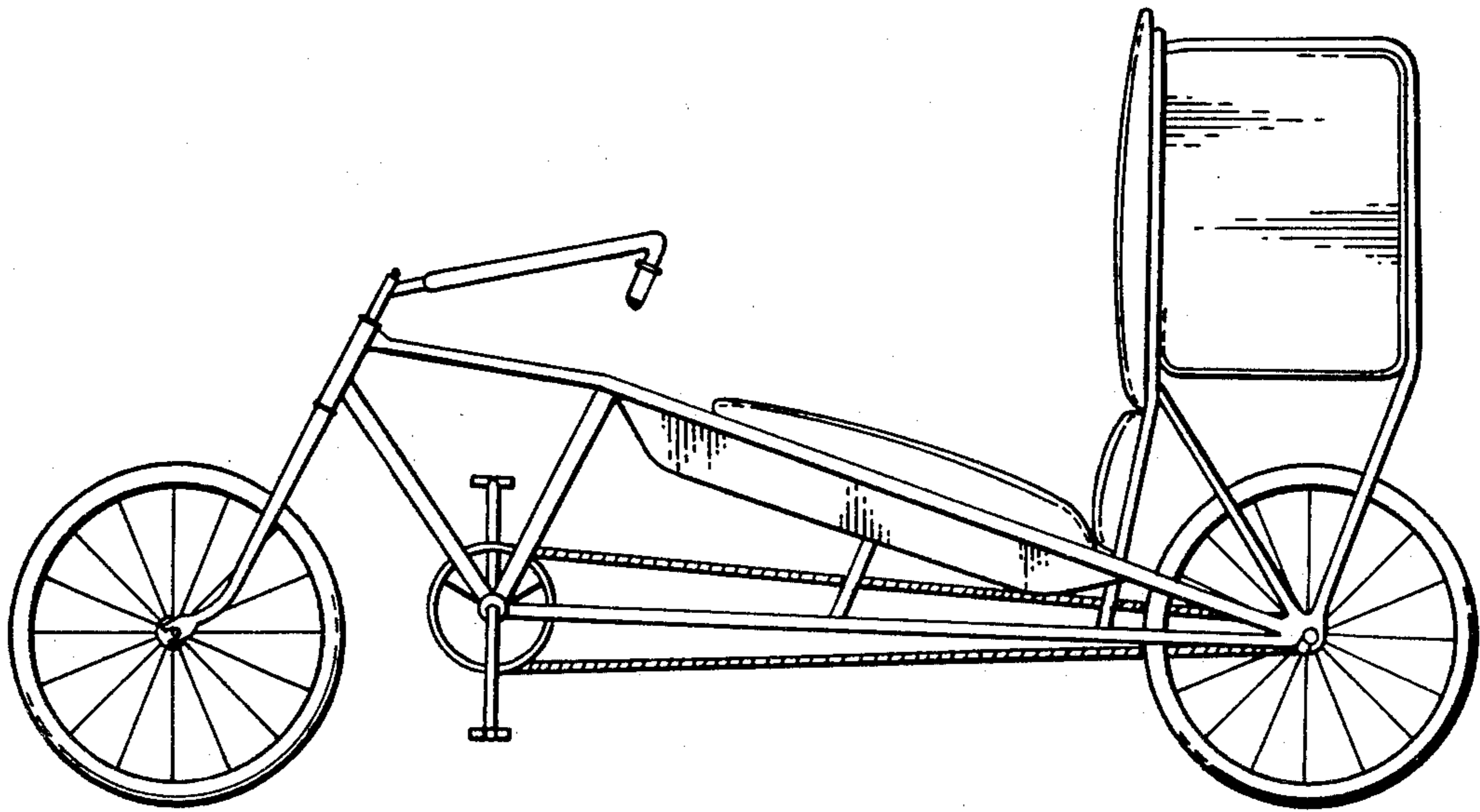

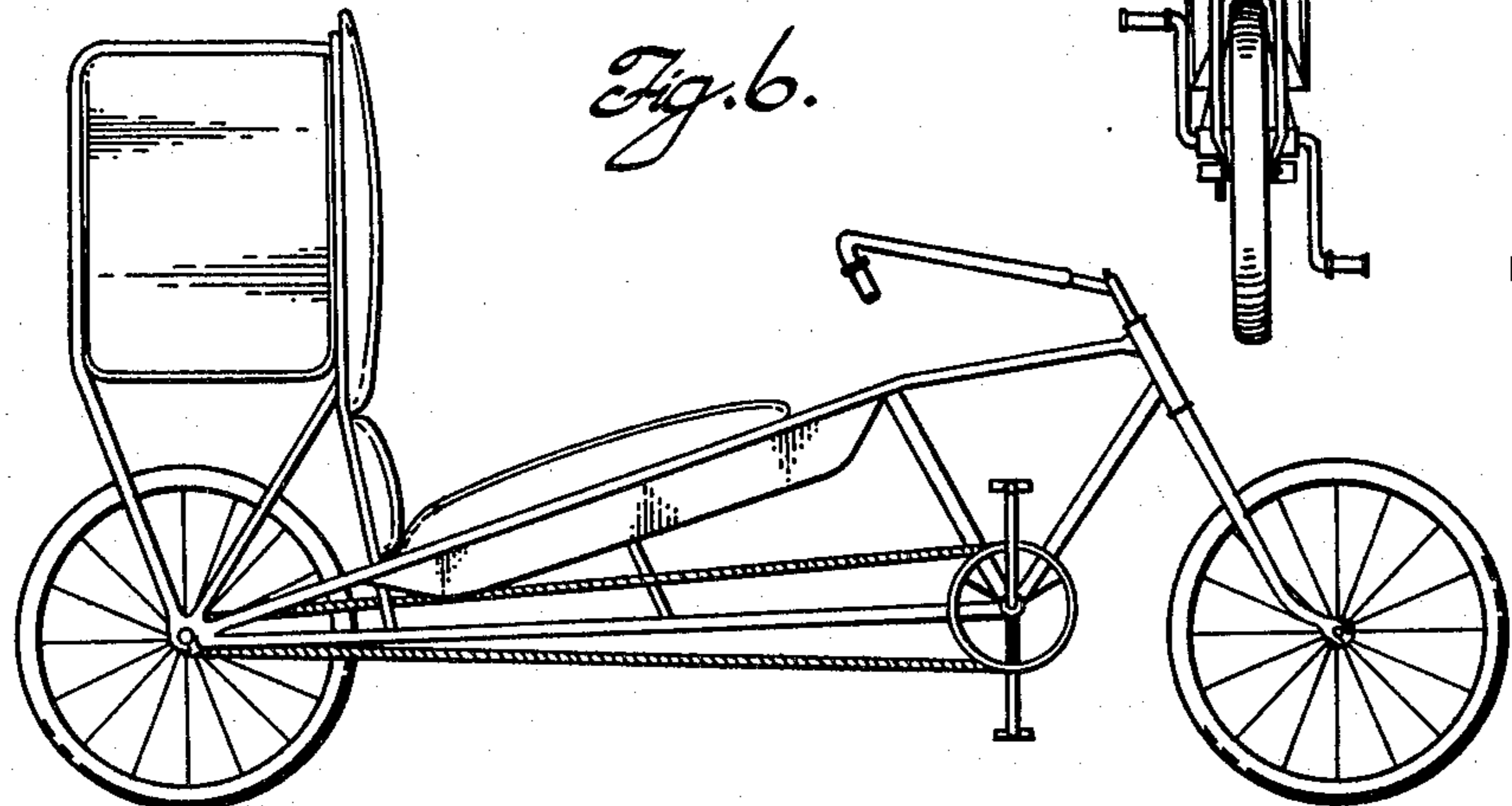
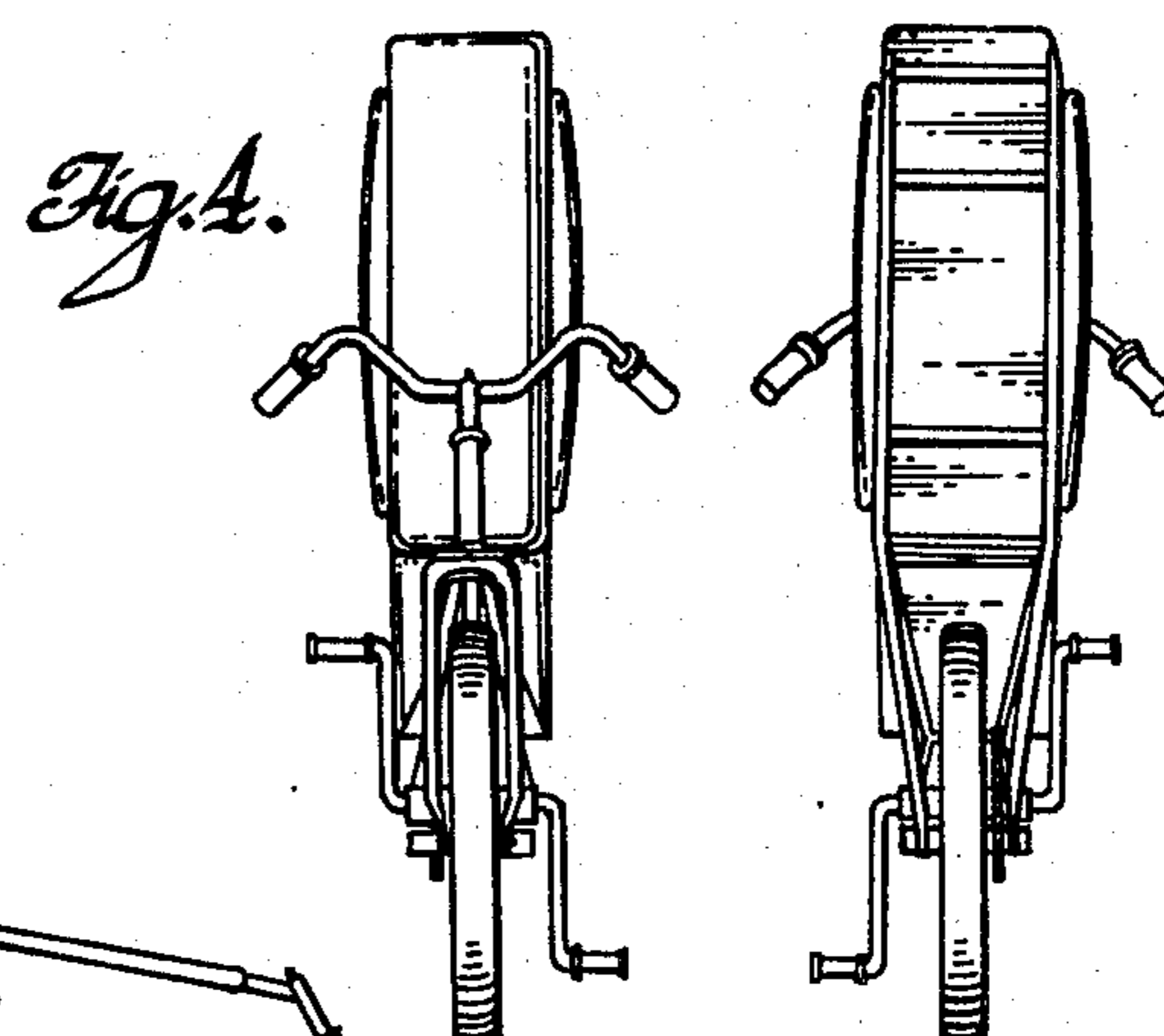
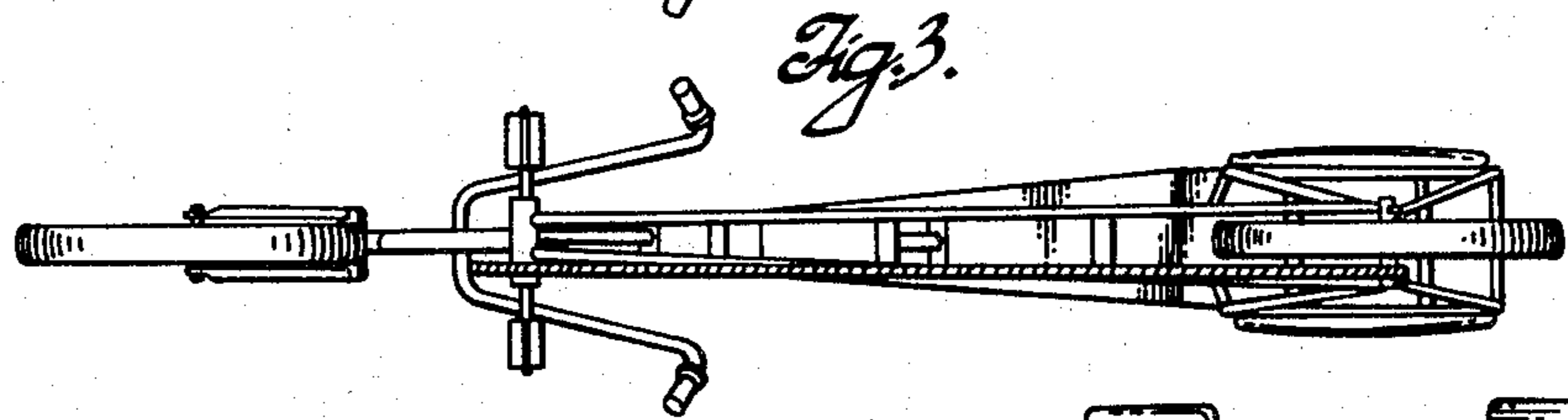
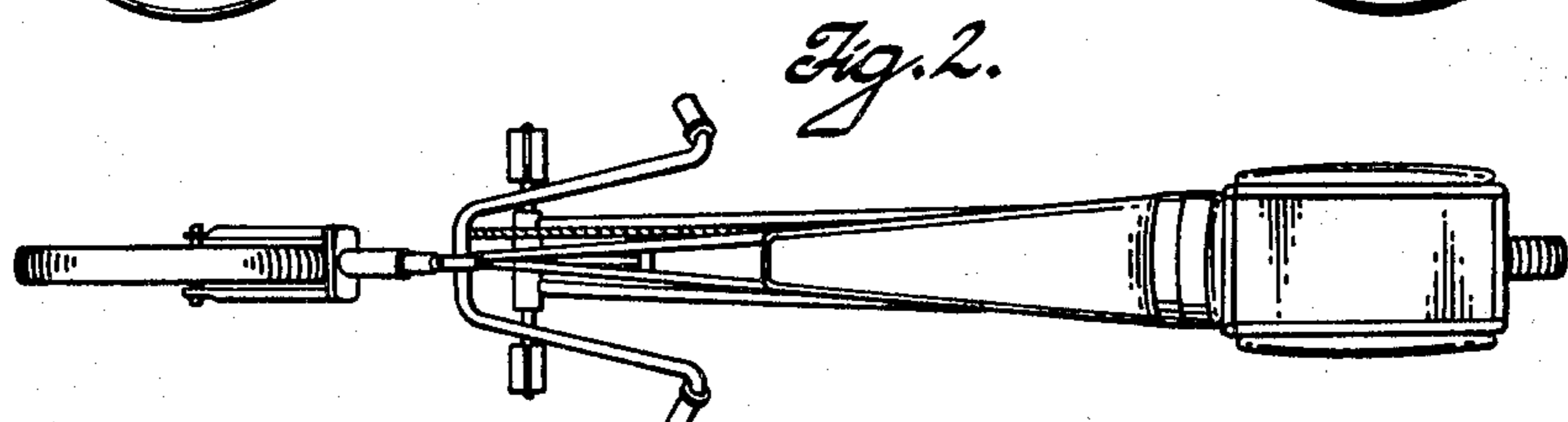
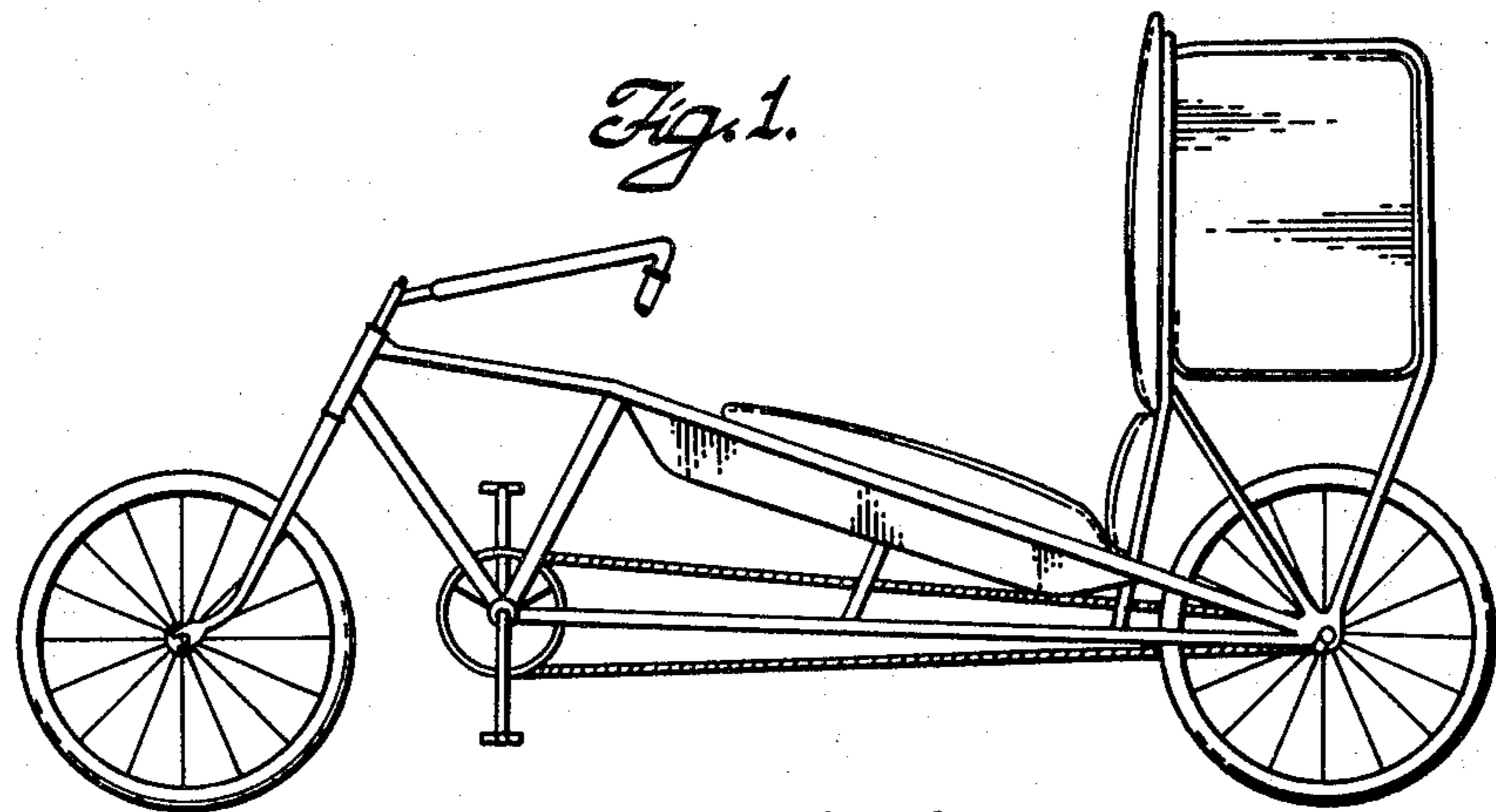

Fig. 6.