

[54] COMBINED ARMORED VEHICLE GUN TURRET AND CONTROL PIT

Primary Examiner—James M. Gandy
Attorney, Agent, or Firm—Lalos, Leeds, Keegan, Lett & Marsh

[76] Inventor: James C. LeBlanc, 38261 Long St., Mt. Clemens, Mich. 48045

[57] CLAIM

[**] Term: 14 Years

The ornamental design for a combined armored vehicle gun turret and control pit, as shown and described.

[21] Appl. No.: 256,656

DESCRIPTION

[22] Filed: Apr. 22, 1981

[52] U.S. Cl. D12/12

[58] Field of Search D12/12; 89/36 H, 36 K, 89/36 L

FIG. 1 is a left-side elevational view of a combined armored vehicle gun turret and control pit illustrating my new design;

FIG. 2 is a top plan view thereof;

FIG. 3 is a right-side elevational view thereof;

FIG. 4 is a front elevational view thereof; and,

FIG. 5 is a rear elevational view thereof.

The broken lines in the drawing are for illustrative purposes only.

[56] References Cited

U.S. PATENT DOCUMENTS

- D. 244,999 7/1977 Longeau D12/12
- D. 264,322 5/1982 LeBlanc D12/12

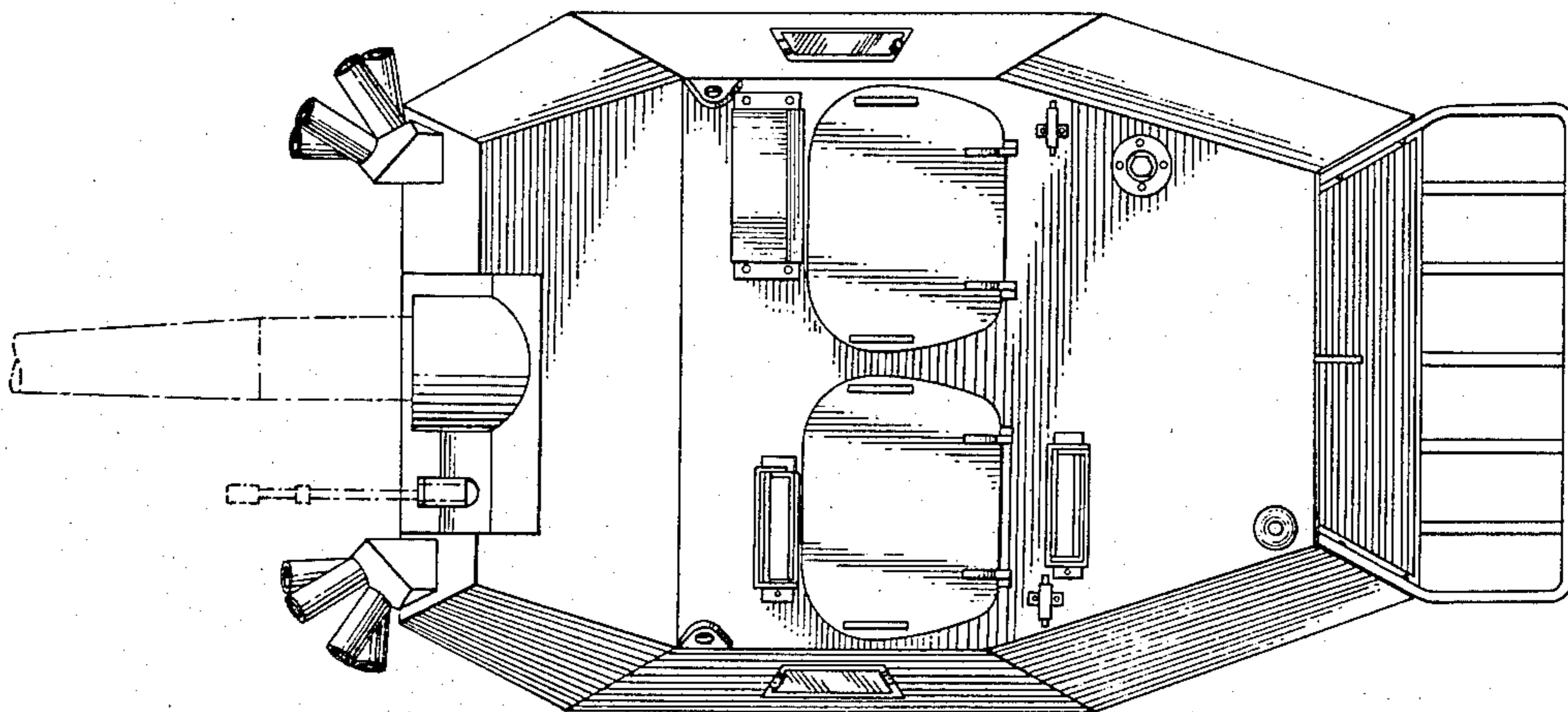
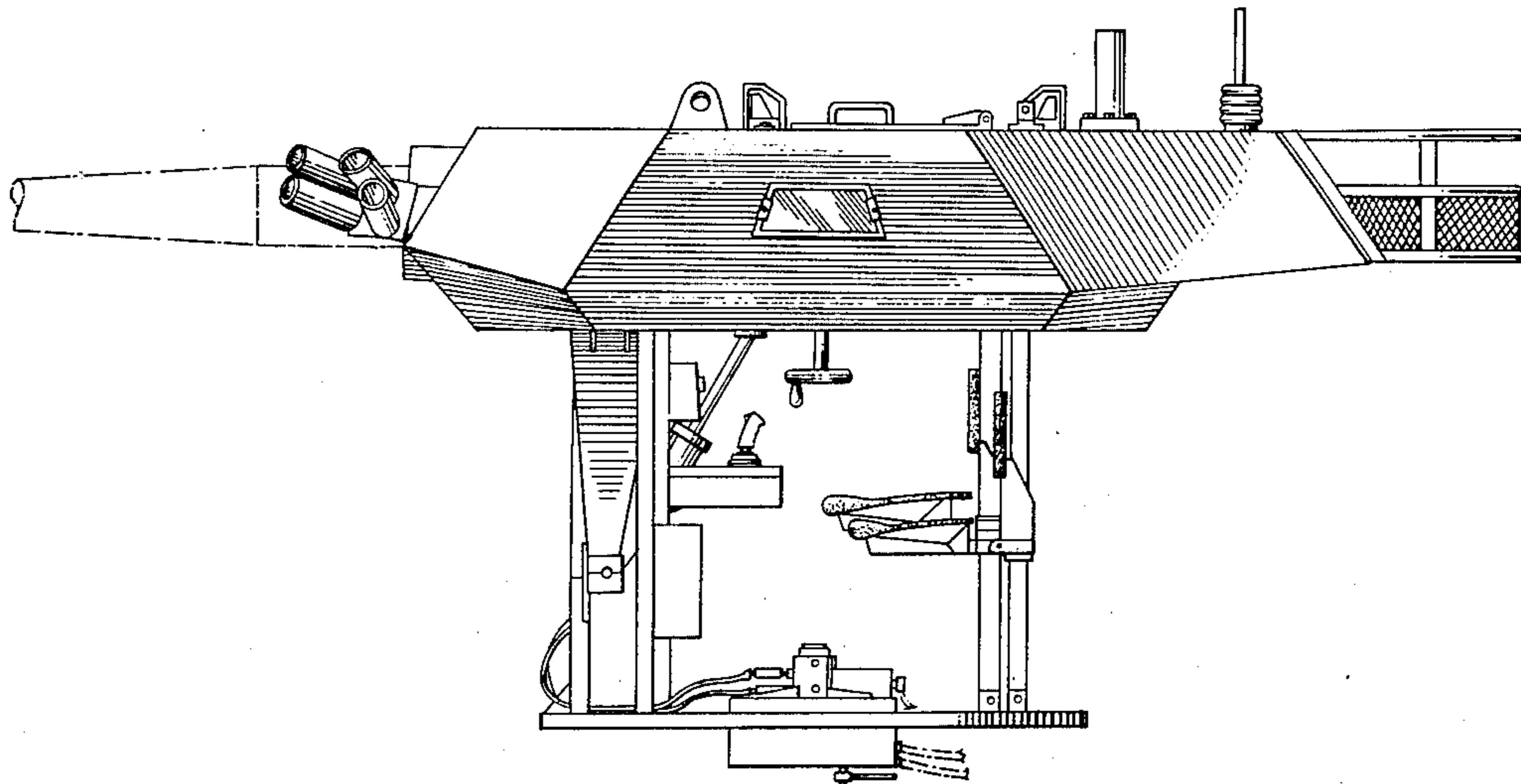

FIG. 1.

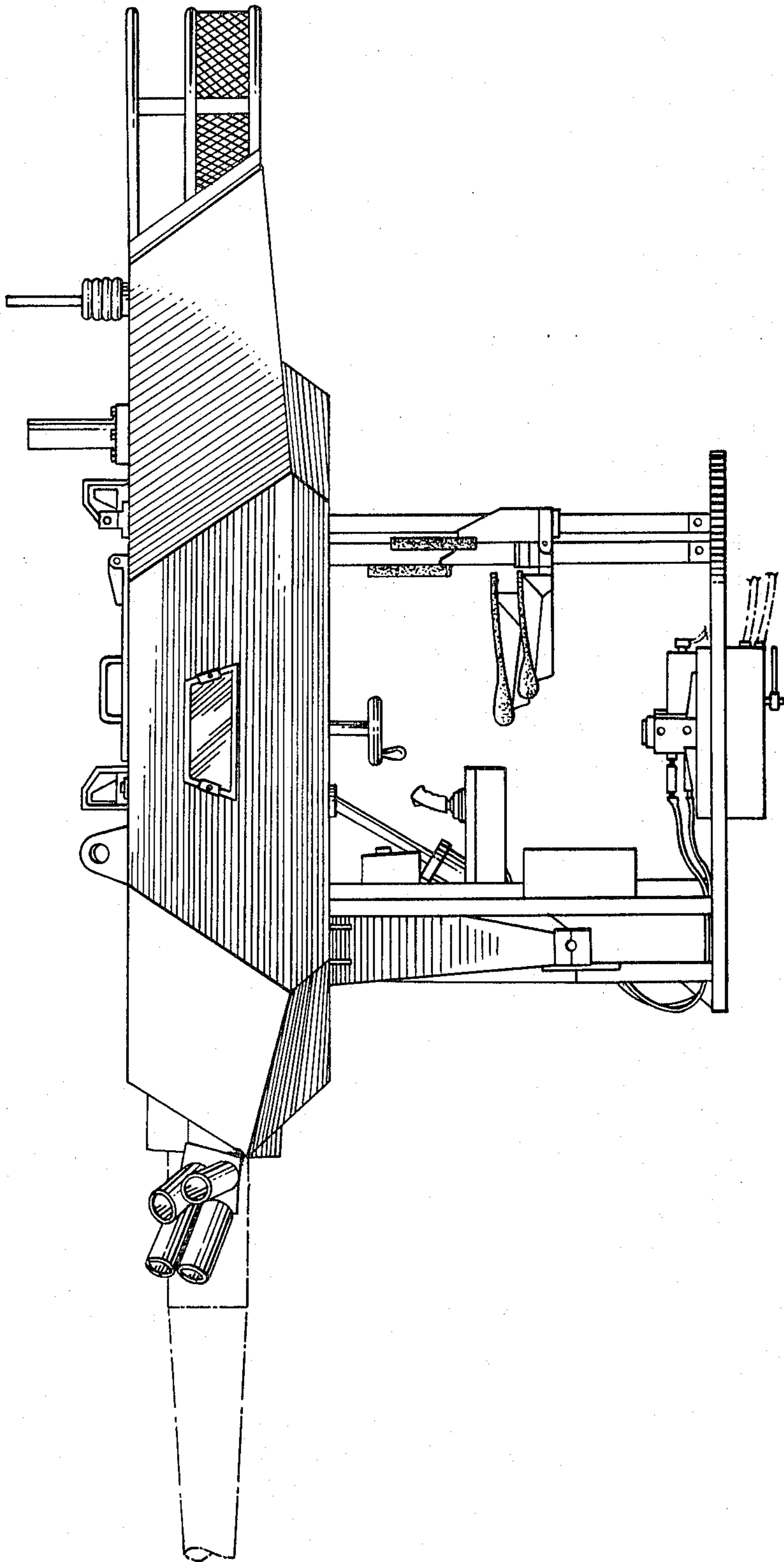

FIG. 2.

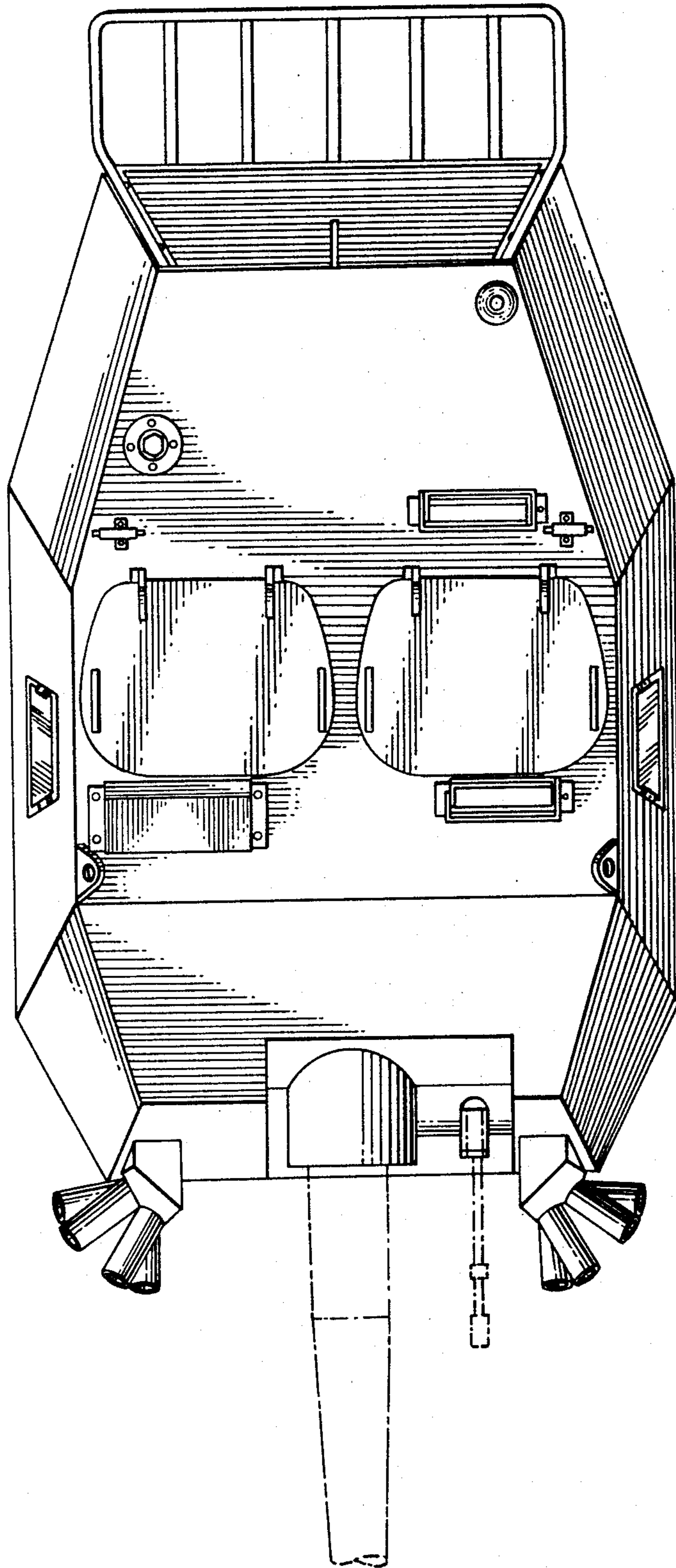

FIG. 3.

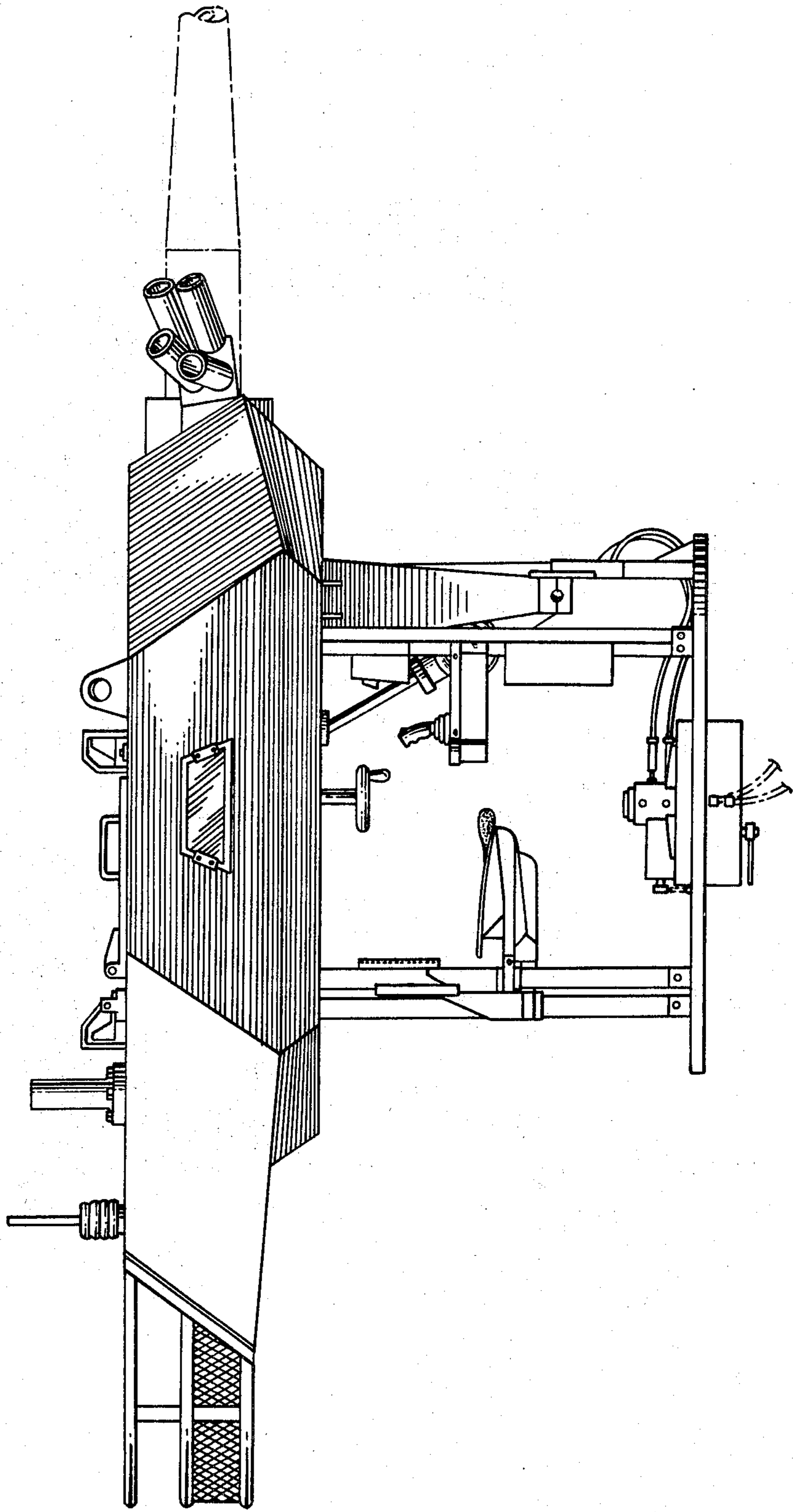

FIG. 5.

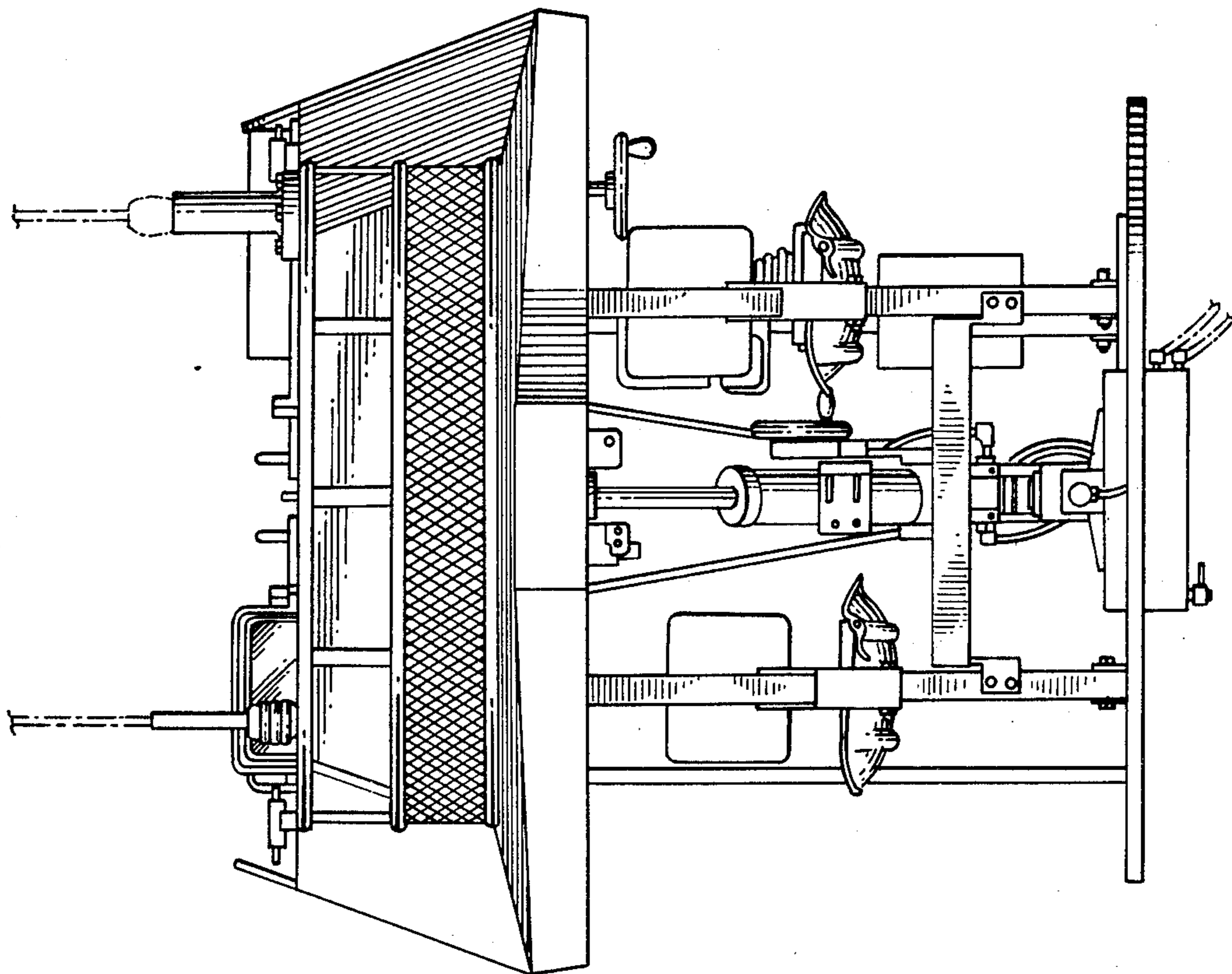

FIG. 4.

