

[54] MICROBIOLOGICAL TESTING SYRINGE

[75] Inventors: Howard M. Chandler, Kangaroo Ground; Kevin Healey, Niddrie; John G. R. Hurrell, Strathmore, all of Australia

[73] Assignee: Commonwealth Serum Laboratories Commission, Parkville, Australia

[\*\*] Term: 14 Years

[21] Appl. No.: 371,048

[22] Filed: Apr. 23, 1982

[52] U.S. Cl. .... D24/55

[58] Field of Search ..... D10/46, 81; D24/51, D24/55, 60, 24; 435/291, 292, 293, 288; 73/863.41, 863.42

[56] References Cited

U.S. PATENT DOCUMENTS

- D. 224,604 8/1972 Huggins ..... D10/96
- D. 252,586 8/1979 Kovach ..... D24/55

- D. 255,665 7/1980 Lewis ..... D10/96
- D. 257,567 11/1980 Peacock ..... D24/55
- 3,855,868 12/1974 Suovaniemi ..... 73/863.32
- 3,963,355 6/1976 Aldridge ..... 435/291 X
- 4,054,491 10/1977 Lindgren ..... D24/60 X
- 4,276,048 6/1981 Leaback ..... 435/291 X
- 4,335,621 6/1982 Teruamäki ..... 73/863.32
- 4,398,382 8/1983 Suovaniemi ..... 435/7 X

Primary Examiner—Nelson C. Holtje  
Attorney, Agent, or Firm—Sughrue, Mion, Zinn, Macpeak and Seas

[57] CLAIM

The ornamental design for a microbiological testing syringe, substantially as shown.

DESCRIPTION

FIG. 1 is a top plan view of a microbiological testing syringe showing our new design; FIG. 2 is a front elevational view thereof; FIG. 3 is a bottom plan view thereof; FIG. 4 is a top and left-front perspective view thereof with the plunger in an extended position.

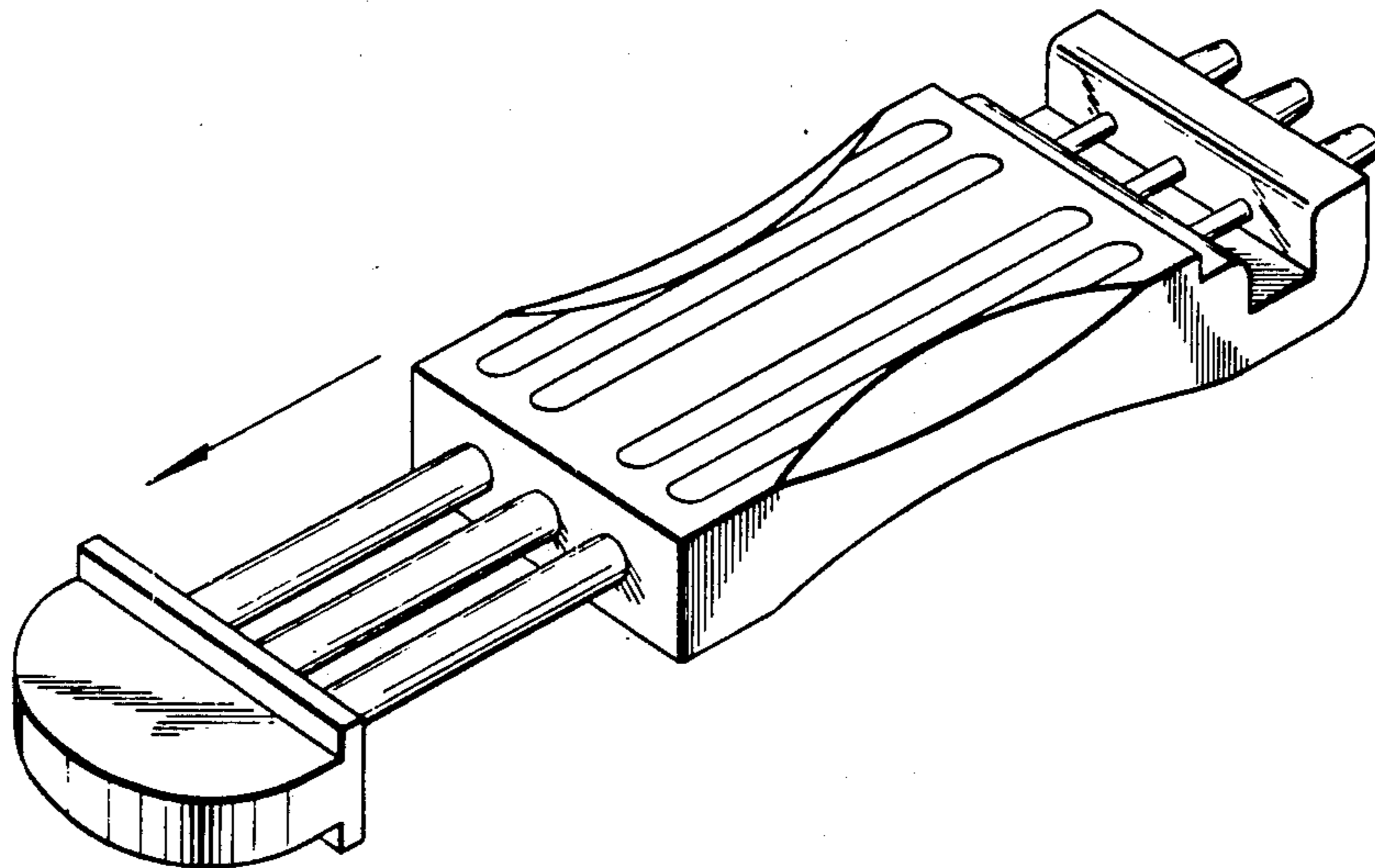

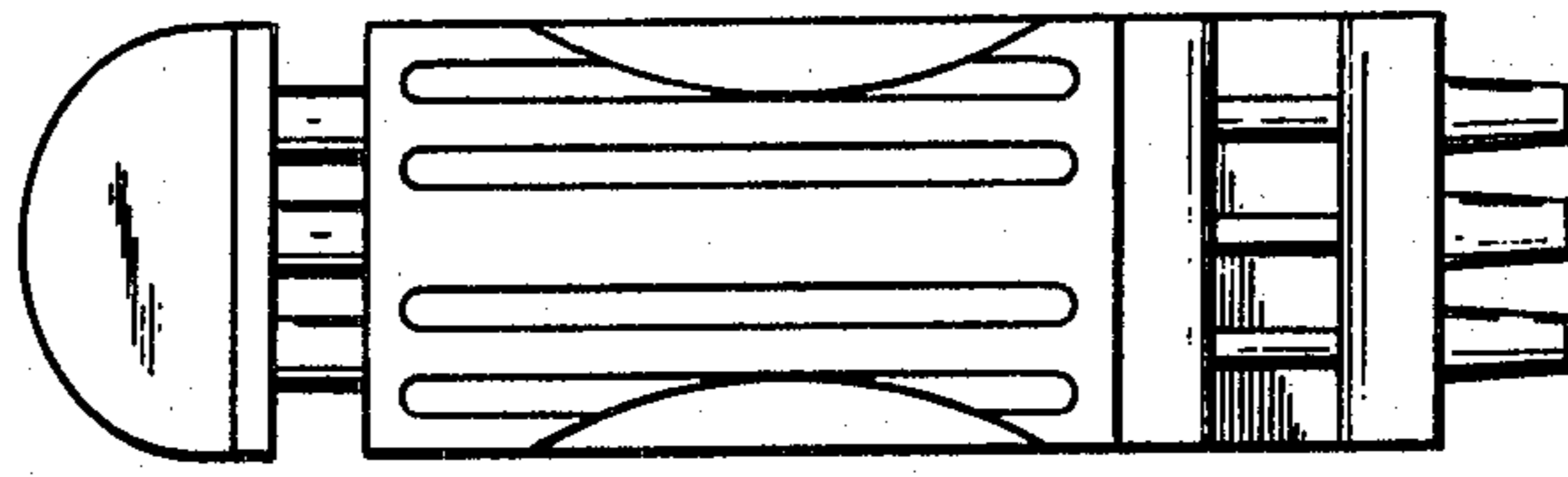

FIG. 1.



FIG. 2.

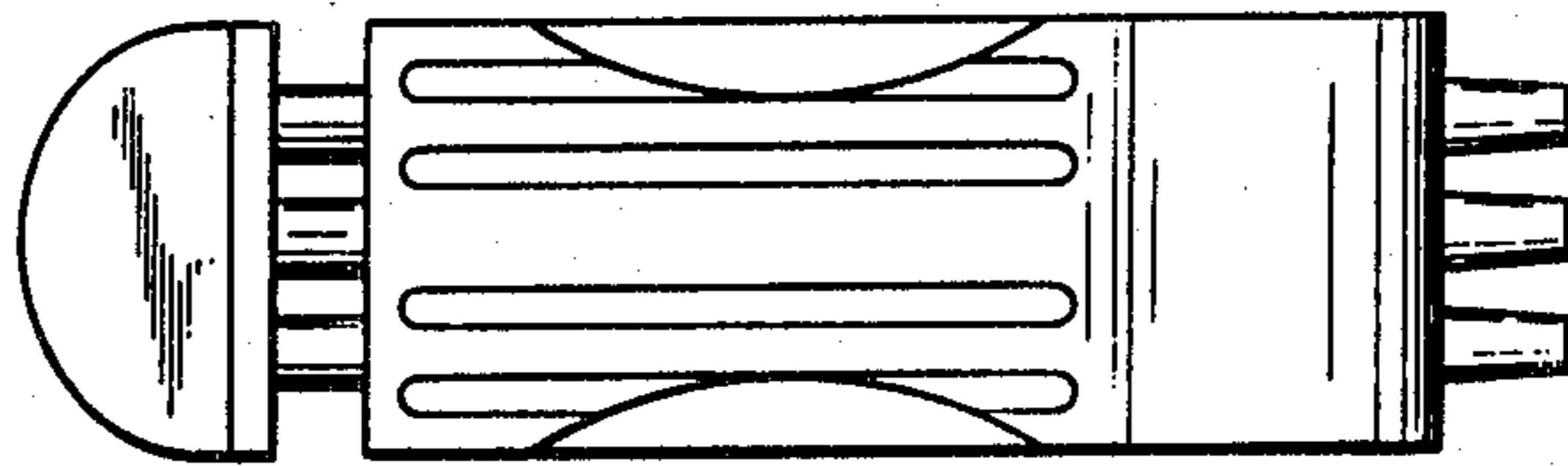

FIG. 3.

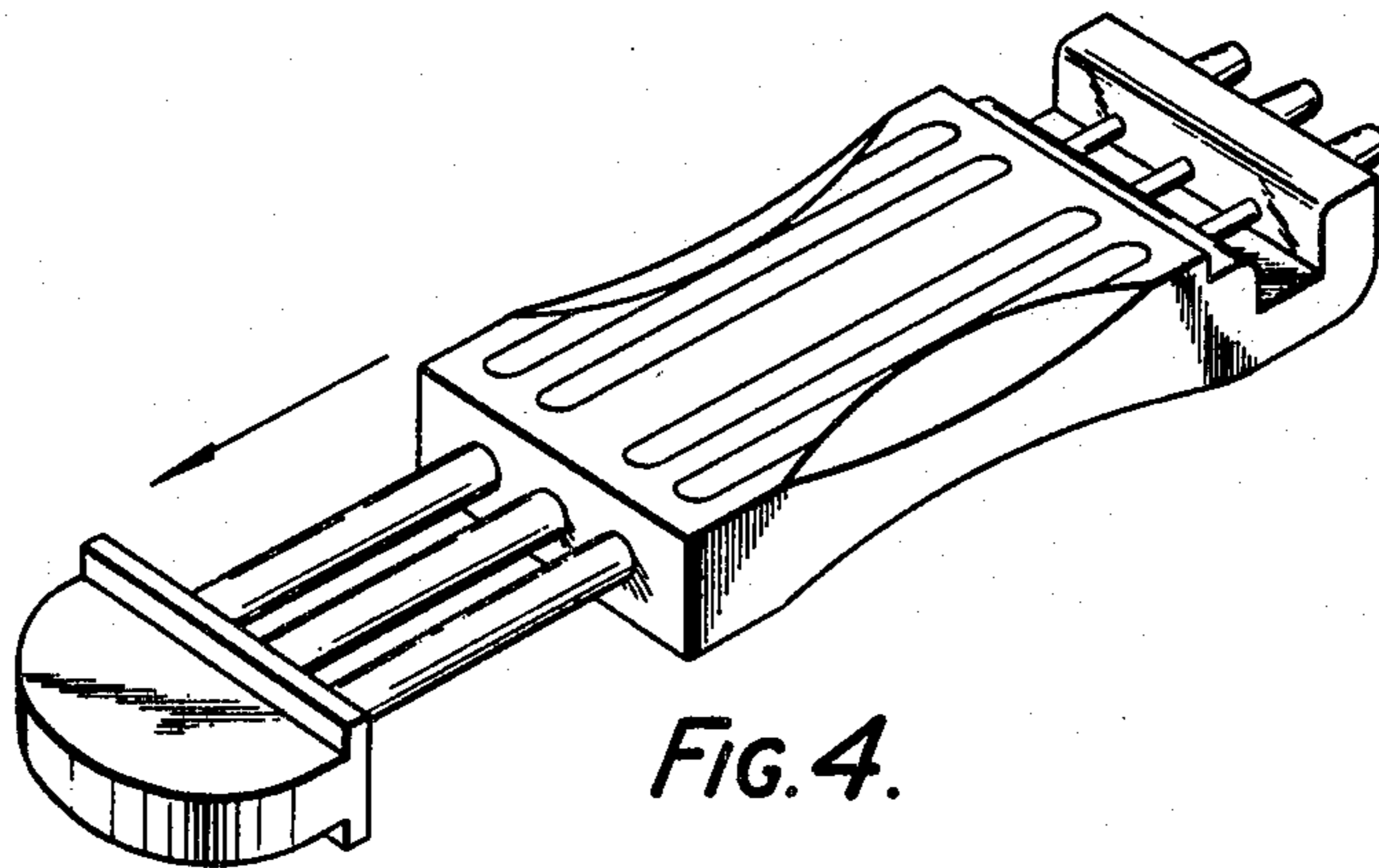

FIG. 4.