

[54] ELEVATOR HOISTING ENGINE

[75] Inventors: Satoru Yokota; Yasutaka Hirano; Tamaiti Kondou, all of Inazawa, Japan

[73] Assignee: Mitsubishi Denki Kabushiki Kaisha, Chiyodaku, Japan

[\*\*] Term: 14 Years

[21] Appl. No.: 532,989

[22] Filed: Sep. 16, 1983

Related U.S. Application Data

[62] Division of Ser. No. 285,877, Jul. 23, 1981.

[30] Foreign Application Priority Data

Feb. 5, 1981 [JP]	Japan	56-4254
Feb. 5, 1981 [JP]	Japan	56-4256
Feb. 5, 1981 [JP]	Japan	56-4257
May 18, 1981 [JP]	Japan	56-21312
May 18, 1981 [JP]	Japan	56-21313
May 18, 1981 [JP]	Japan	56-21314
May 18, 1981 [JP]	Japan	56-21315
[52] U.S. Cl.		D15/1
[58] Field of Search		D15/1; 187/20, 26; 254/362

[56] References Cited

U.S. PATENT DOCUMENTS

D. 131,705	3/1942	Schreck	D15/1
D. 179,236	11/1956	Bernard	D15/1
D. 239,329	3/1976	Schramm	D15/1
3,223,385	12/1965	Murakami	254/362
3,261,591	7/1966	Campbell et al.	254/362
4,314,692	2/1982	Braver et al.	254/362

Primary Examiner—Wallace R. Burke  
Assistant Examiner—Lynn Wilder  
Attorney, Agent, or Firm—Wenderoth, Lind & Ponack

[57] CLAIM

The ornamental design for an elevator hoisting engine, substantially as shown.

DESCRIPTION

FIG. 1 is a front elevational view of an elevator hoisting engine, showing our new design; FIG. 2 is a rear elevational view thereof; FIG. 3 is a top plan view thereof; FIG. 4 is a bottom plan view thereof; FIG. 5 is a left side elevational view thereof; FIG. 6 is a right side elevational view thereof; and FIG. 7 is a perspective view thereof; FIG. 8 is a front elevational view of a second embodiment of an elevator hoisting engine showing our new design; FIG. 9 is a rear elevational view thereof; FIG. 10 is a top plan view thereof; FIG. 11 is a bottom plan view thereof; FIG. 12 is a left side elevational view thereof; and FIG. 13 is a right side elevational view thereof.

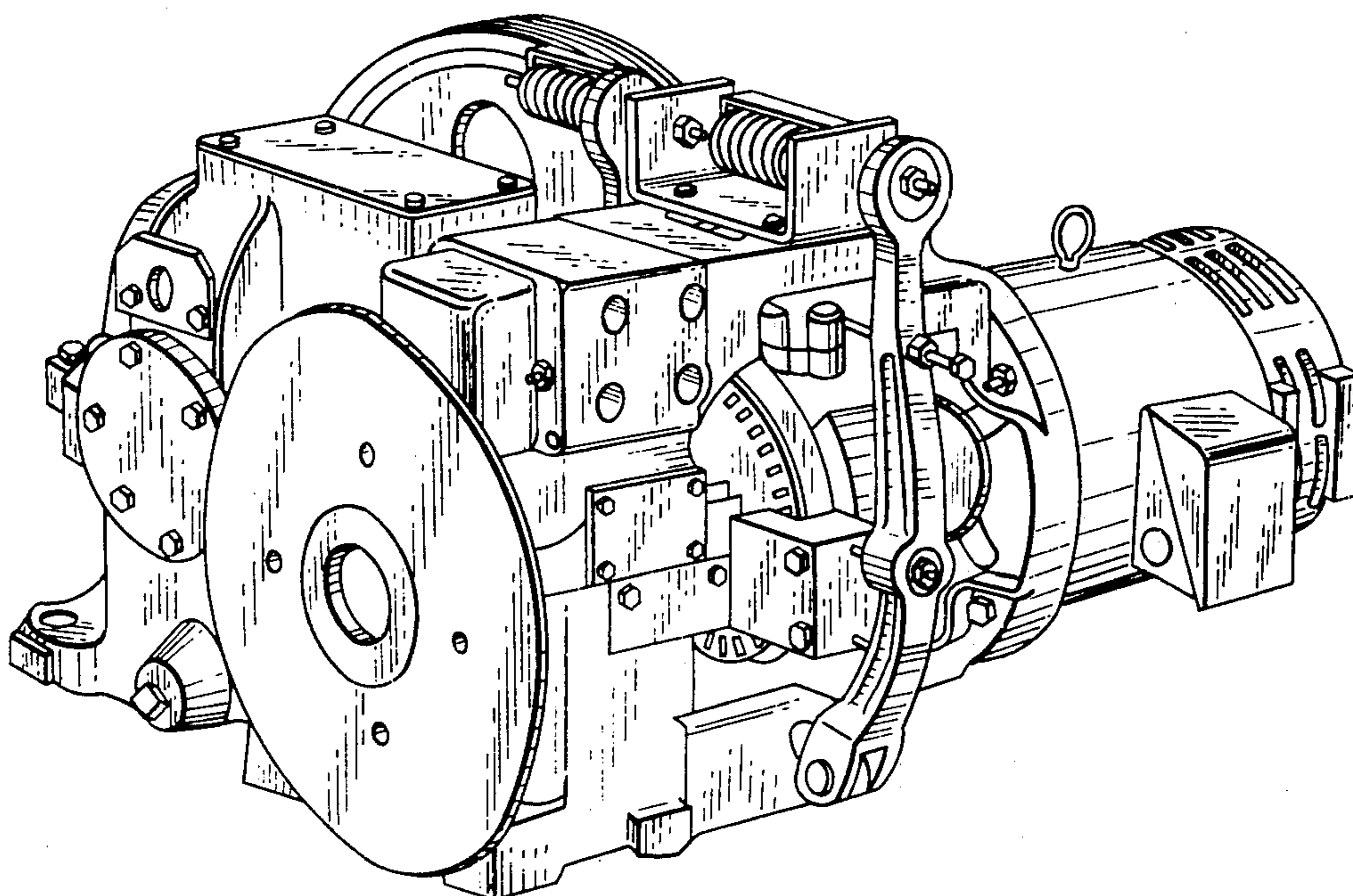

FIG. 1

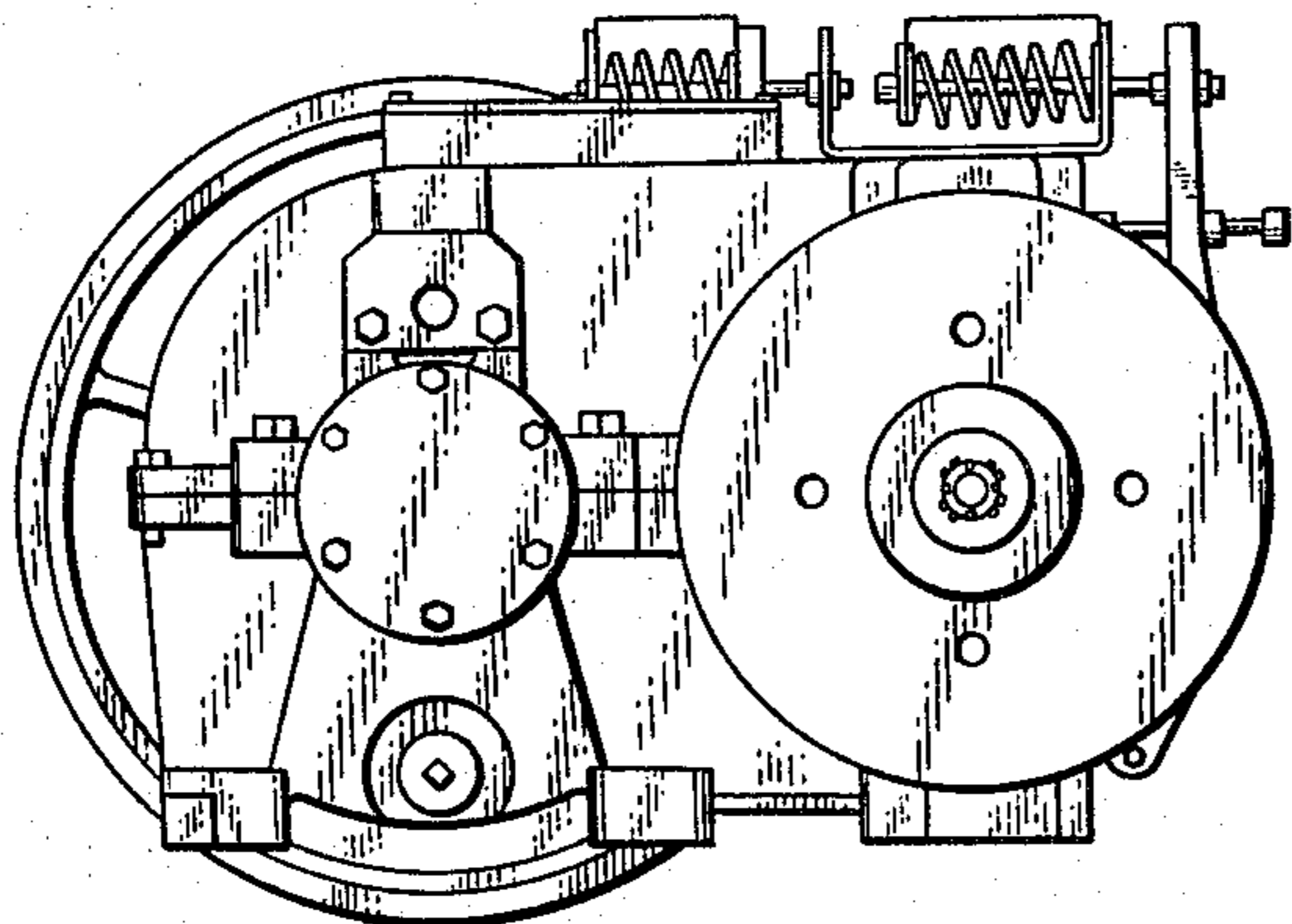

FIG. 2

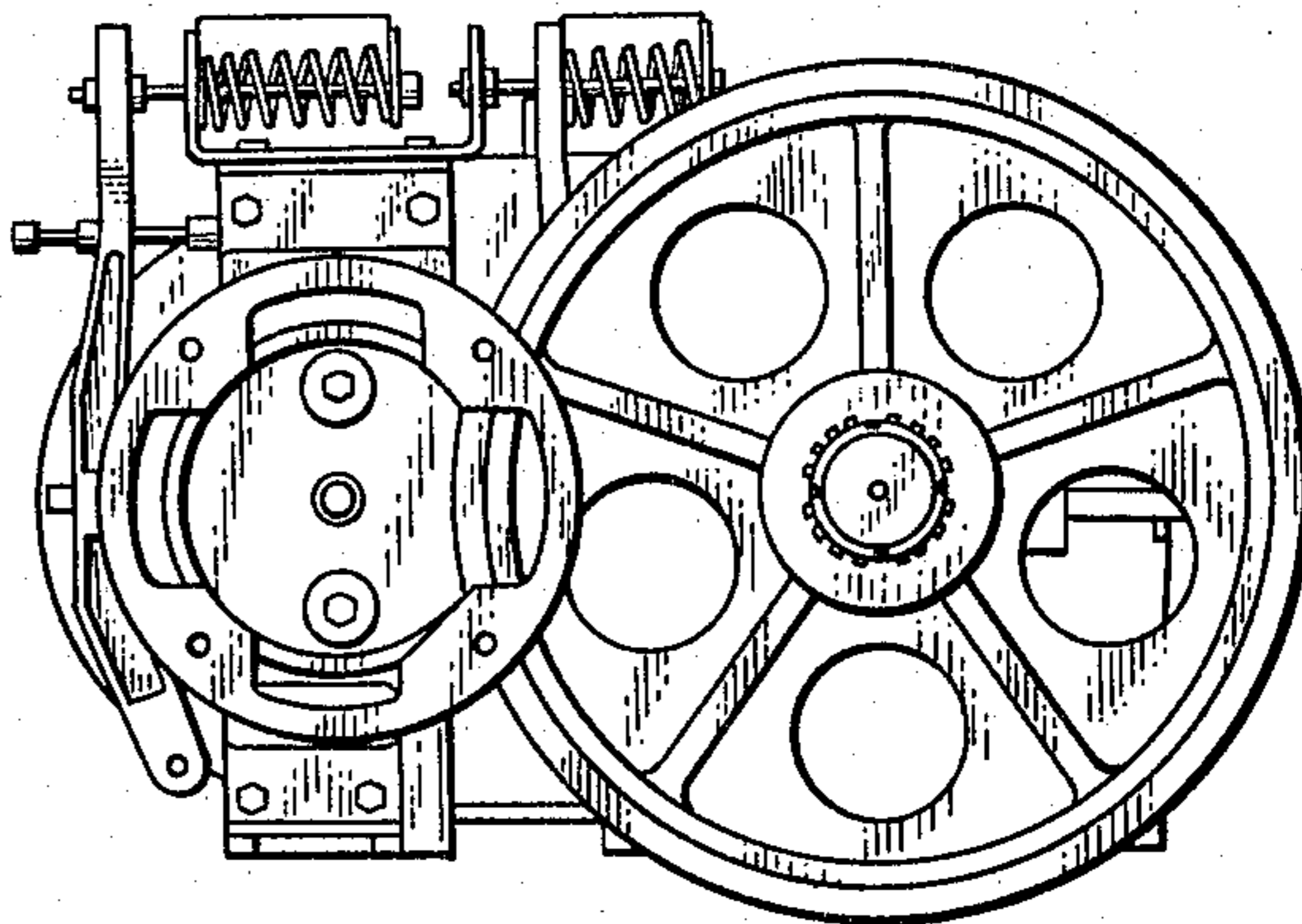

FIG. 3

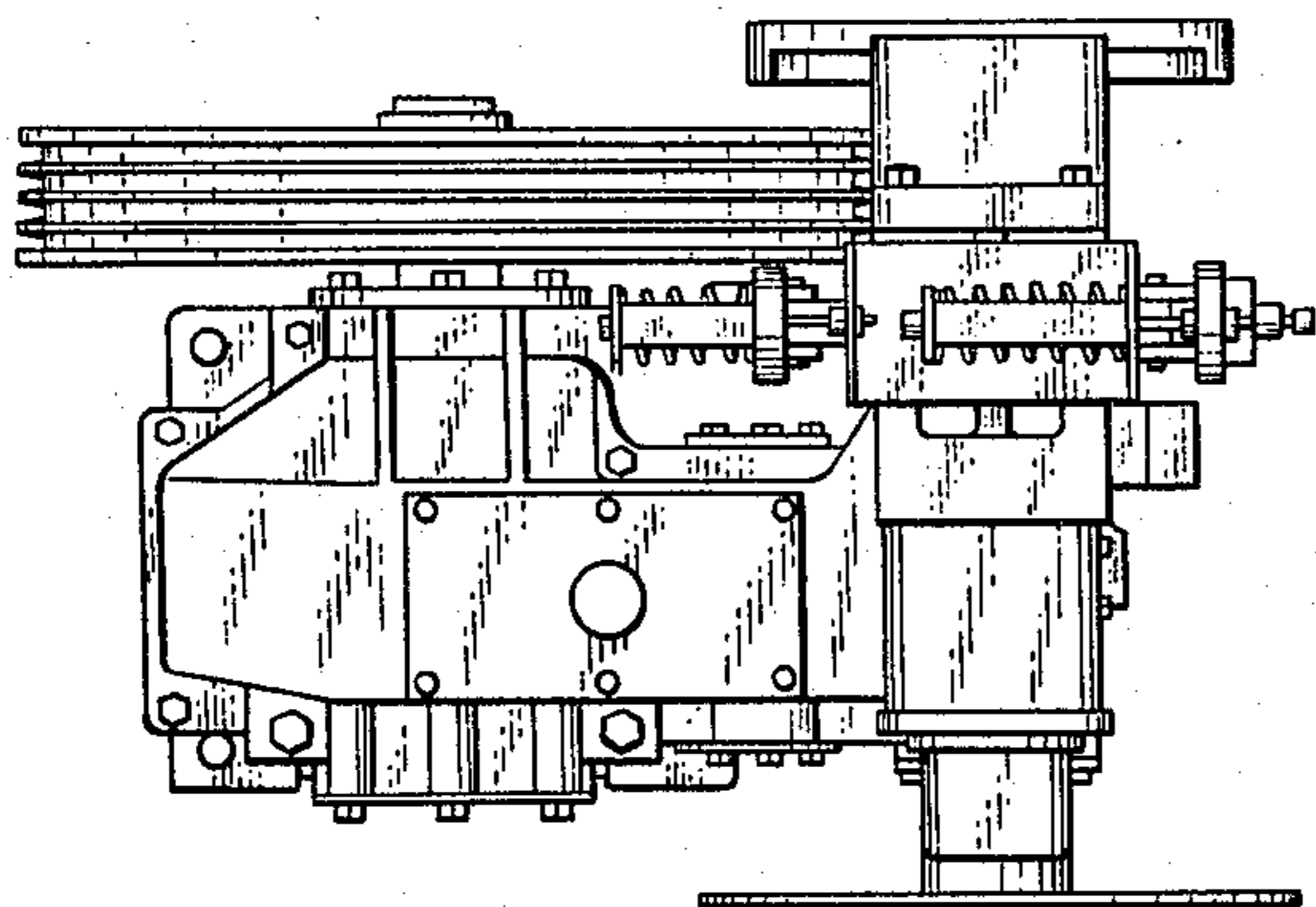

FIG. 4

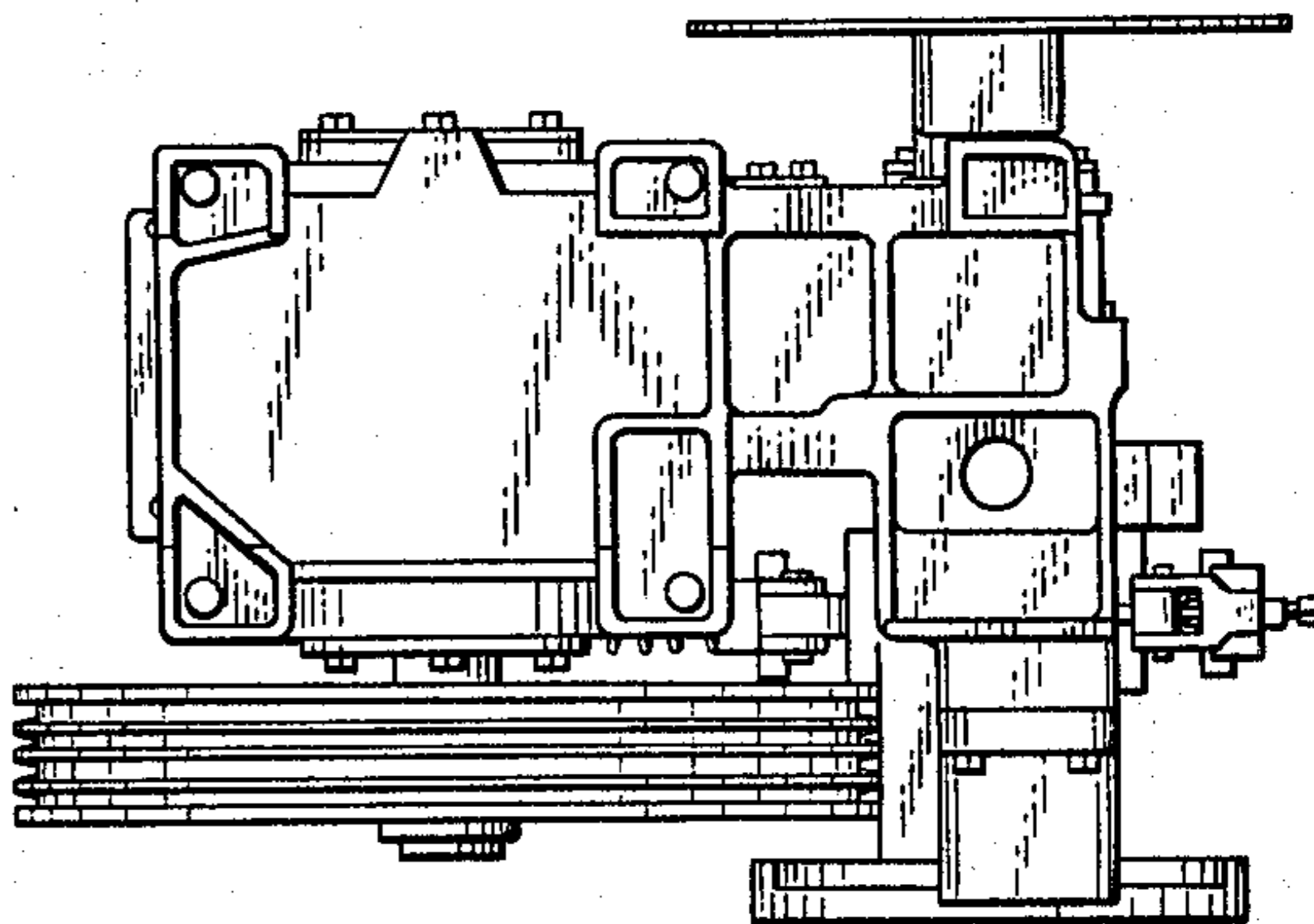

FIG. 5

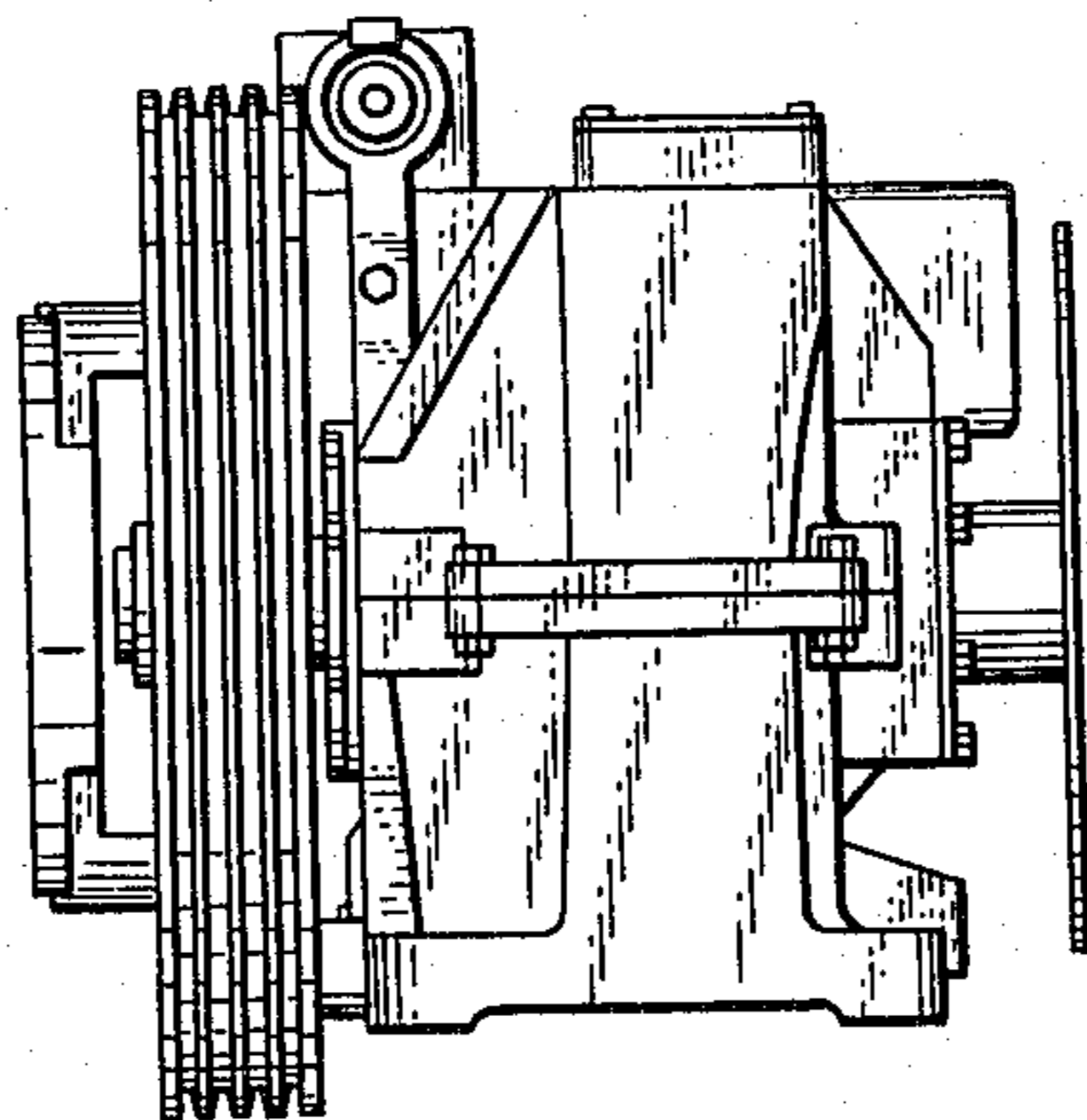

FIG. 6

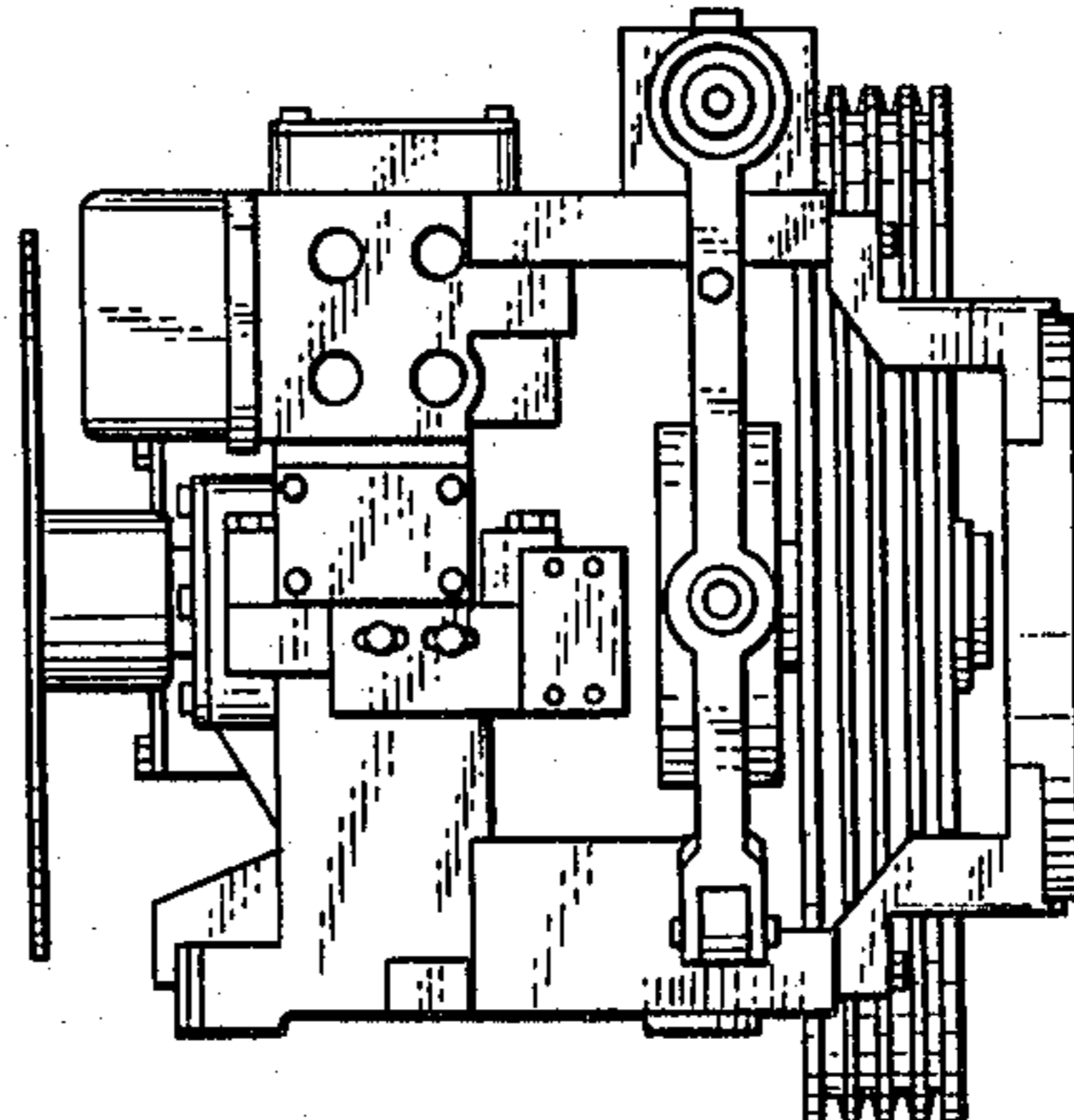

FIG. 7

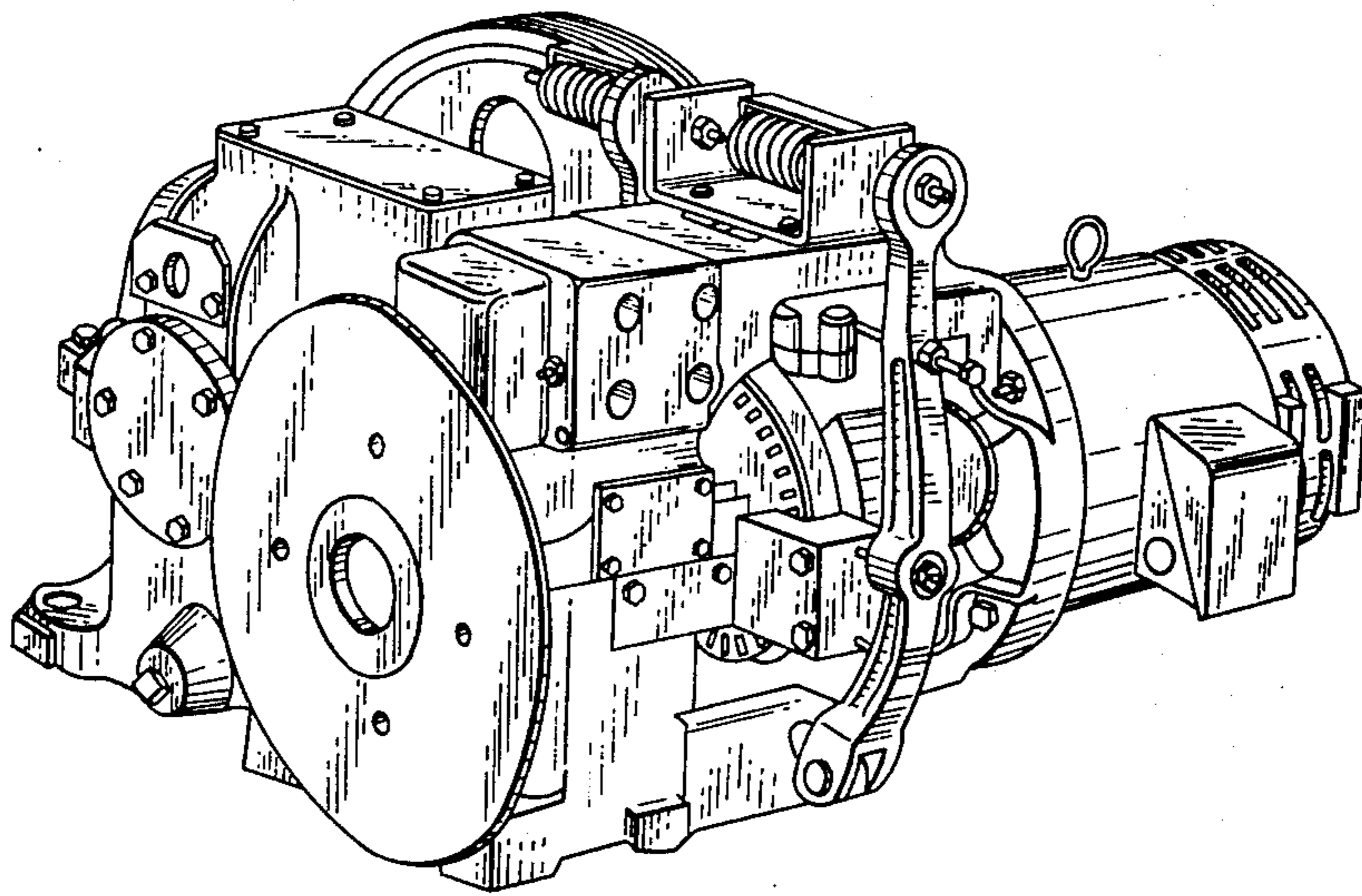

FIG. 8

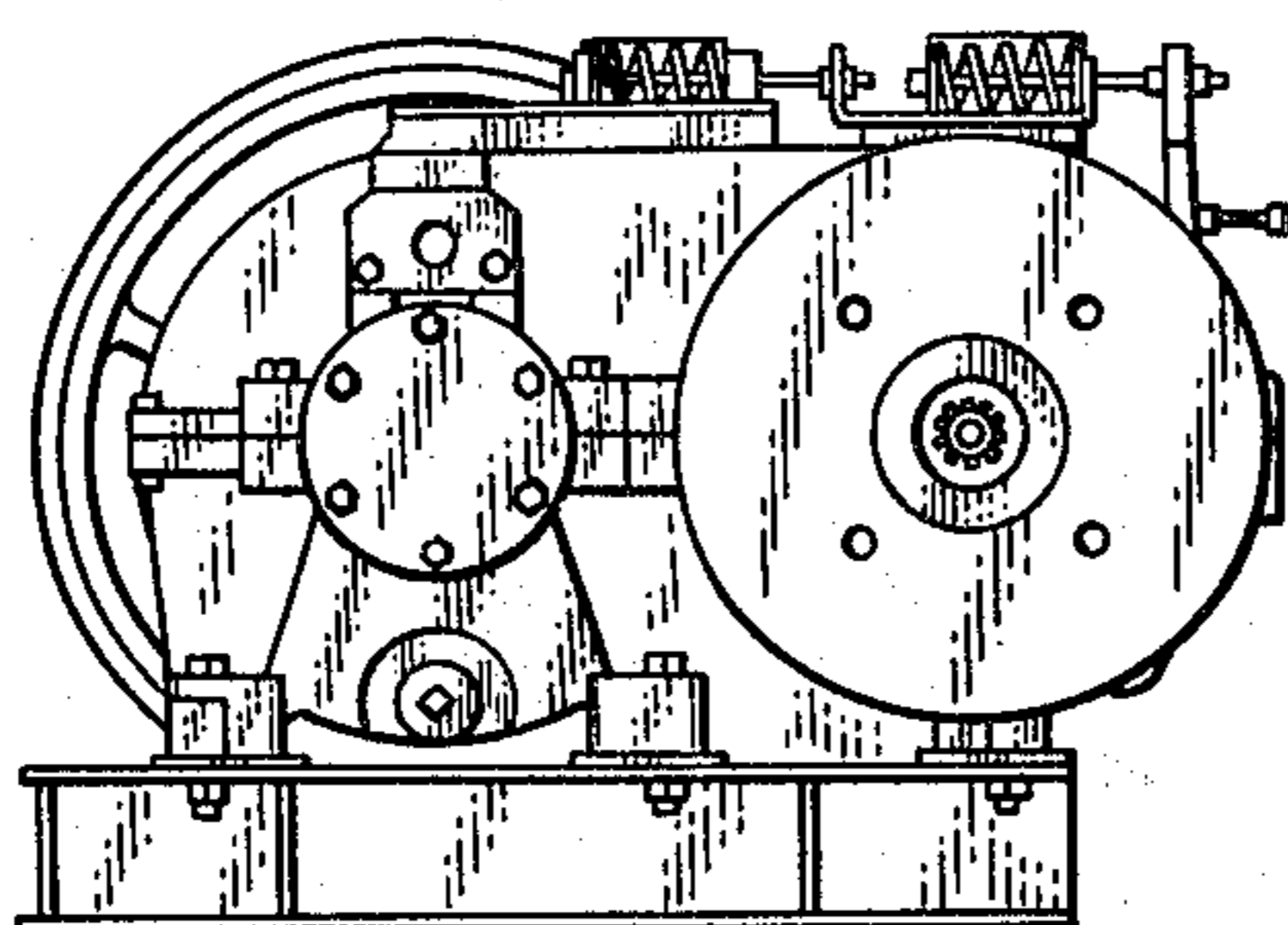

FIG. 9

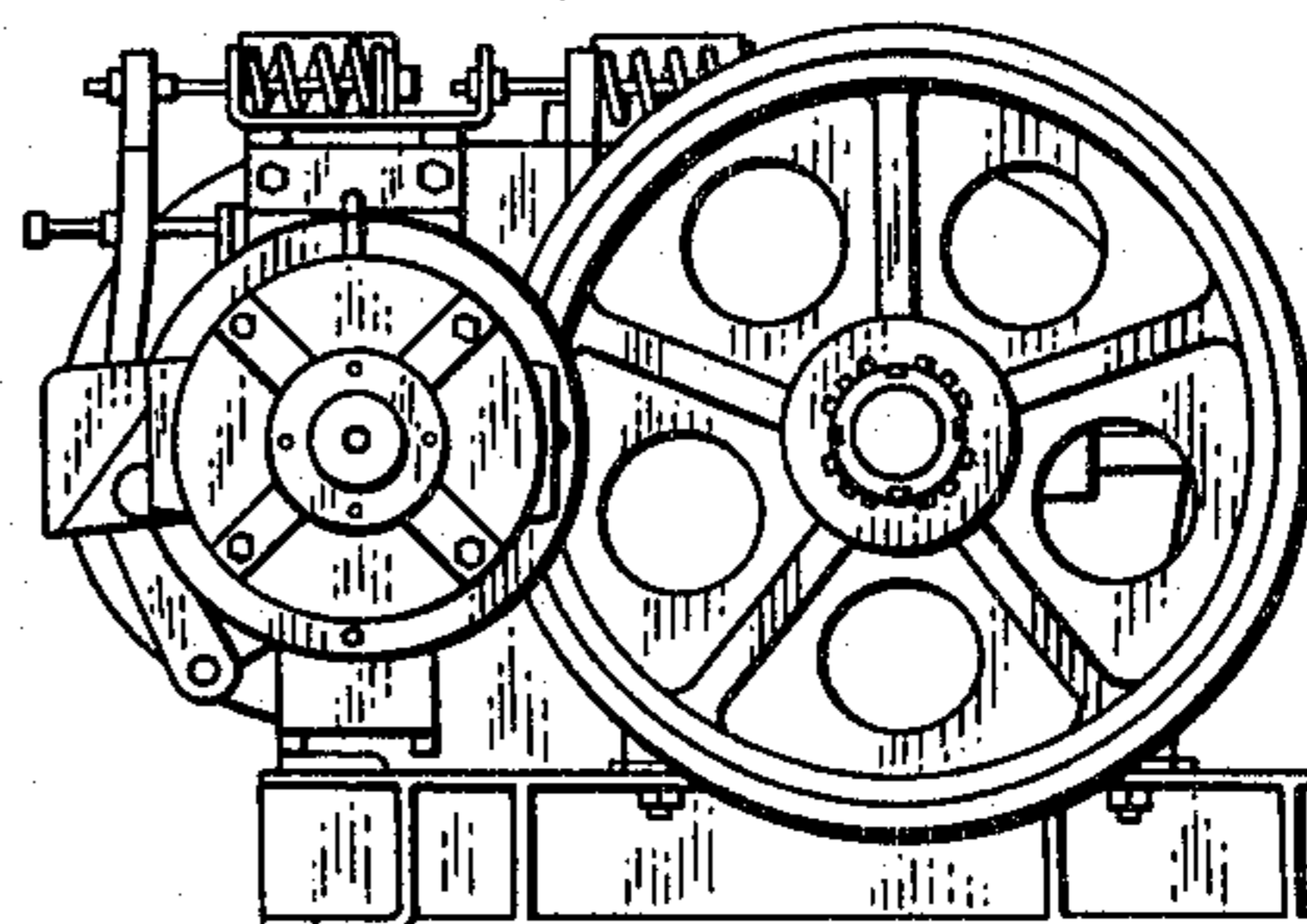

FIG. 10

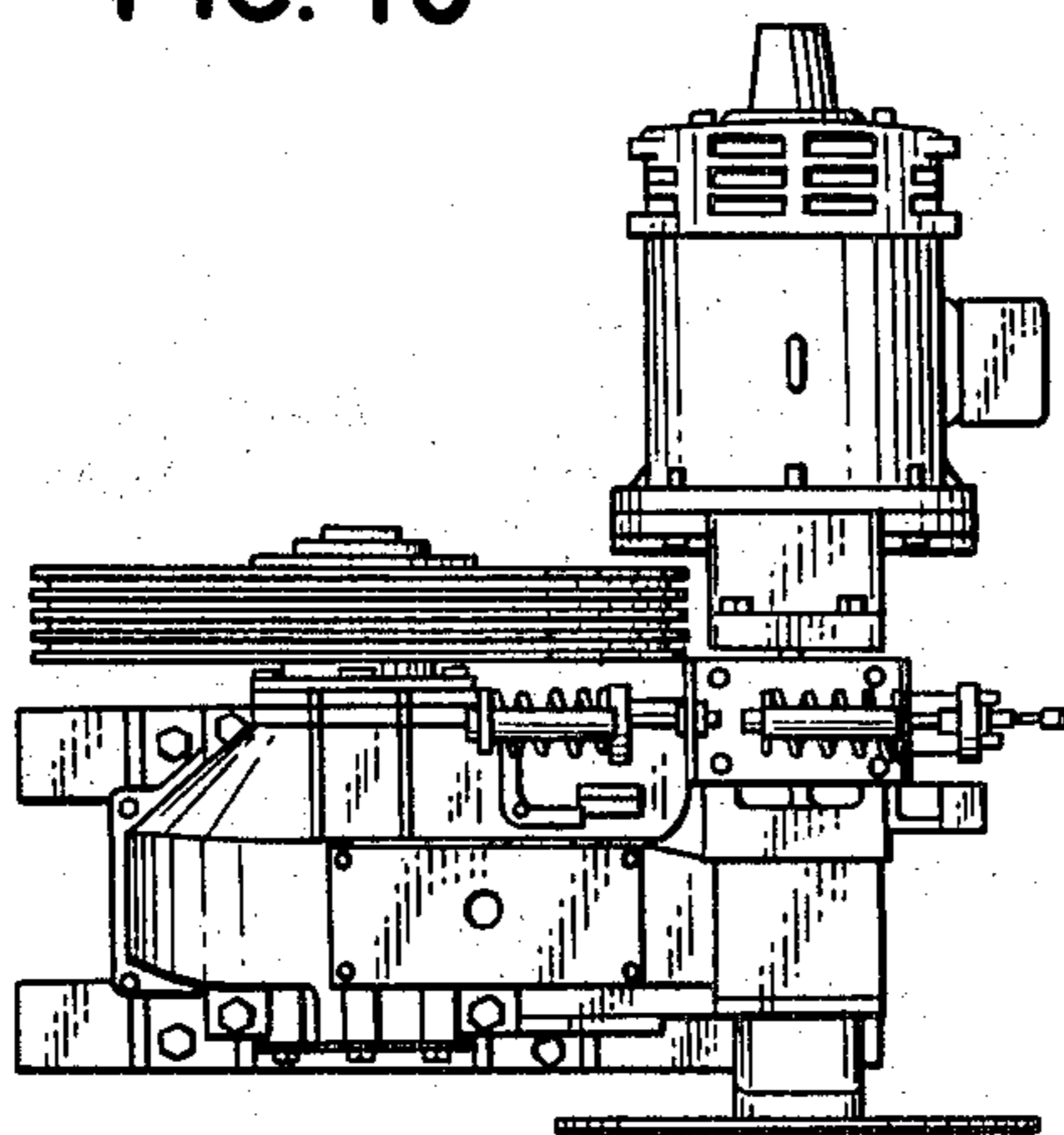

FIG. 11

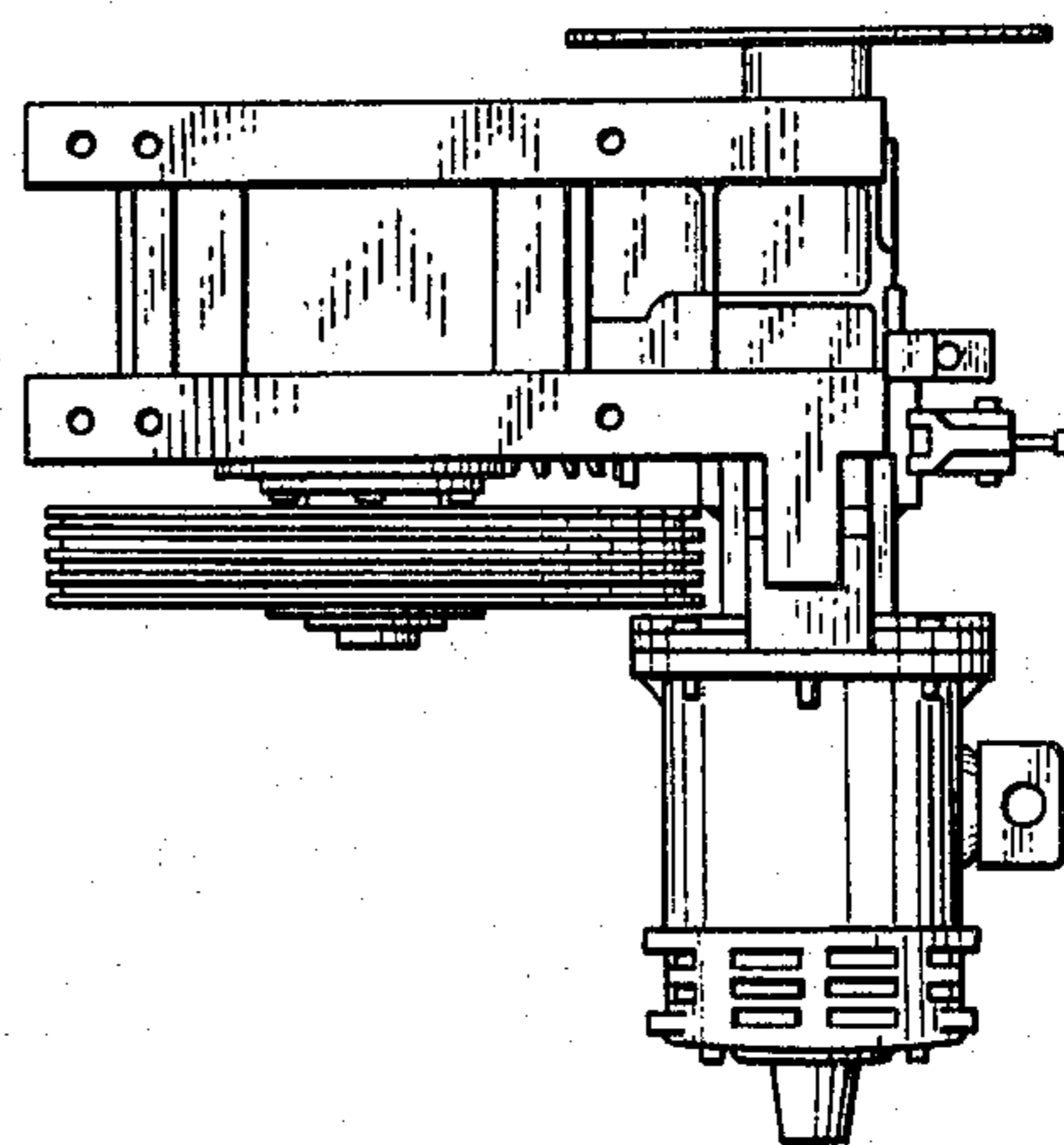

FIG. 12

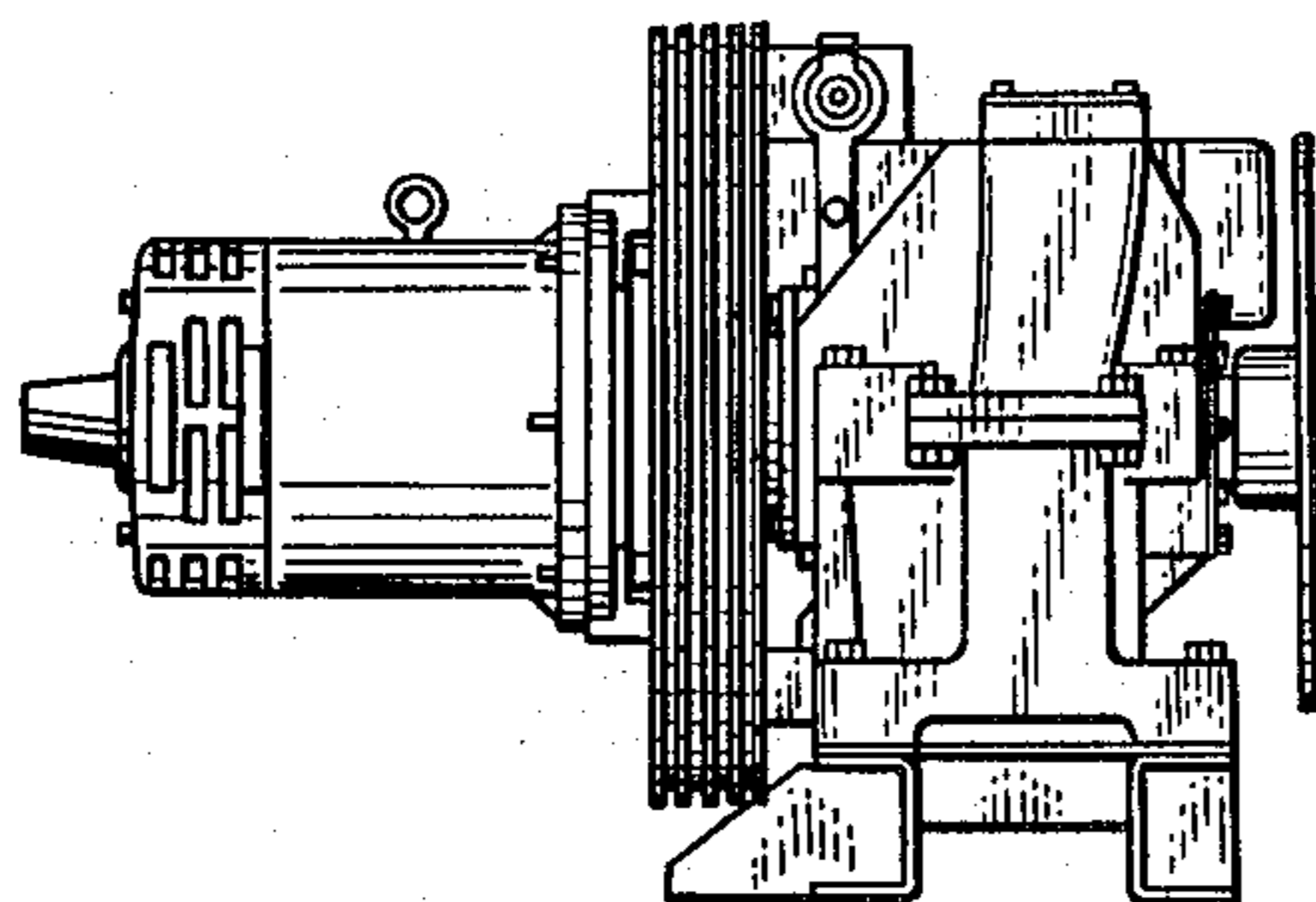

FIG. 13

