

[54] ELECTRONIC TIMBRE CONTROLLER FOR MUSICAL INSTRUMENTS

[76] Inventor: Emmett H. Chapman, 8320 Yucca Trail, Los Angeles, Calif. 90046

[\*\*] Term: 14 Years

[21] Appl. No.: 359,930

[22] Filed: Mar. 19, 1982

[52] U.S. Cl. .... D17/20; D17/99

[58] Field of Search ..... D17/20, 99

[56] References Cited

PUBLICATIONS

*The Music Trades*, 1-81, p. 27, Multivox Big Jam Effects Pedal System.

*The Music Trades*, 4-81, p. 44, Morley Effect Box.

Primary Examiner—Jane E. Corrigan  
Attorney, Agent, or Firm—J. E. McTaggart

[57] CLAIM

The ornamental design for an electronic timbre controller for musical instruments, as shown and described.

DESCRIPTION

FIG. 1 is a front, top and left side perspective view of an electronic timbre controller for musical instruments showing my new design;

FIG. 2 is a front elevational view;

FIG. 3 is a right side elevational view;

FIG. 4 is a rear elevational view;

FIG. 5 is a top plan view; and

FIG. 6 is a bottom plan view.

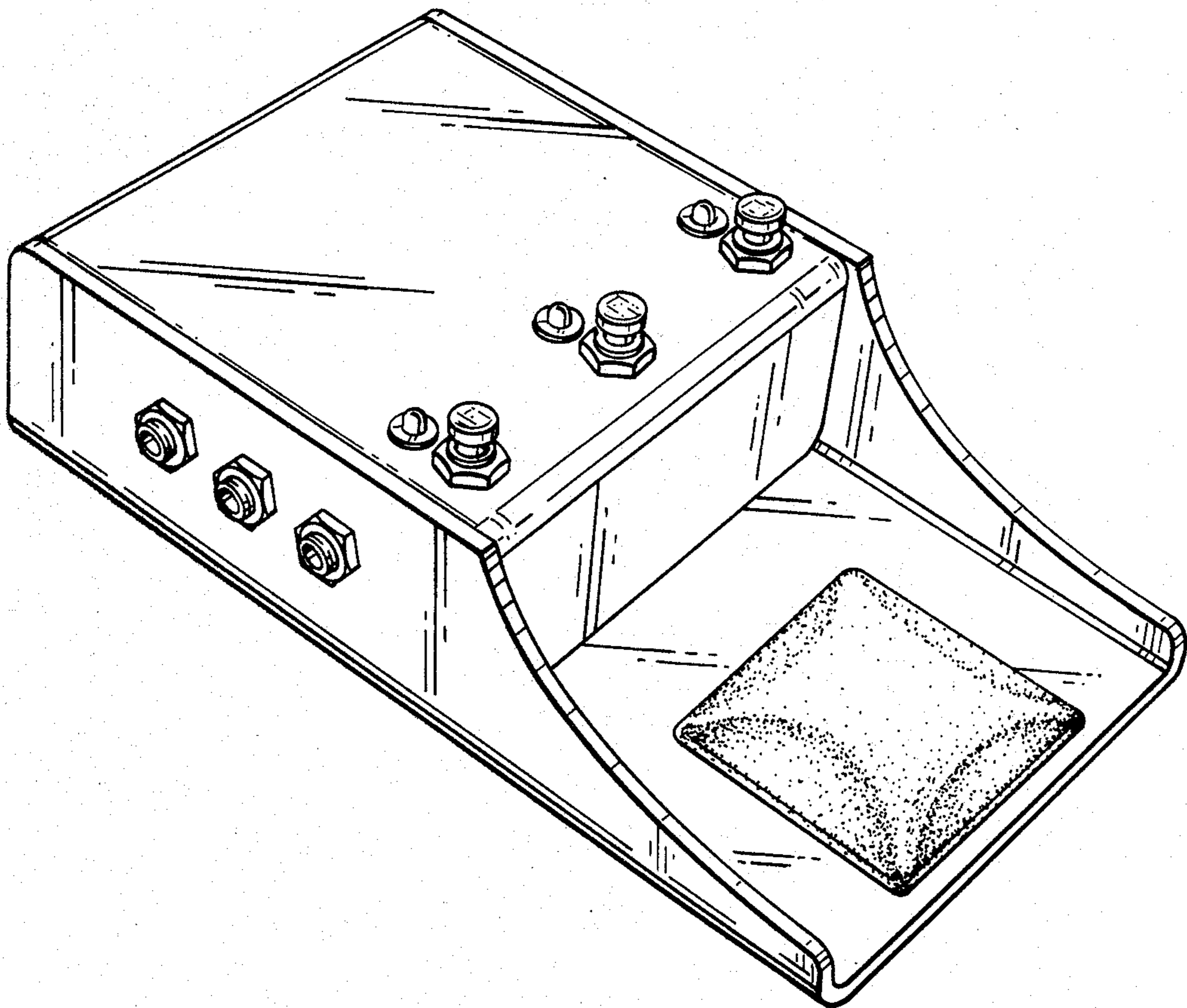

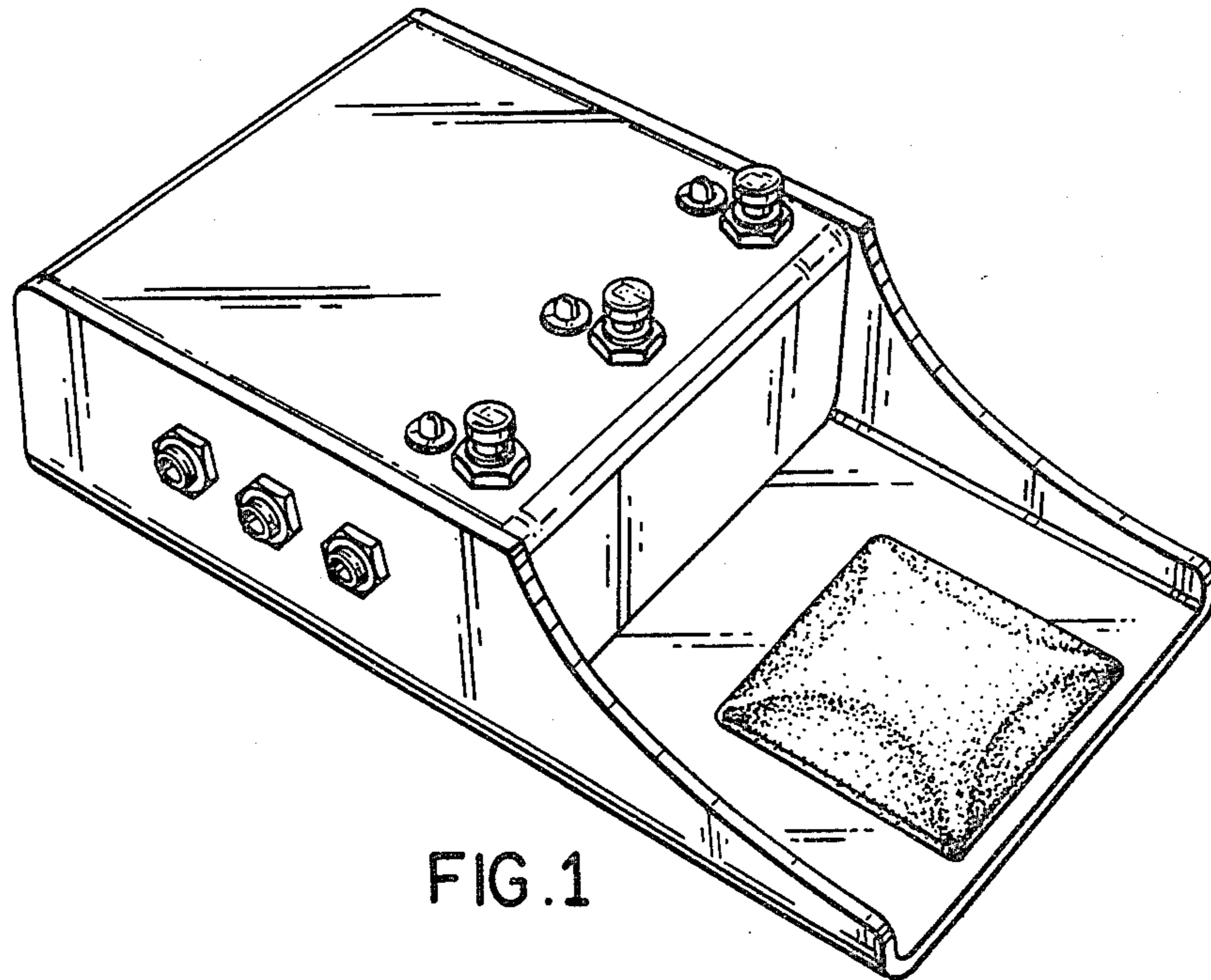

FIG. 1

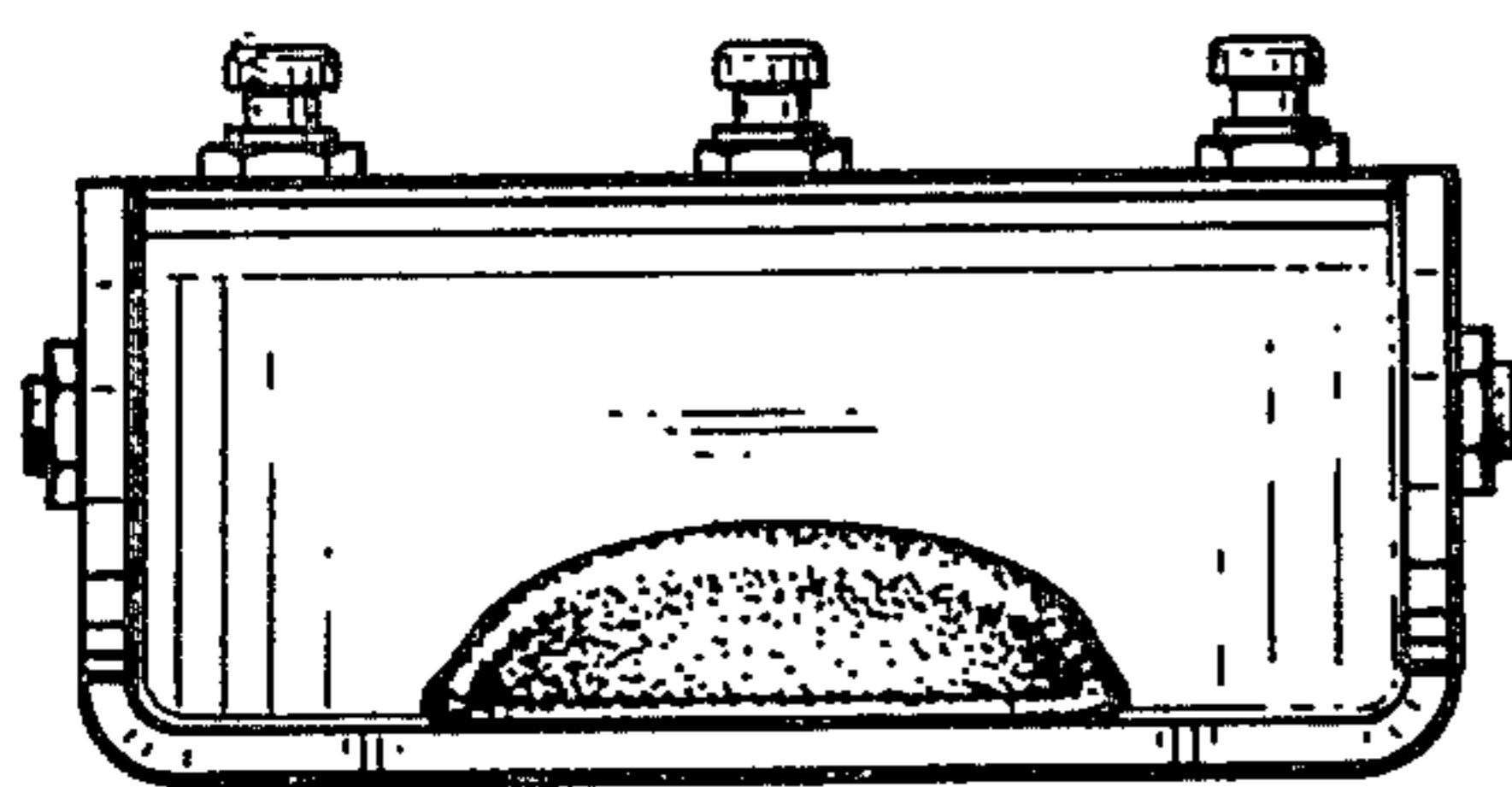

FIG. 2

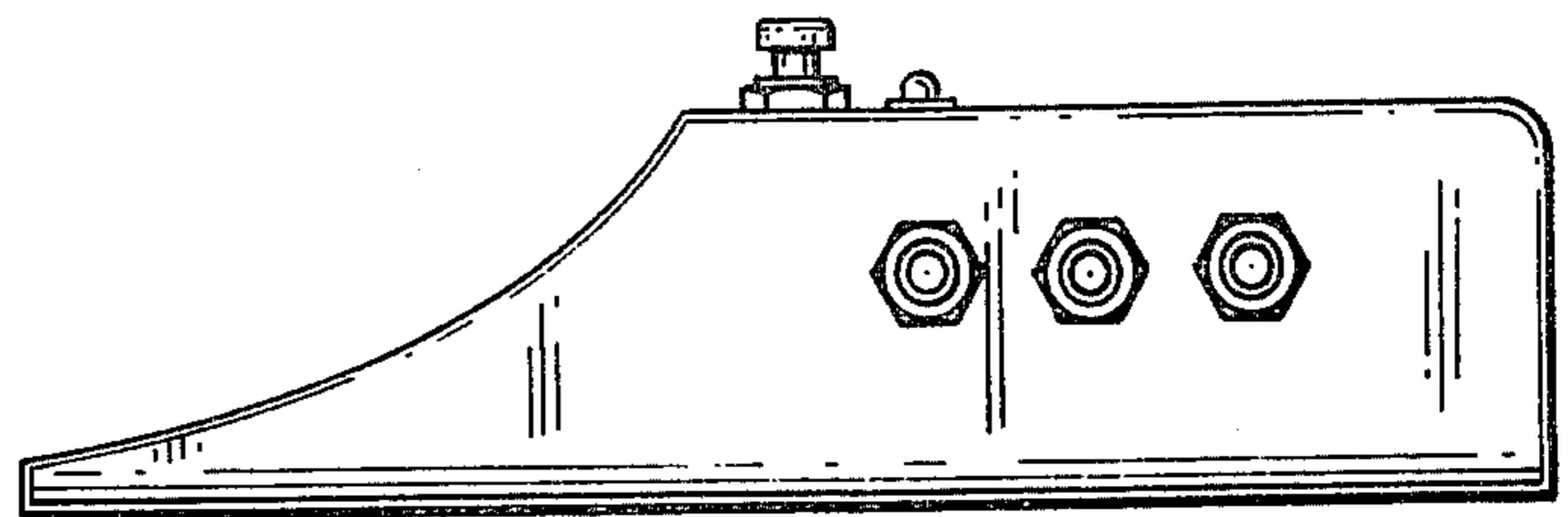

FIG. 3

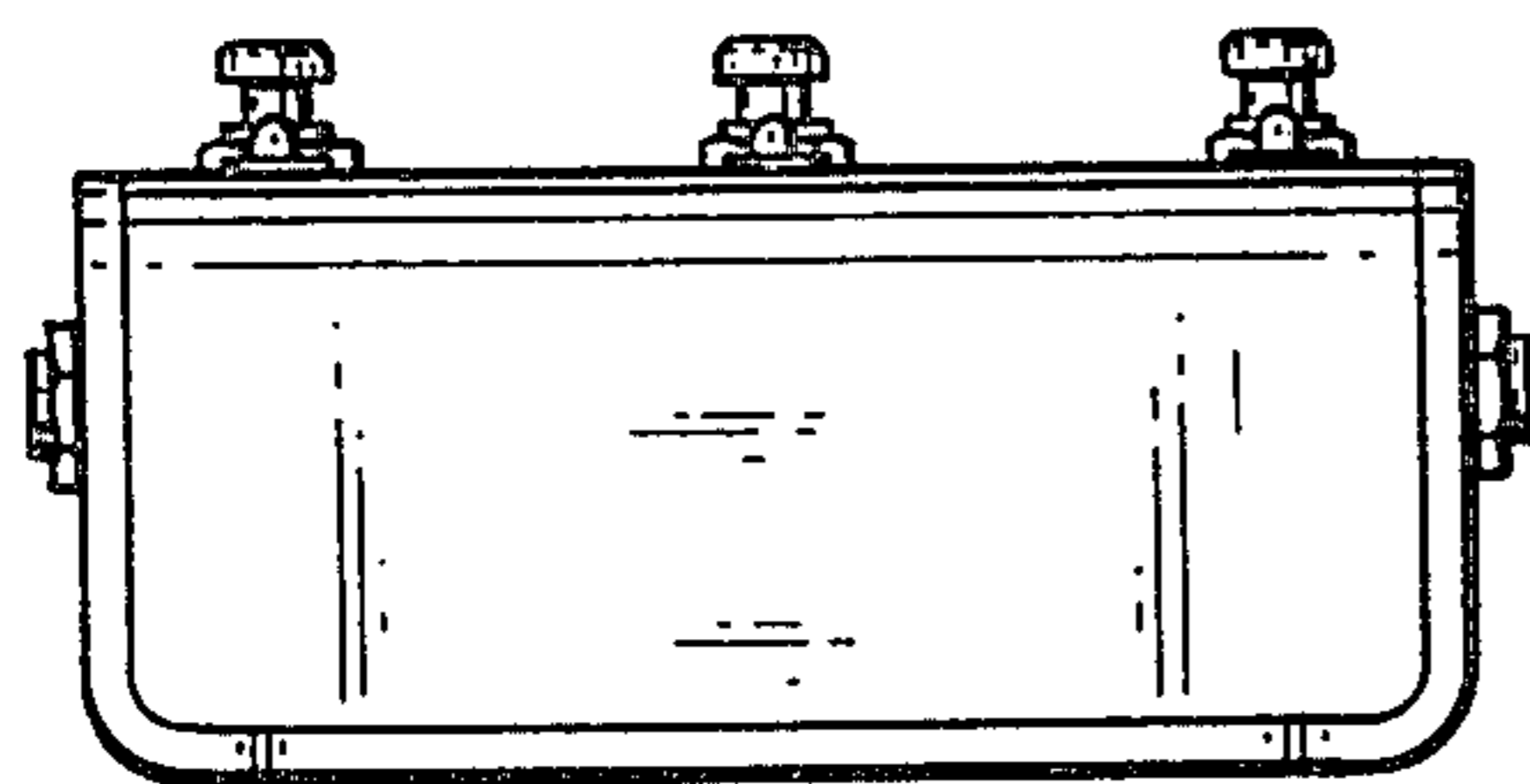

FIG. 4

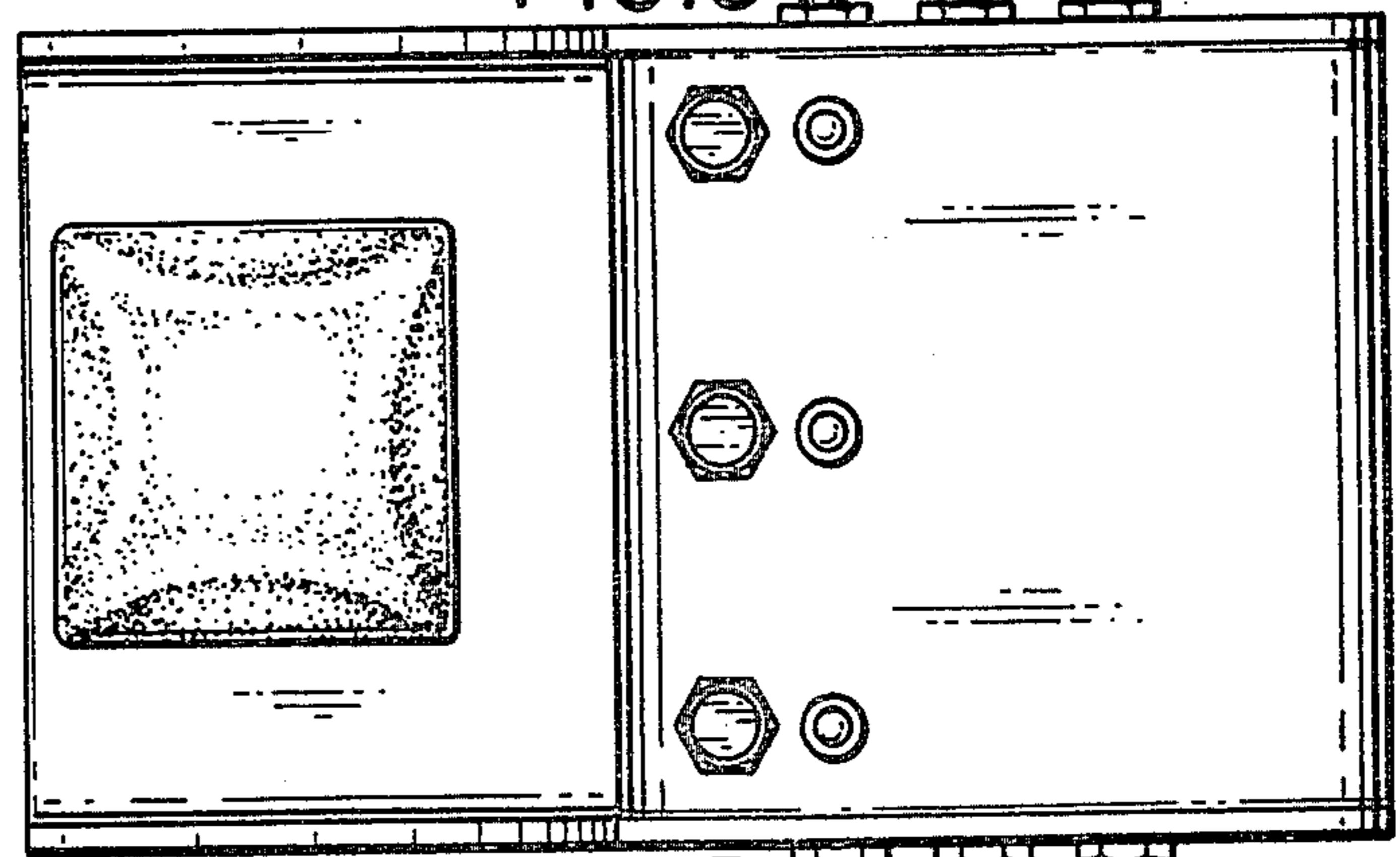

FIG. 5

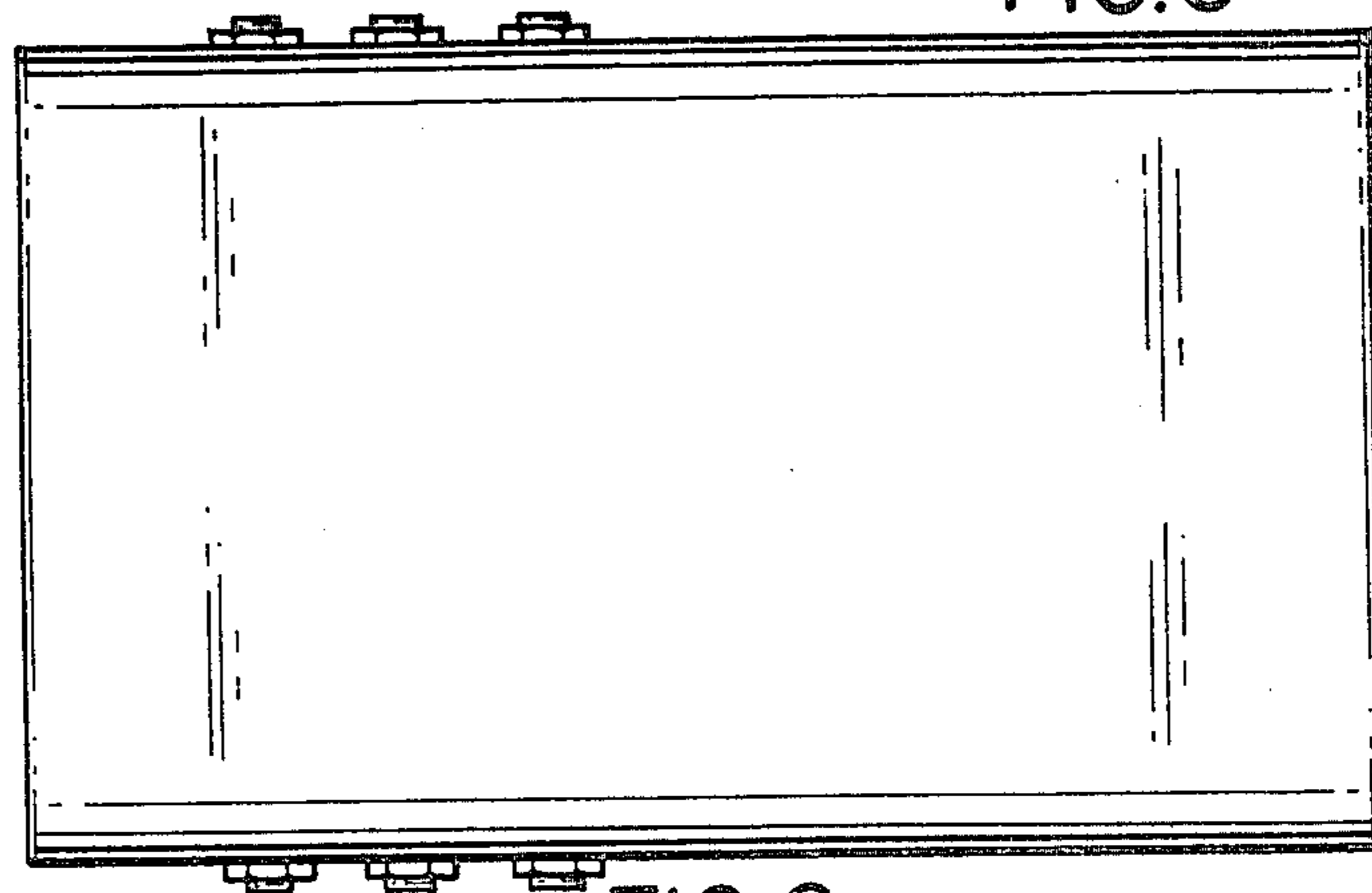

FIG. 6