

[54] MOTORCYCLE

[75] Inventors: Bernard Lacroix, Montbeliard;
Daniel Coulon, Seloncourt, both of
France

[73] Assignee: Cycles Peugeot, France

[**] Term: 14 Years

[21] Appl. No.: 323,020

[22] Filed: Nov. 19, 1981

[30] Foreign Application Priority Data

May 22, 1981 [FR] France 811873

[52] U.S. Cl. D12/110

[58] Field of Search D12/110; 180/219, 220

[56] References Cited

U.S. PATENT DOCUMENTS

D. 264,704 6/1982 Rehberg D12/114

OTHER PUBLICATIONS

American Bicyclist & Motorcyclist, 7/80, p. 27, Tomos Moped.

Motorcyclist, 4/81, p. 90, Yamaha Poet, bottom right side of page.

Primary Examiner—James M. Gandy
Attorney, Agent, or Firm—Kuhn, Muller and Bazerman

[57] CLAIM

The ornamental design for a motorcycle, as shown.

DESCRIPTION

FIG. 1 is a side elevation view of a motorcycle showing our new design;

FIG. 2 is a top perspective view thereof;

FIG. 3 is a side elevational view thereof opposite to that shown in FIG. 1;

FIG. 4 is a bottom perspective view thereof;

FIG. 5 is an enlarged front perspective view thereof; and

FIG. 6 is an enlarged rear perspective view thereof.

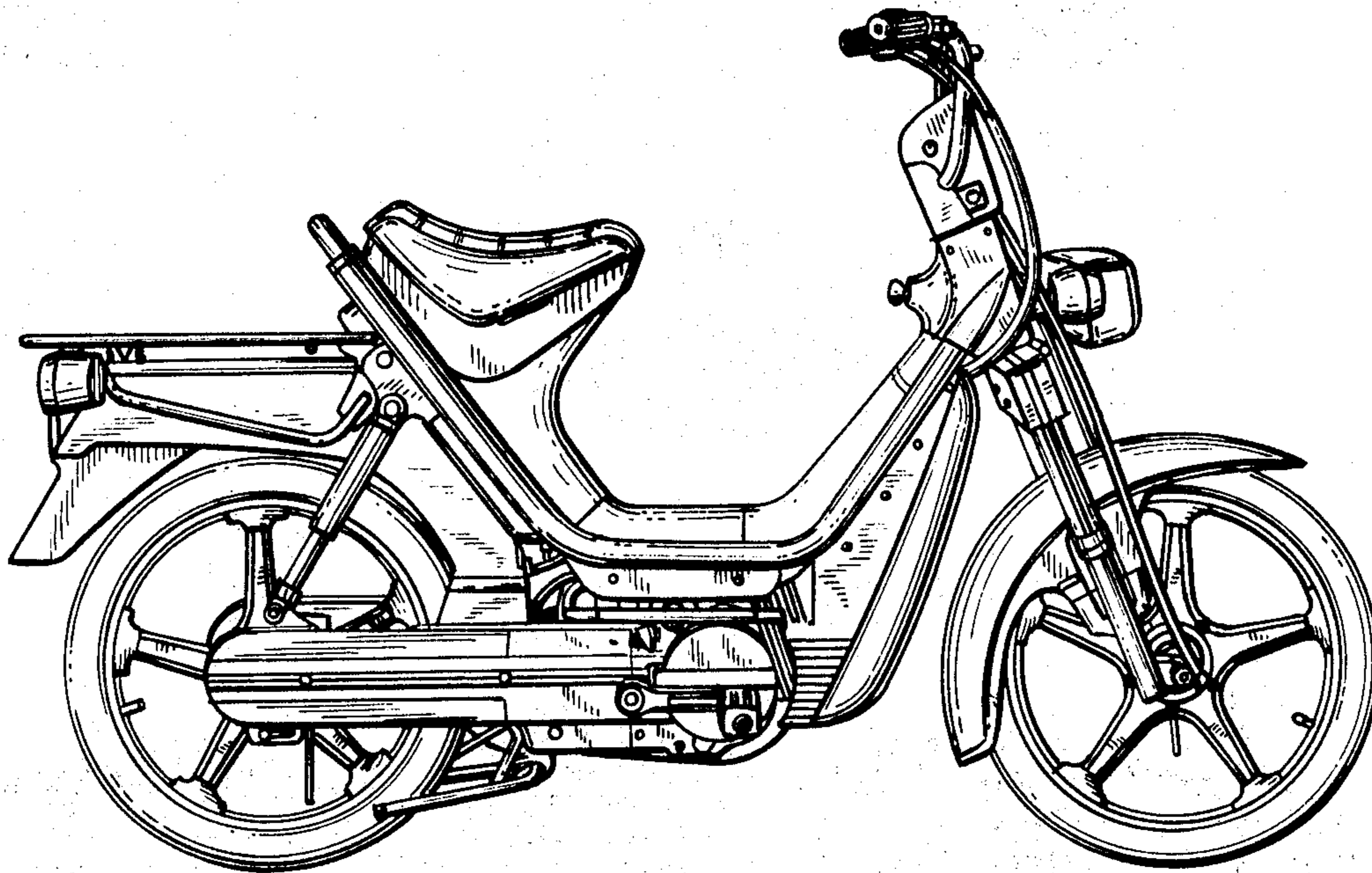

FIG. 1

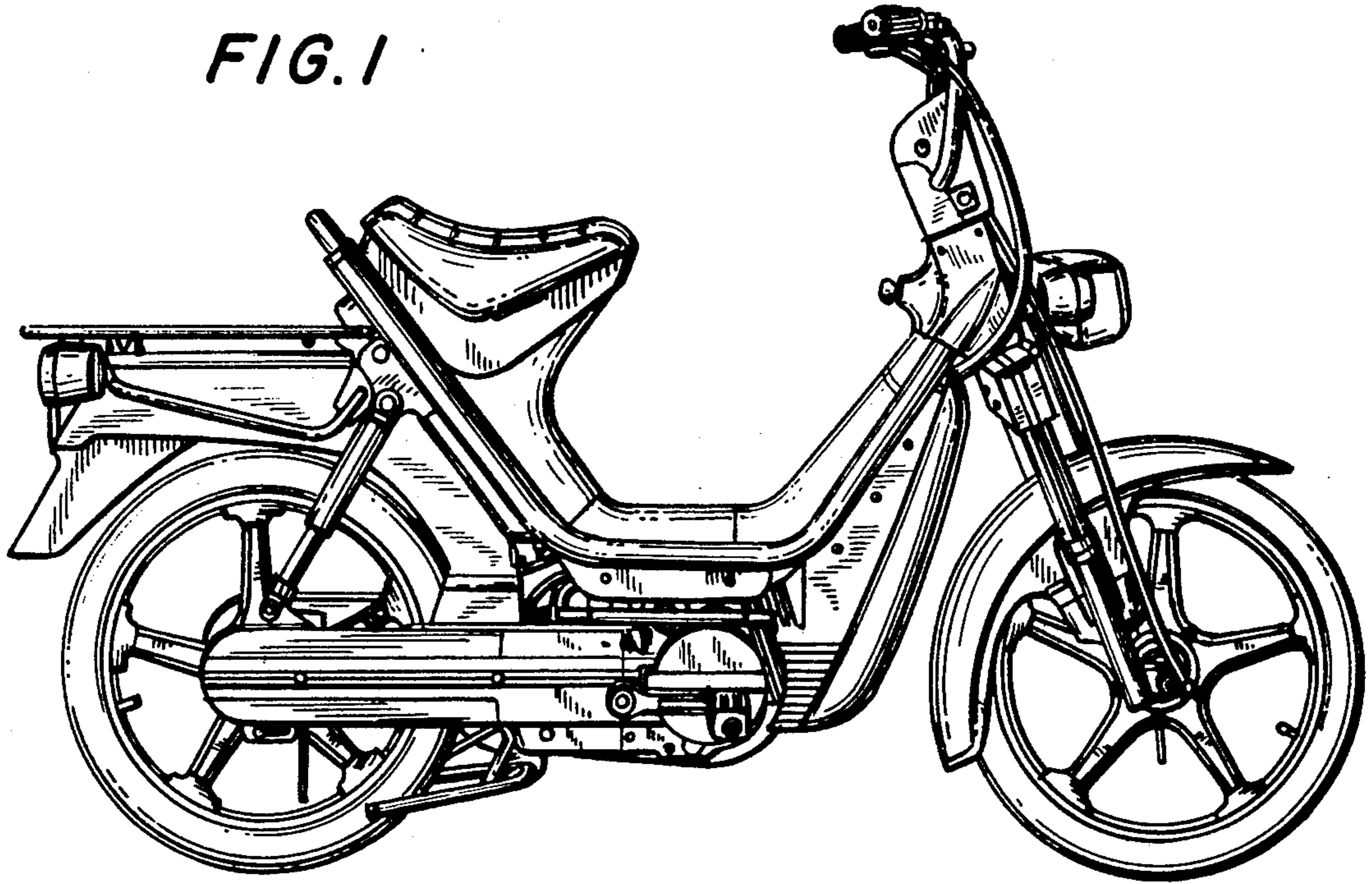

FIG. 2

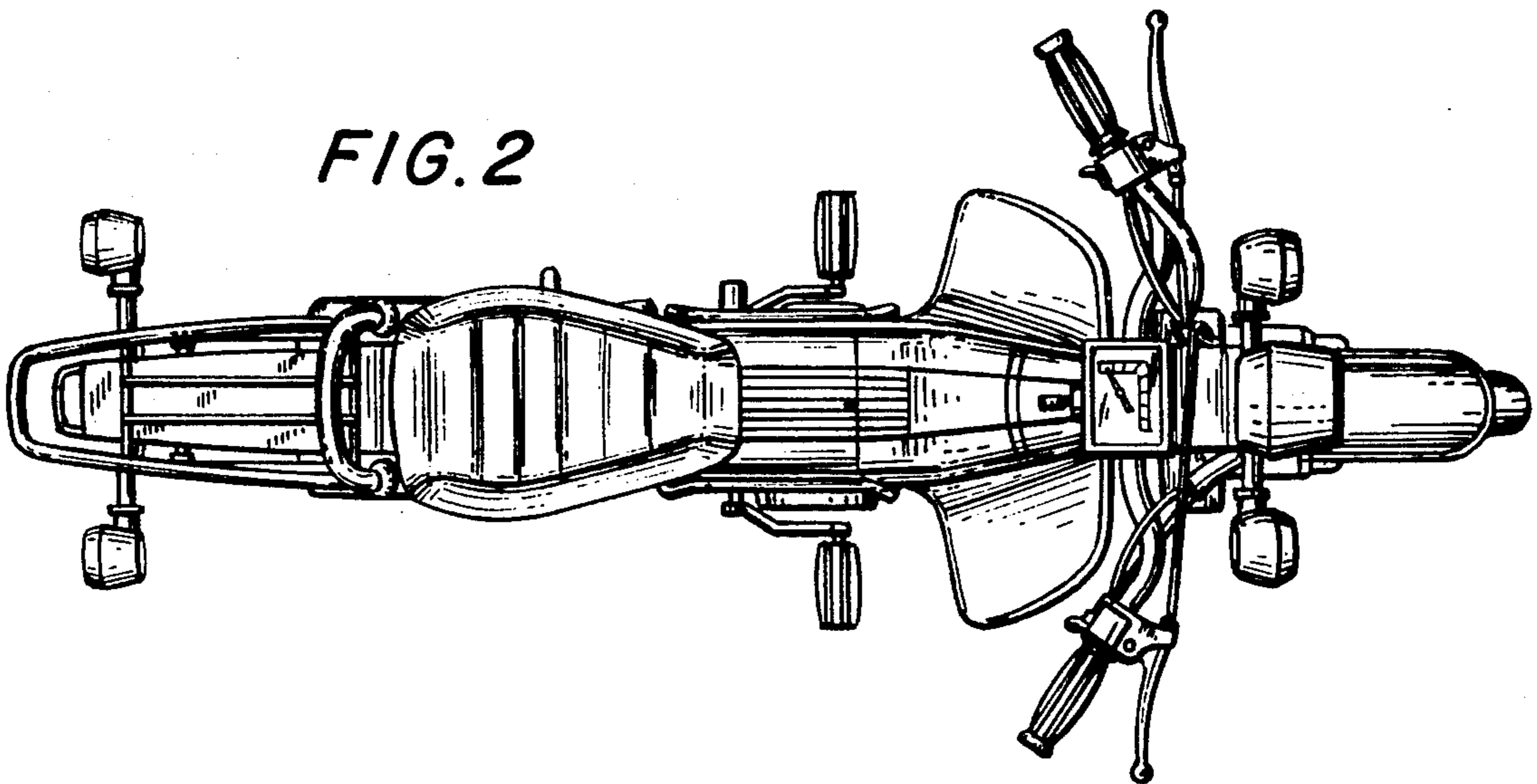

FIG. 3

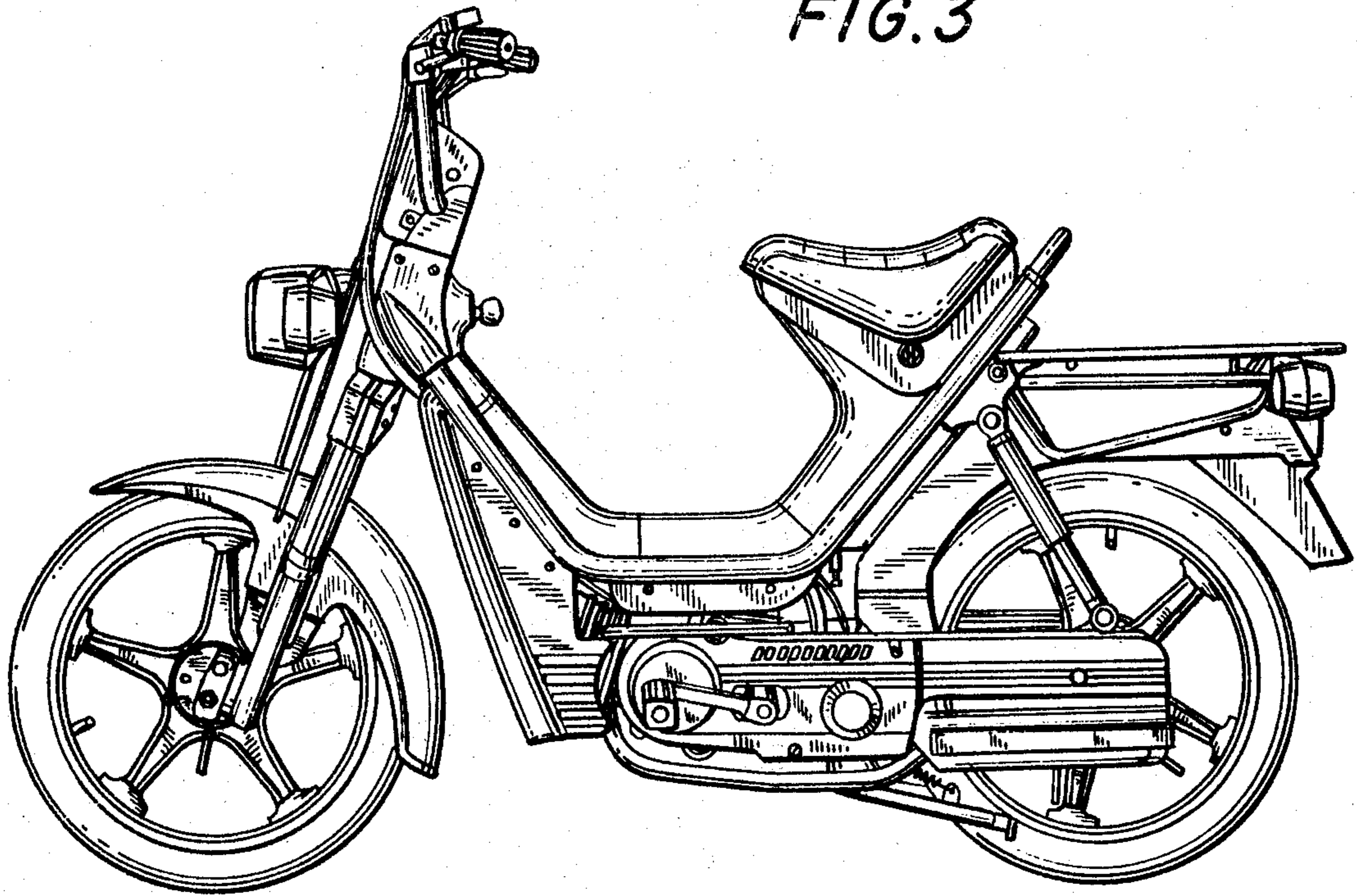

FIG. 4

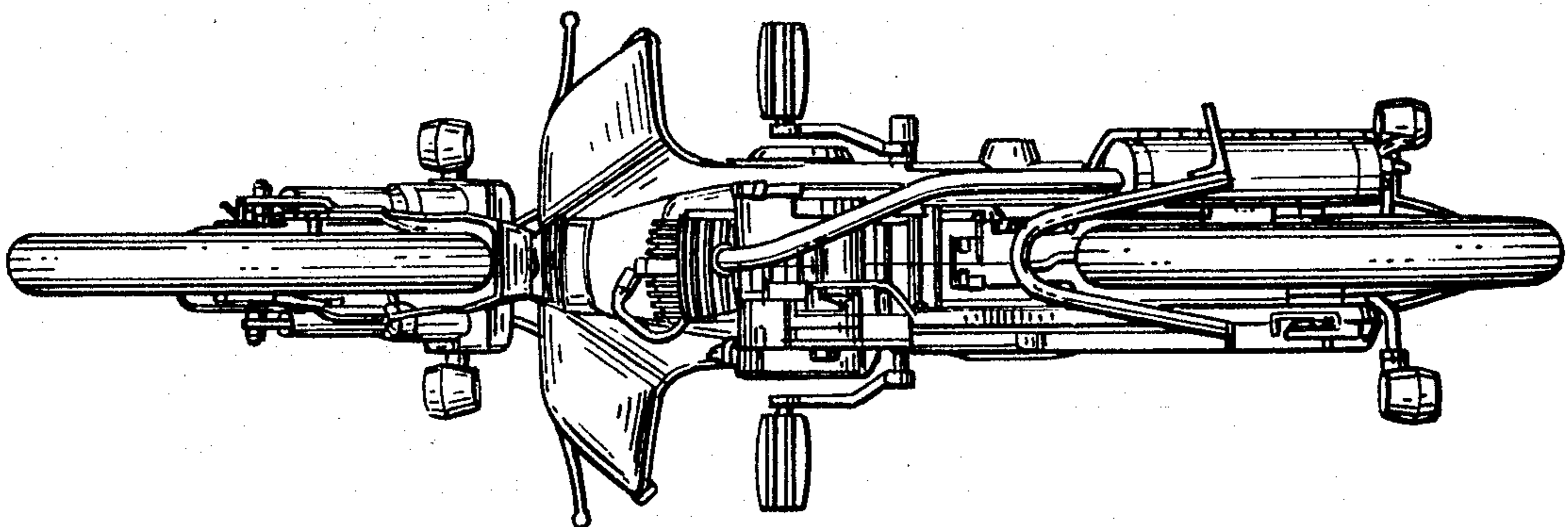

FIG. 5

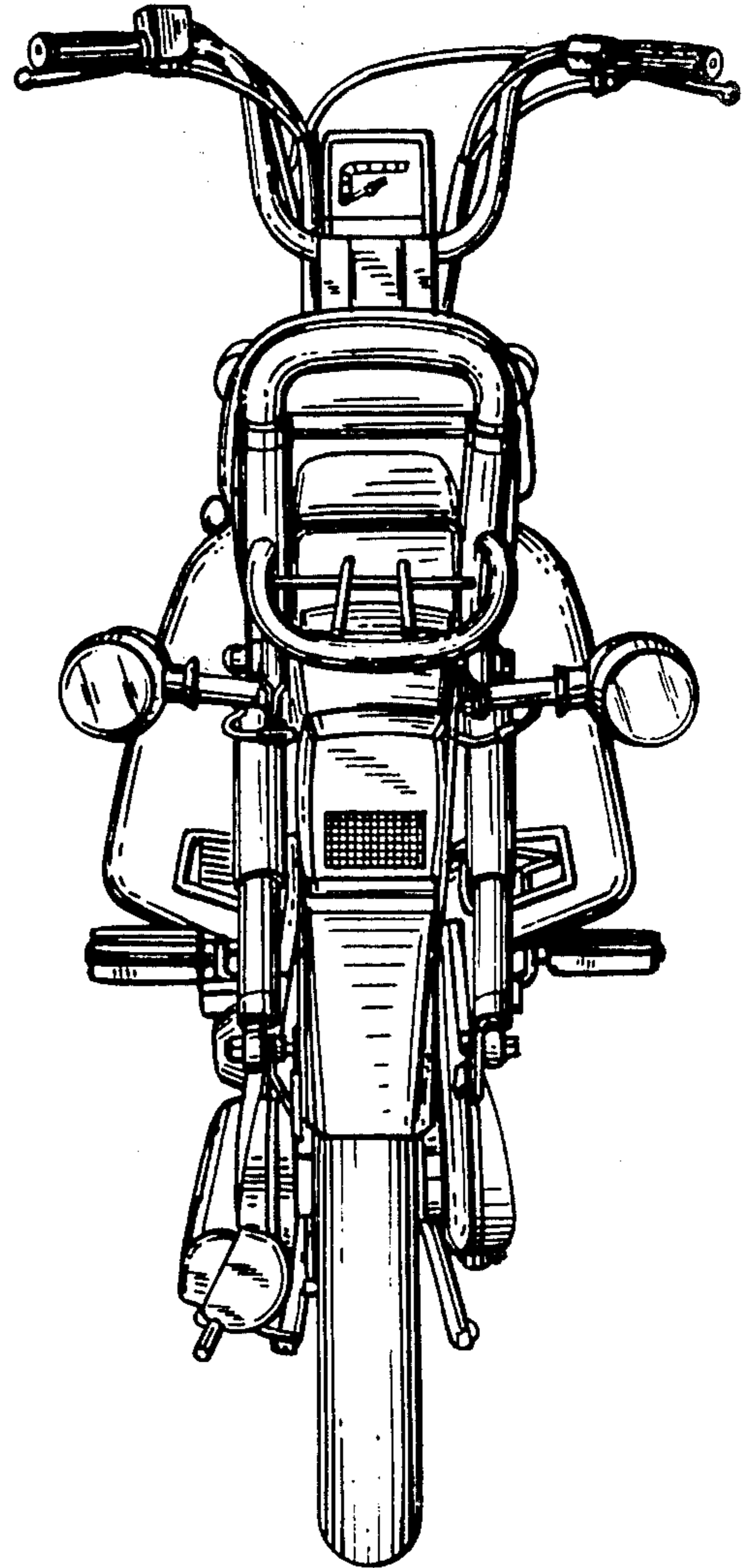
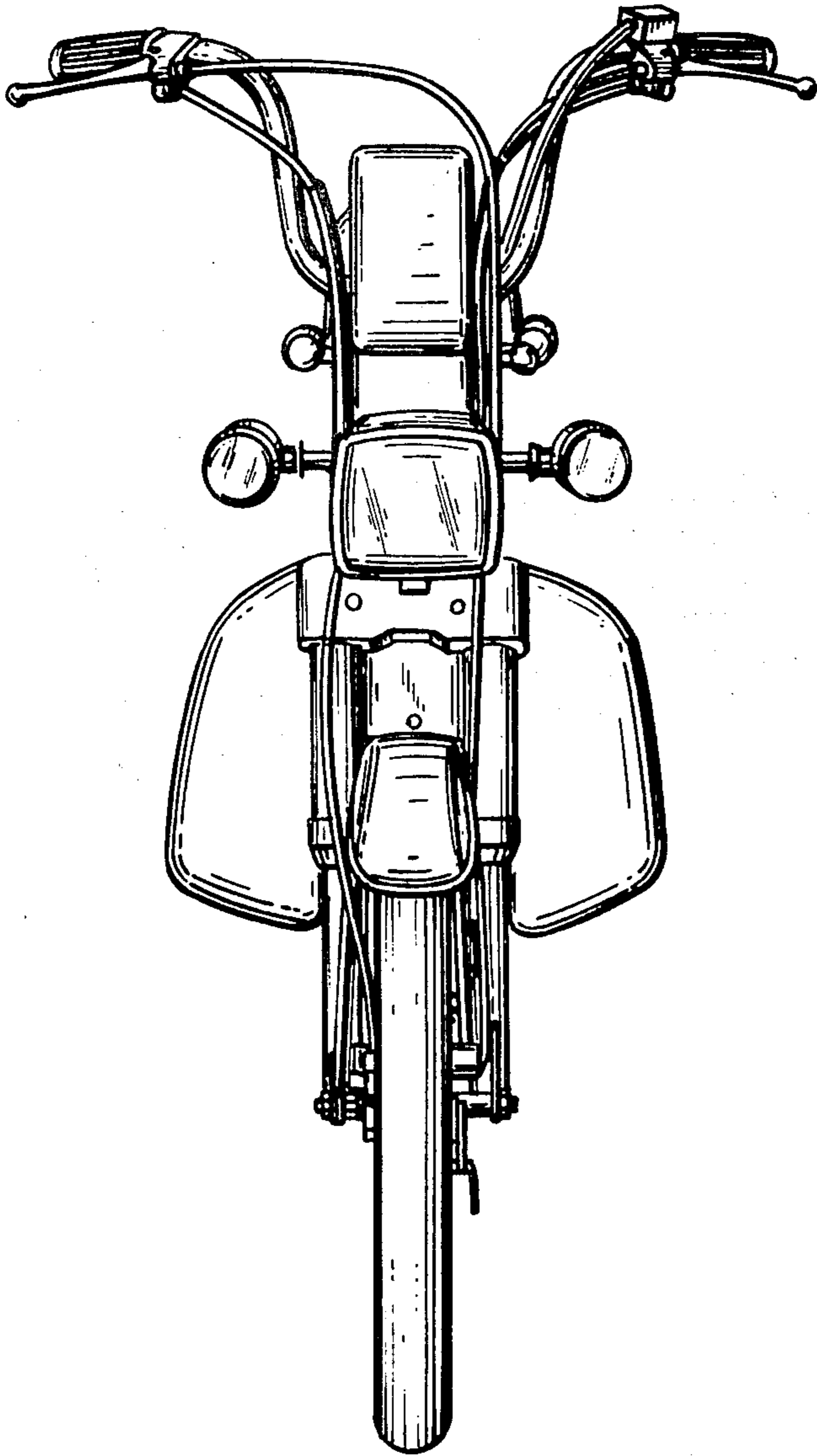

FIG. 6