

[54] COMBINED CONTROL PANEL AND RANGE HOOD FOR RECREATIONAL VEHICLES

[76] Inventor: Edwin F. Johnson, 1331 N. Lincoln Ave., Fullerton, Calif. 92631

[**] Term: 14 Years

[21] Appl. No.: 501,141

[22] Filed: Jun. 6, 1983

[52] U.S. Cl. D23/151

[58] Field of Search D23/83, 127, 139, 140, D23/149, 151; 98/115 R; 126/299 D, 299 R

[56] References Cited

U.S. PATENT DOCUMENTS

D. 157,296	2/1950	Sonntag	D23/151
D. 195,112	4/1963	Clark et al.	D23/151
D. 195,236	5/1963	Clark et al.	D23/151
D. 199,009	8/1964	Herman	D23/151
D. 208,513	9/1967	Rowald	D23/151
D. 237,971	12/1975	Chiang	D23/151
2,807,994	10/1957	Bernstein	D23/151 X
2,828,683	4/1958	Joseph et al.	126/299 R
2,888,871	6/1959	Fischer et al.	126/299 R
2,962,955	12/1960	Bernstein	D23/151 X
2,971,451	12/1961	Feig	126/299 D
3,075,335	1/1963	Bandlow	
3,233,606	2/1966	Turner et al.	126/299 D
3,690,245	9/1972	Ferlise et al.	126/299 D

OTHER PUBLICATIONS

Home Furnishings Daily, Feb. 13, 1962, p. 26, "upswept hood" item.

House & Home, Mar. 1959, p. 225, "1075 Series" item.

House & Home, Jan. 1960, p. 239, "New built-in oven hood" item.

Primary Examiner—James R. Largen

Attorney, Agent, or Firm—Harlan P. Huebner

[57] CLAIM

The ornamental design for combined control panel and range hood for recreational vehicles, substantially as shown and described.

DESCRIPTION

FIG. 1, is a perspective view of a combined control panel and range hood for recreational vehicles illustrating my new design;

FIG. 2, is a top plan view thereof;

FIG. 3, is a front elevational view thereof;

FIG. 4, is a left end elevational view thereof;

FIG. 5, is a right end elevational view thereof;

FIG. 6, is a bottom plan view thereof;

FIG. 7, is a rear elevational view thereof;

FIG. 8 is a perspective view of a modified form of the combined control panel and range hood for recreational vehicles shown in FIG. 1; and

FIG. 9 is a perspective view of a second modified form of the combined control panel and range hood for recreational vehicles shown in FIG. 1.

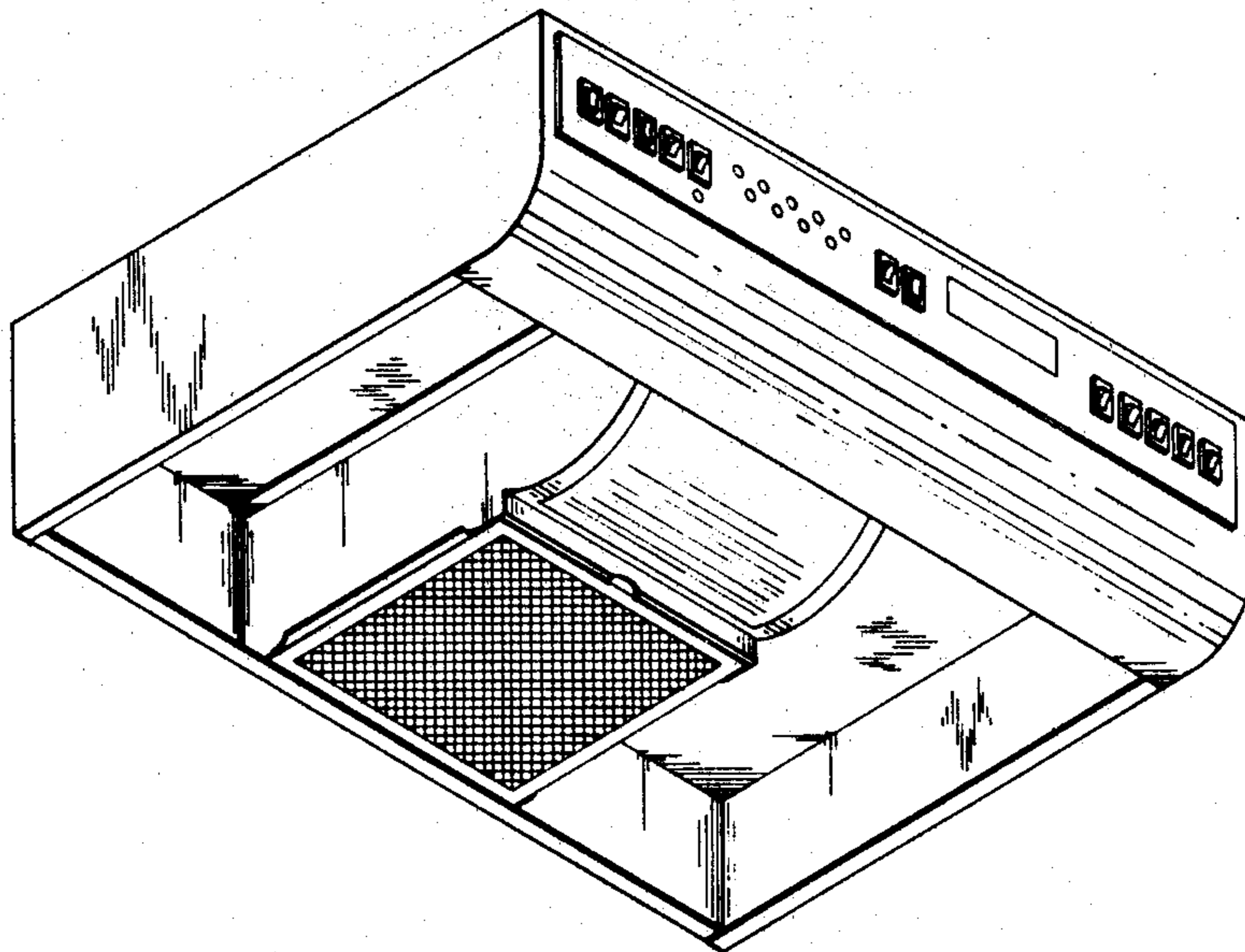

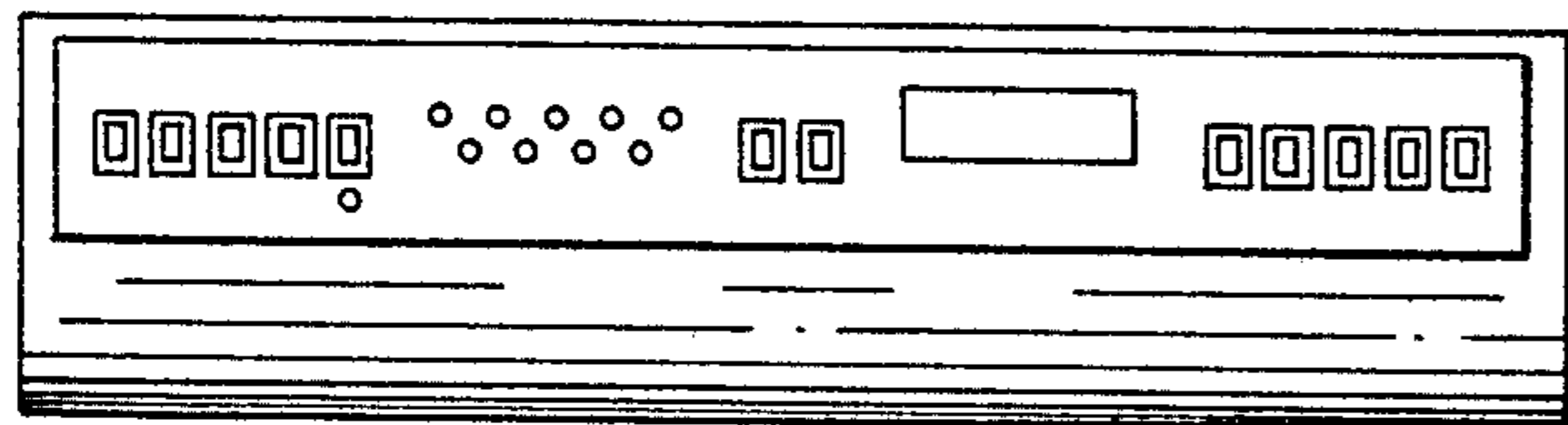
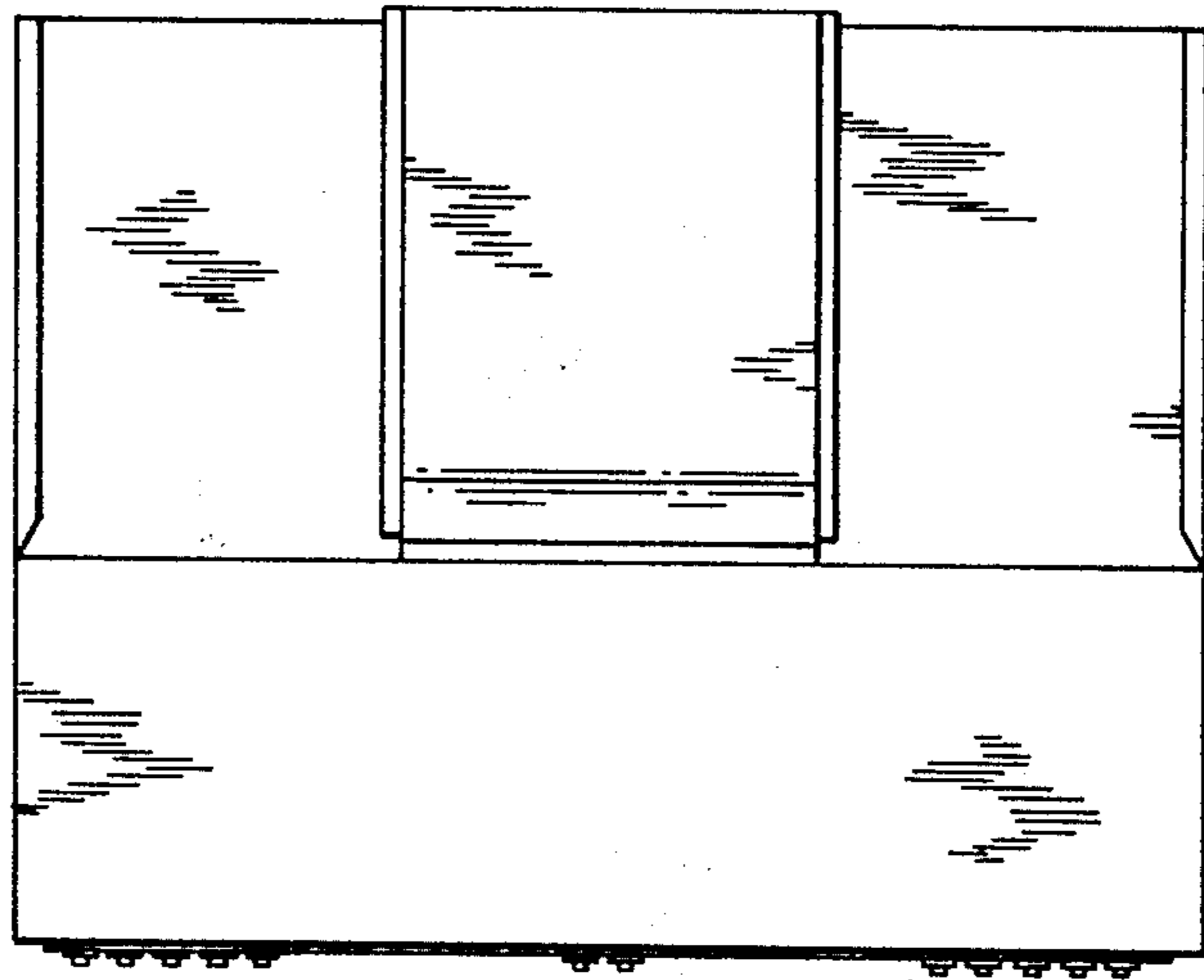
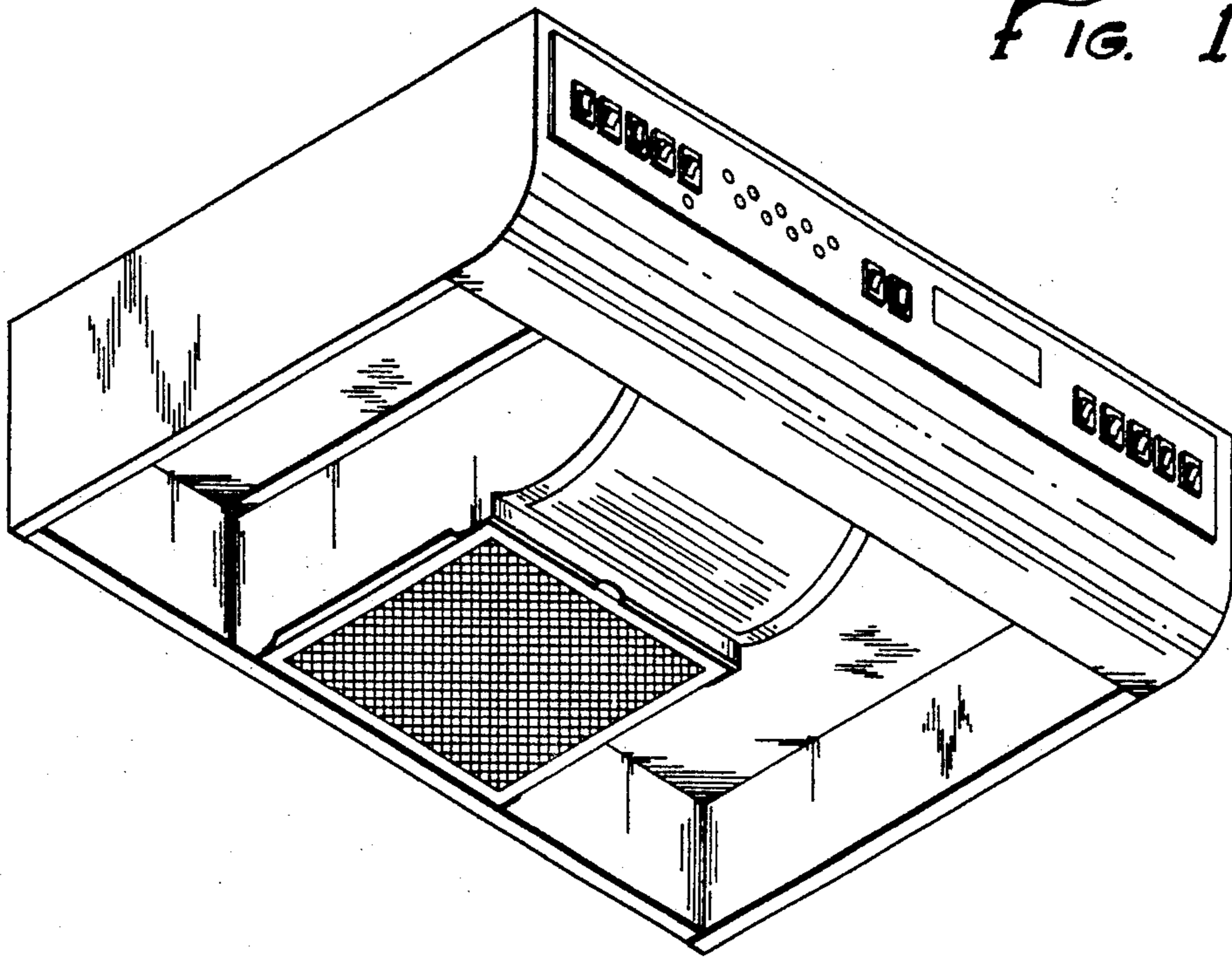

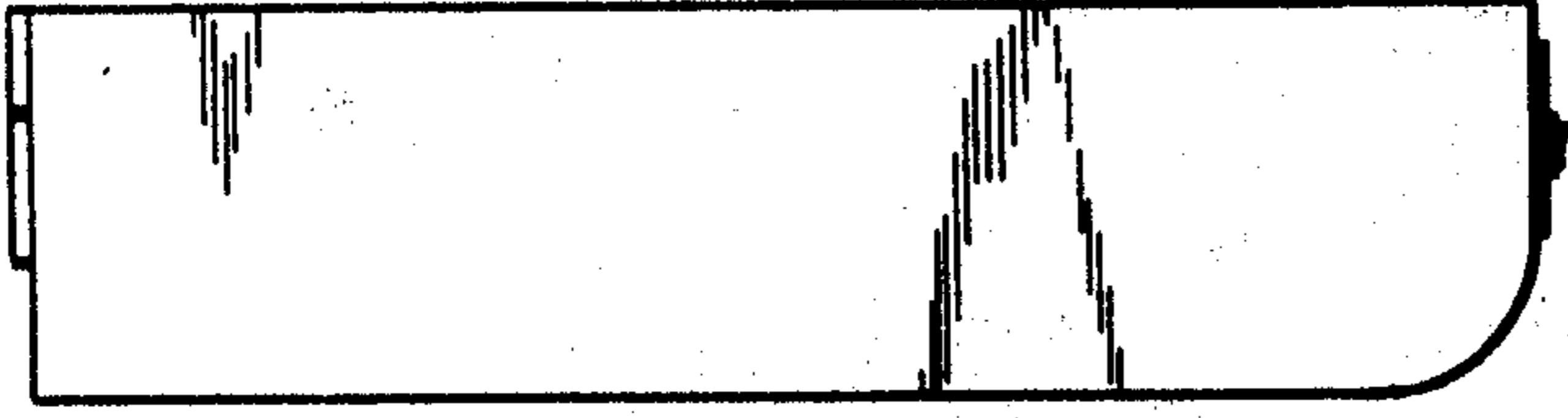

FIG. 4.



FIG. 5.

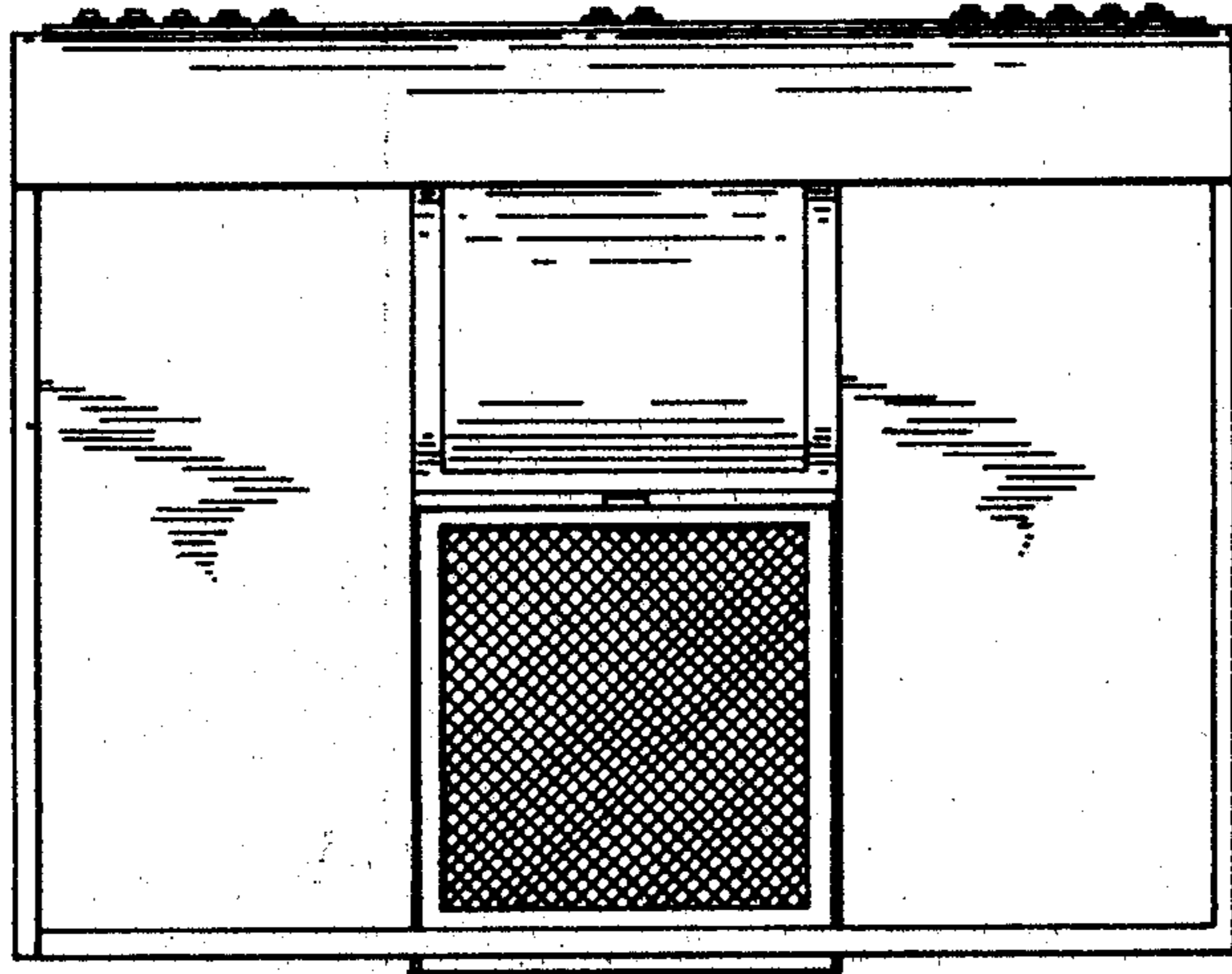

FIG. 6.

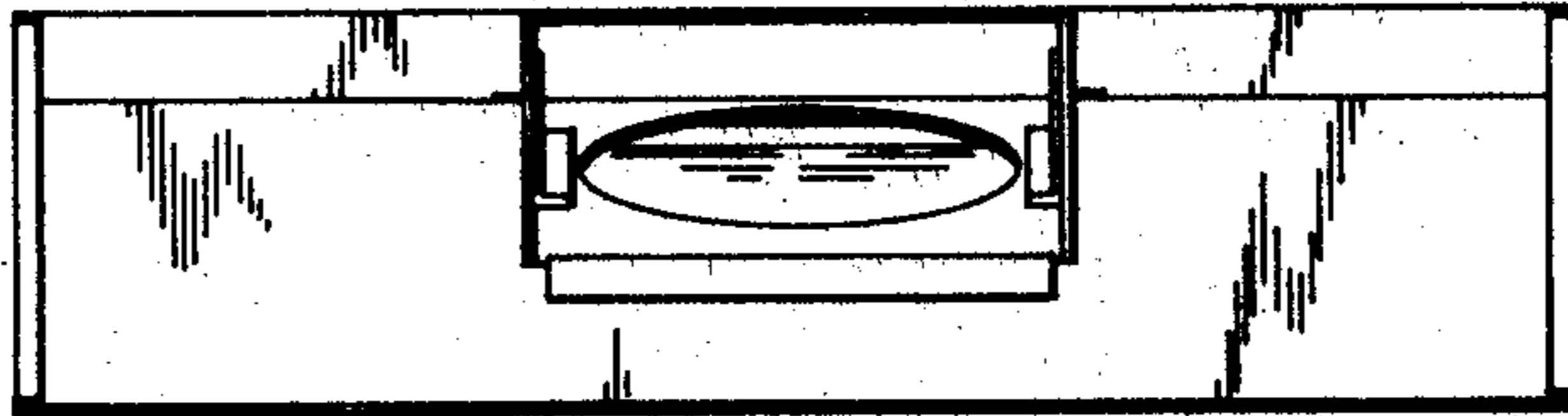

FIG. 7.

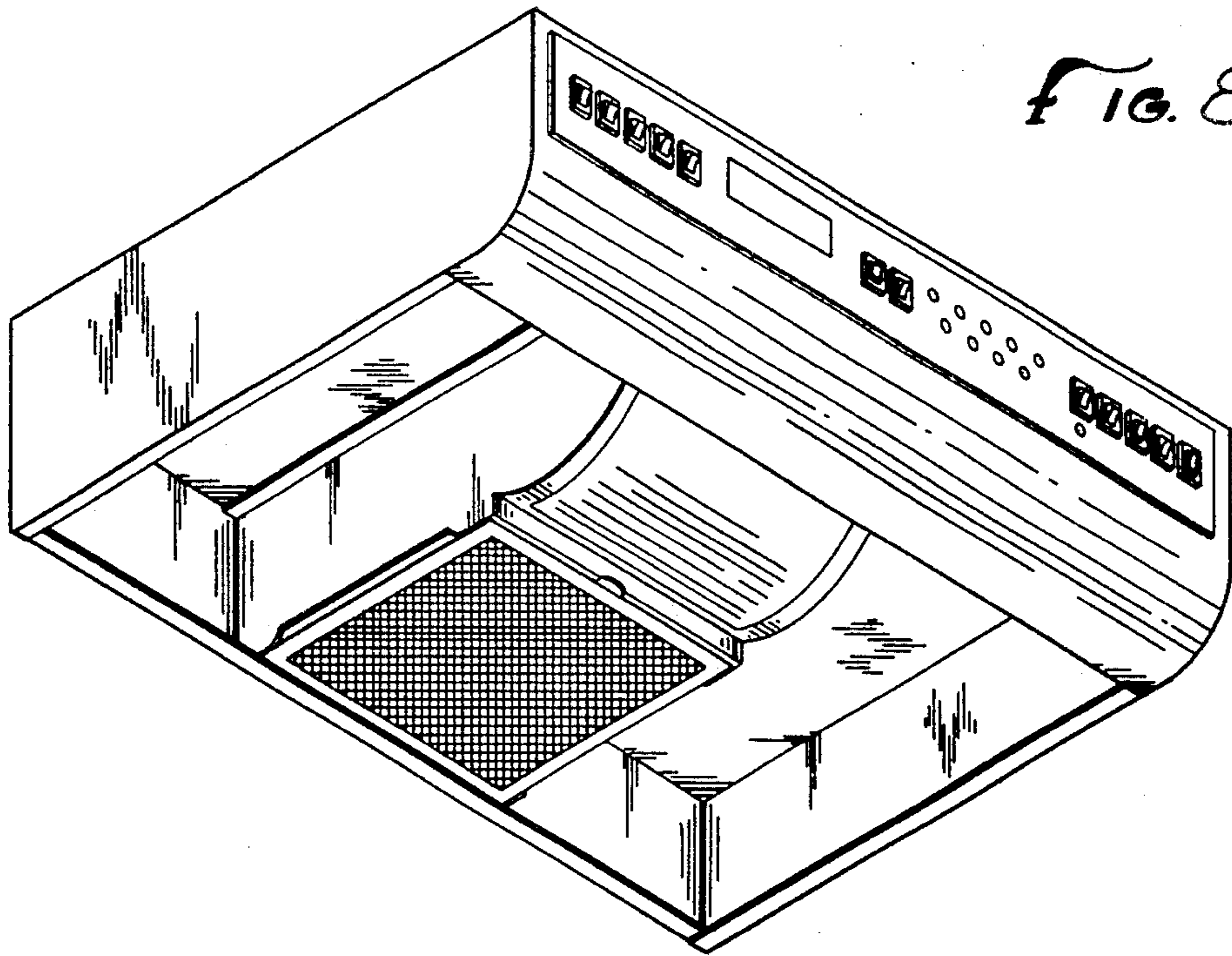

FIG. 8.

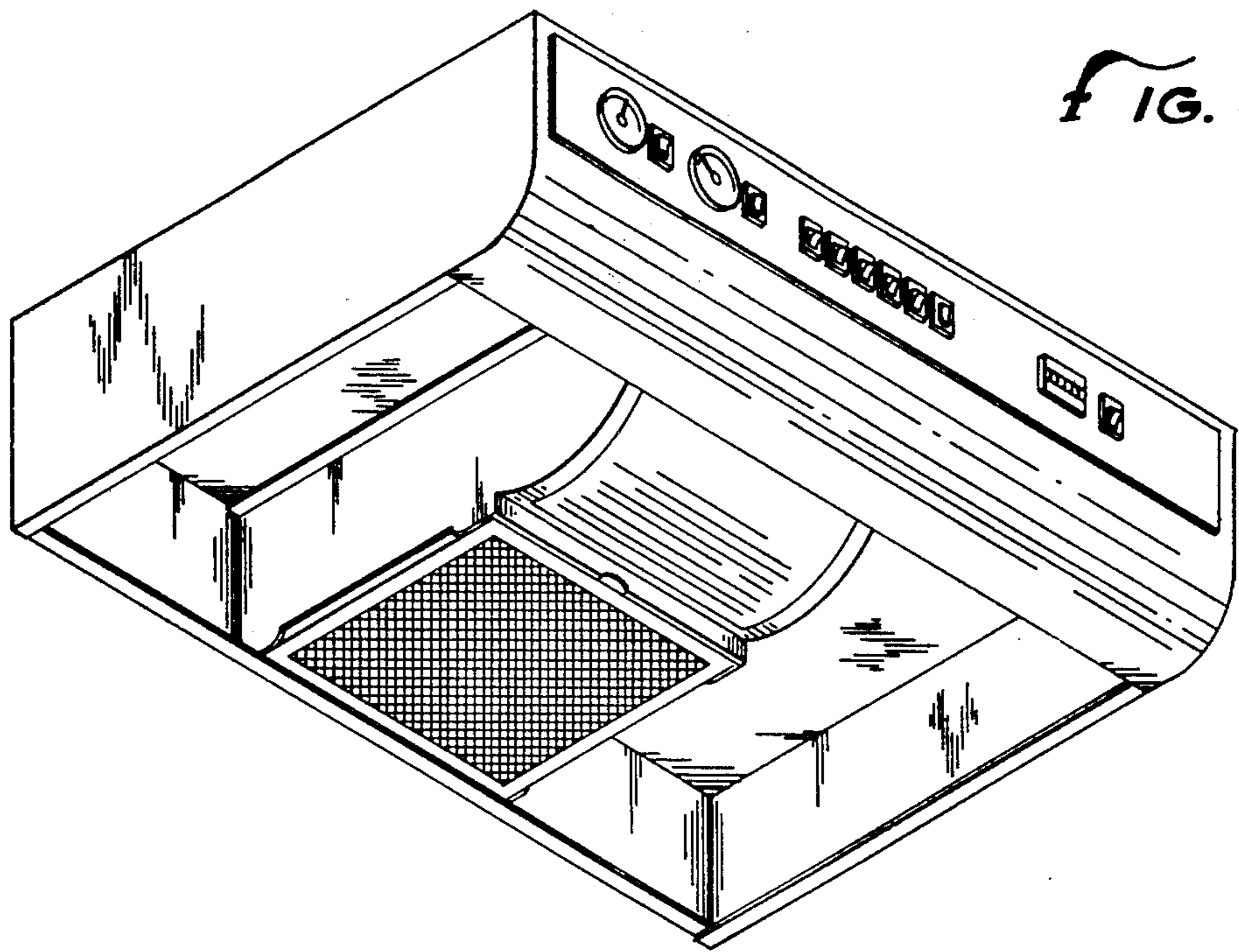

FIG. 9.

UNITED STATES PATENT AND TRADEMARK OFFICE
CERTIFICATE OF CORRECTION

PATENT NO. : Des. 274,934
DATED : July 31, 1984
INVENTOR(S) : Edwin F. Johnson

It is certified that error appears in the above-identified patent and that said Letters Patent is hereby corrected as shown below:

On the title page insert:

-- 73/ Assignee: Jensen General Corp.
Los Angeles, California --.

Signed and Sealed this

Eighteenth Day of December 1984

[SEAL]

Attest:

Attesting Officer

GERALD J. MOSSINGHOFF

Commissioner of Patents and Trademarks