

[54] MOTOR CYCLE WHEEL

[75] Inventor: Ketaro Ito, Tokyo, Japan

[73] Assignee: Honda Giken Kogyo Kabushiki Kaisha, Tokyo, Japan

[**] Term: 14 Years

[21] Appl. No.: 352,972

[22] Filed: Feb. 26, 1982

[30] Foreign Application Priority Data

Sep. 2, 1981 [JP] Japan 56-38779
[52] U.S. Cl. D12/211; D12/205
[58] Field of Search D12/205, 209, 211;
301/63 R, 64 R, 64 SD, 65, 66, 73

[56] References Cited

U.S. PATENT DOCUMENTS
153,207 7/1874 Weaver 301/66
D. 258,503 3/1981 Semple D12/211

FOREIGN PATENT DOCUMENTS

924811 3/1947 France 301/73
176178 of 1922 United Kingdom 301/64 R

Primary Examiner—James M. Gandy
Attorney, Agent, or Firm—Sughrue, Mion, Zinn,
Macpeak and Seas

[57] CLAIM

The ornamental design for a motor cycle wheel, as shown and described.

DESCRIPTION

FIG. 1 is a perspective view of a motor cycle wheel showing my new design, the wheel being symmetrical about its axis;
FIG. 2 is a bottom plan view thereof;
FIG. 3 is a top plan view thereof;
FIG. 4 is a side elevational view thereof taken from the side opposite that shown in FIG. 1; and
FIG. 5 is a side elevational view thereof opposite to that of FIG. 4.

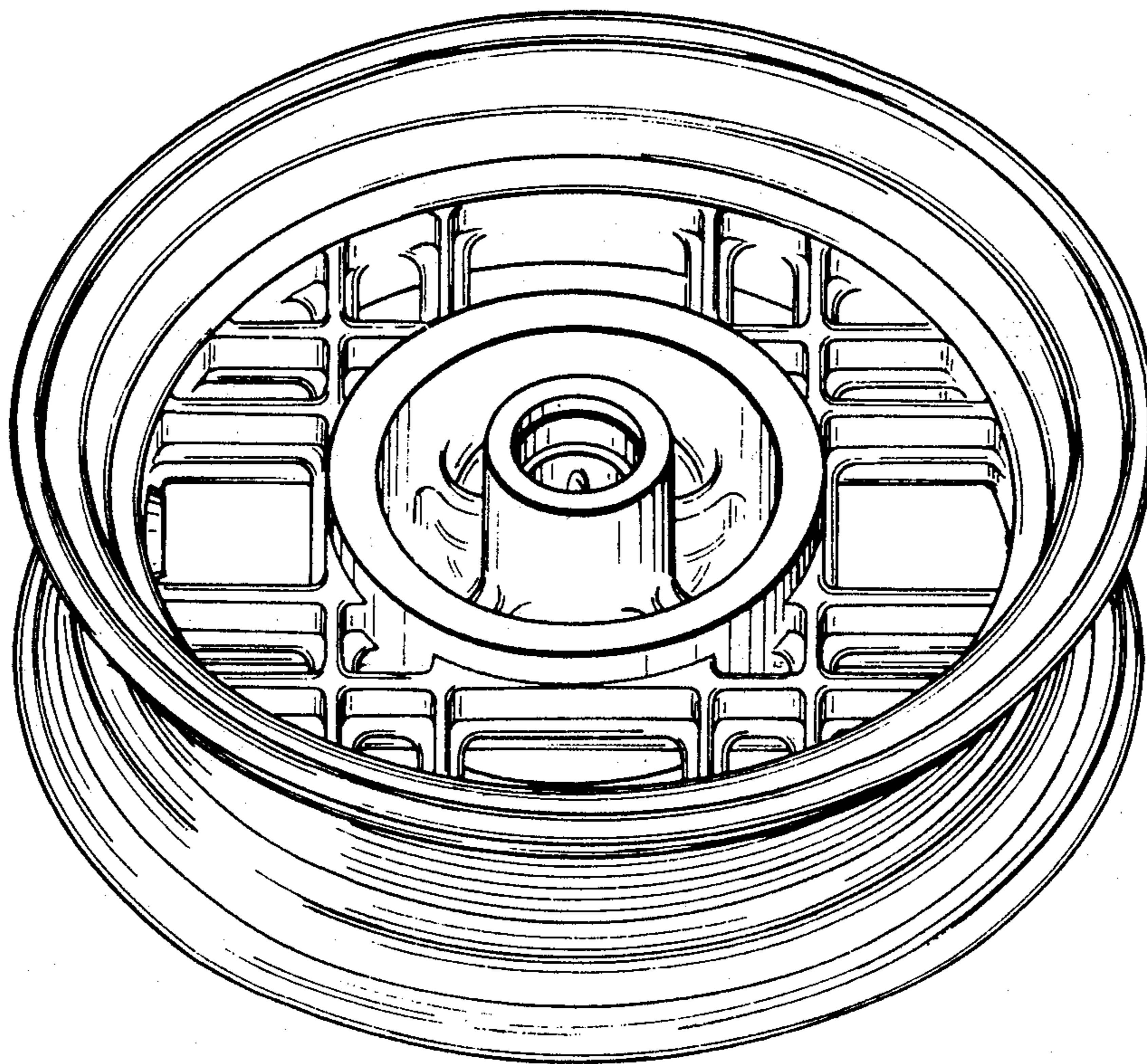

FIG. 3

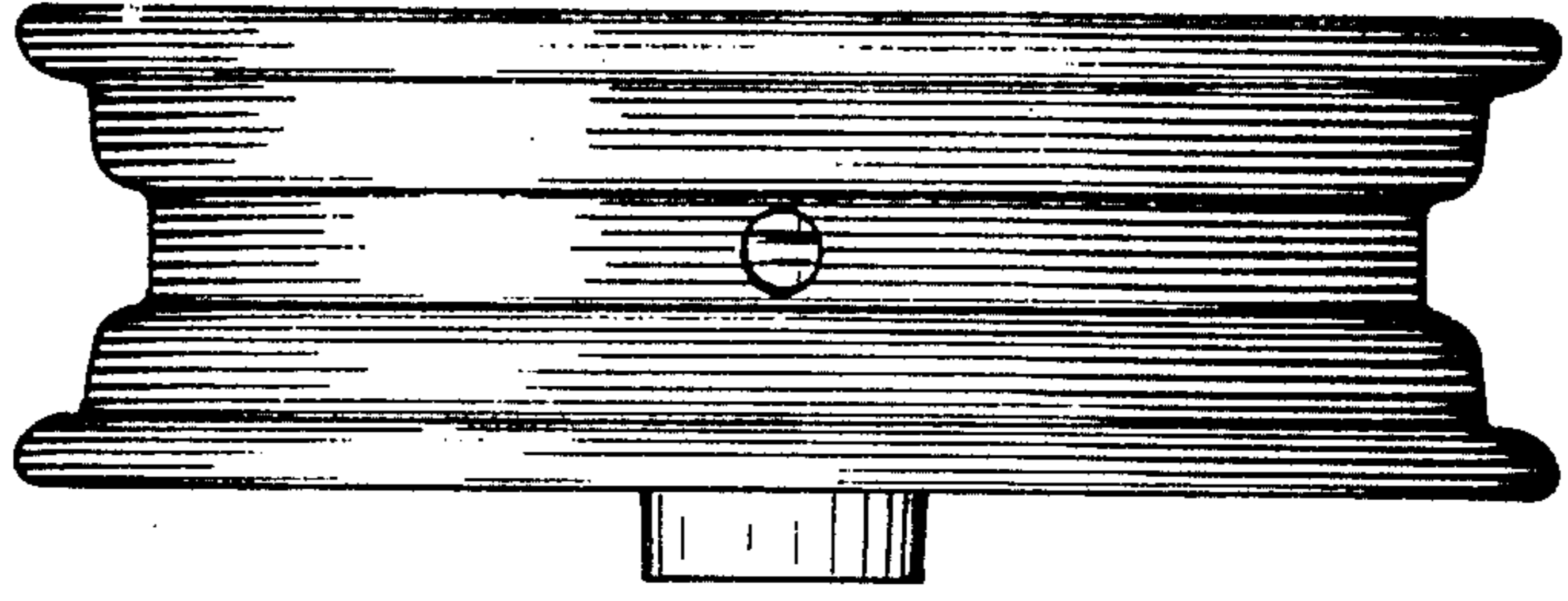

FIG. 2

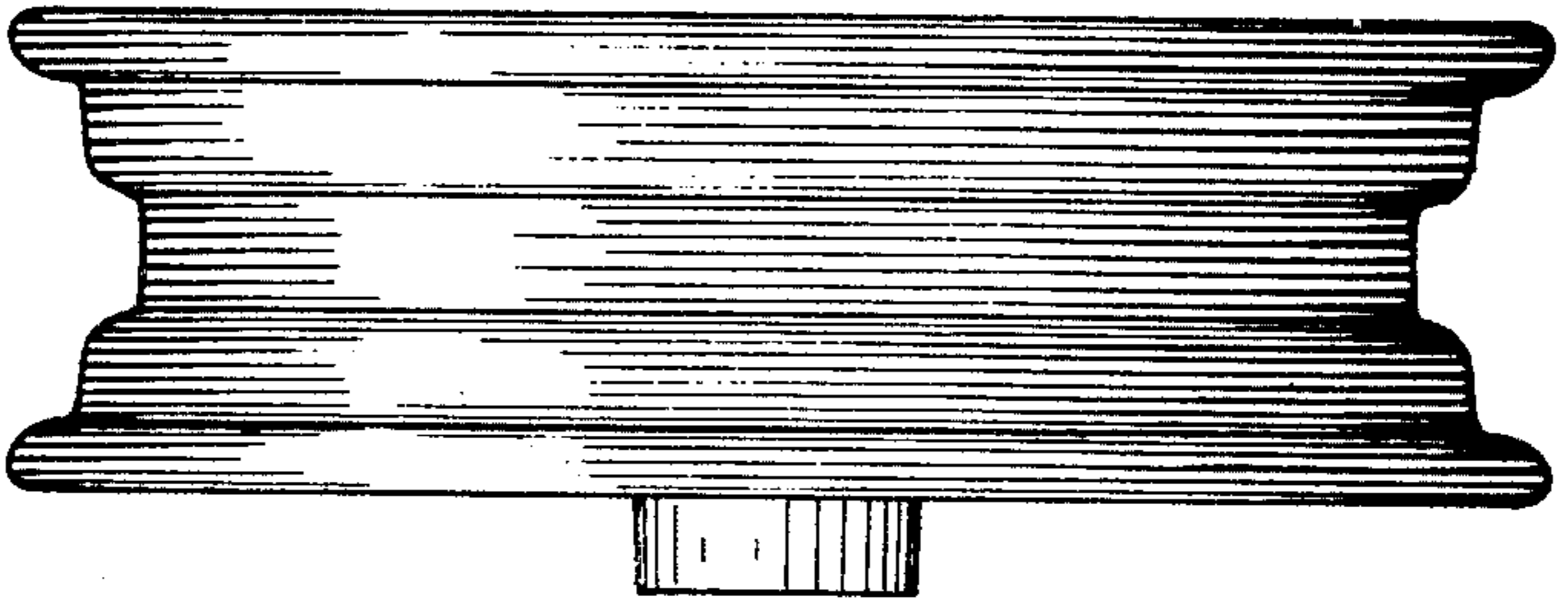

FIG. 1

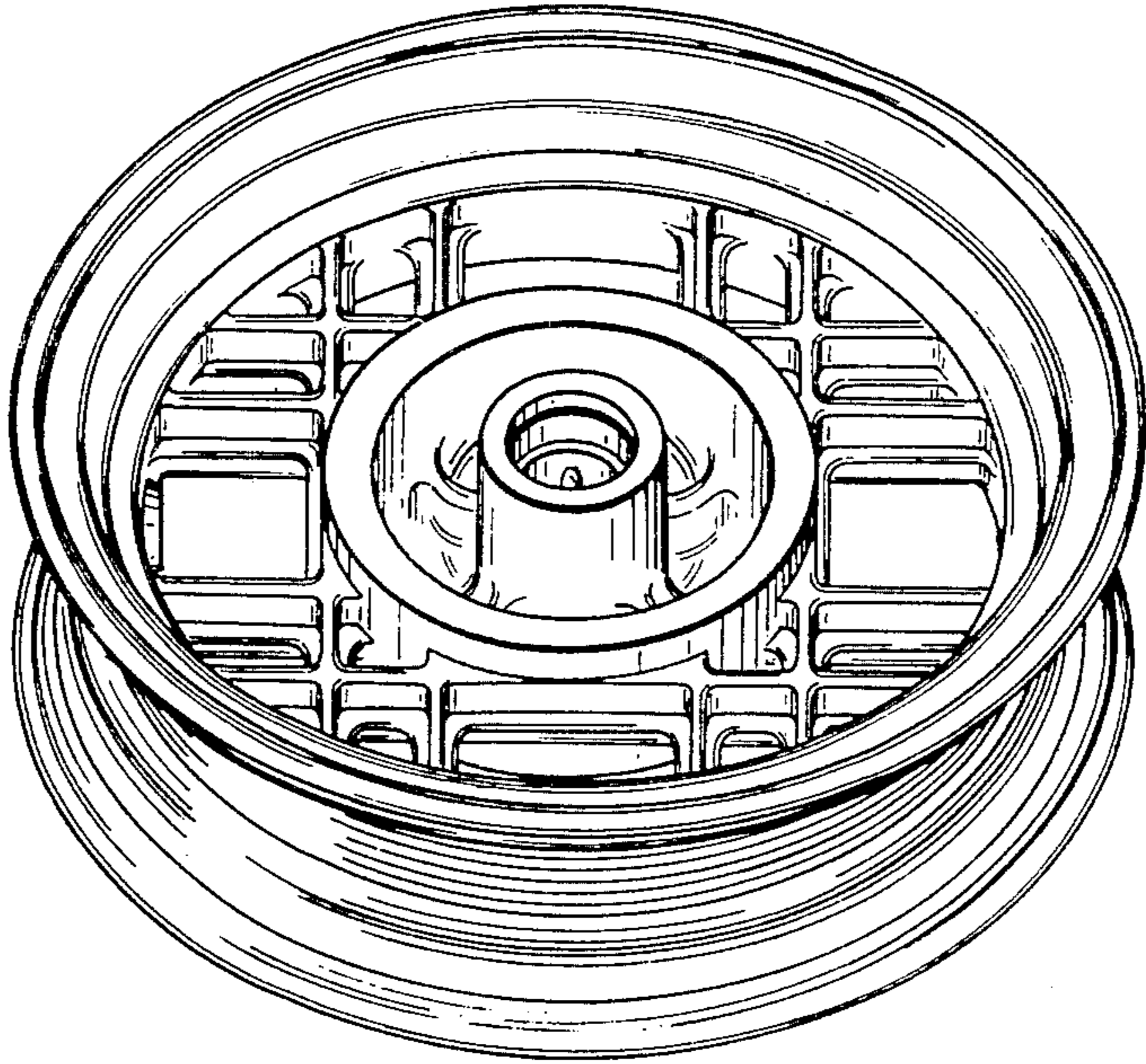

FIG. 5

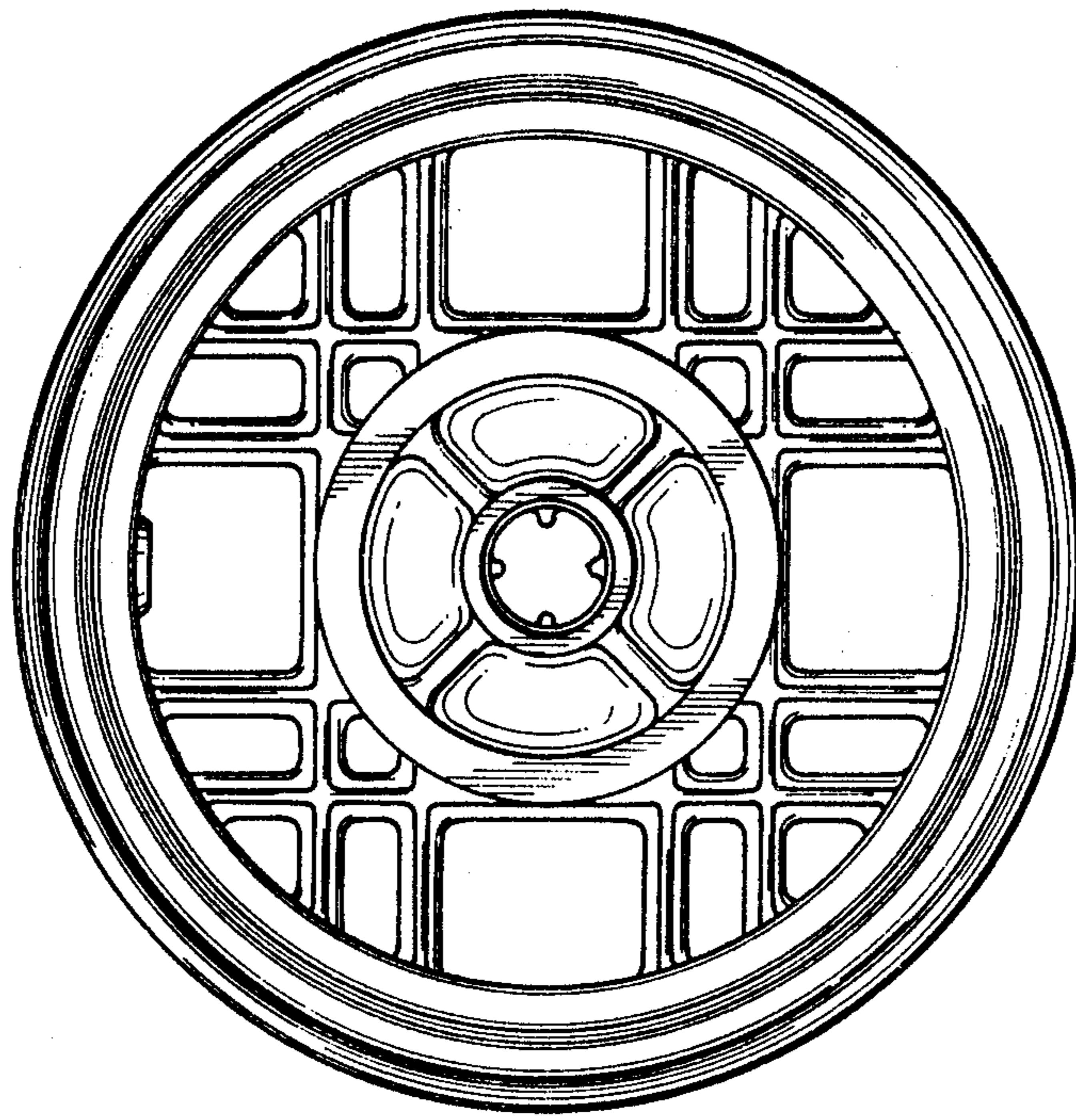

FIG. 4

