

[54] COMBINED HEAD LAMP AND BATTERY PACK THEREFOR

[76] Inventor: Shiu Shing, 3A Hammer Hill Rd., G/F, Kowloon, Hong Kong

[**] Term: 14 Years

[21] Appl. No.: 286,759

[22] Filed: Jul. 27, 1981

[30] Foreign Application Priority Data

Apr. 28, 1981 [GB] United Kingdom 1000197
 [52] U.S. Cl. D26/39
 [58] Field of Search D26/24, 37-50;
 362/103, 105, 106, 154, 156, 157, 158, 183, 184,
 186-208; 128/23

[56] References Cited

U.S. PATENT DOCUMENTS

3,069,538 12/1962 Hobson 362/105
 3,912,919 10/1975 Eriksson 128/23 X

Primary Examiner—Susan J. Lucas
 Attorney, Agent, or Firm—Wenderoth, Lind & Ponack

[57] CLAIM

The ornamental design for combined head lamp and battery pack therefor, substantially as shown.

DESCRIPTION

FIG. 1 is a front perspective view from below of a combined head lamp and battery pack therefor showing my new design;
 FIG. 2 is a rear perspective view thereof from above;
 FIG. 3 is a top plan view thereof; and
 FIG. 4 is a side elevational view thereof.

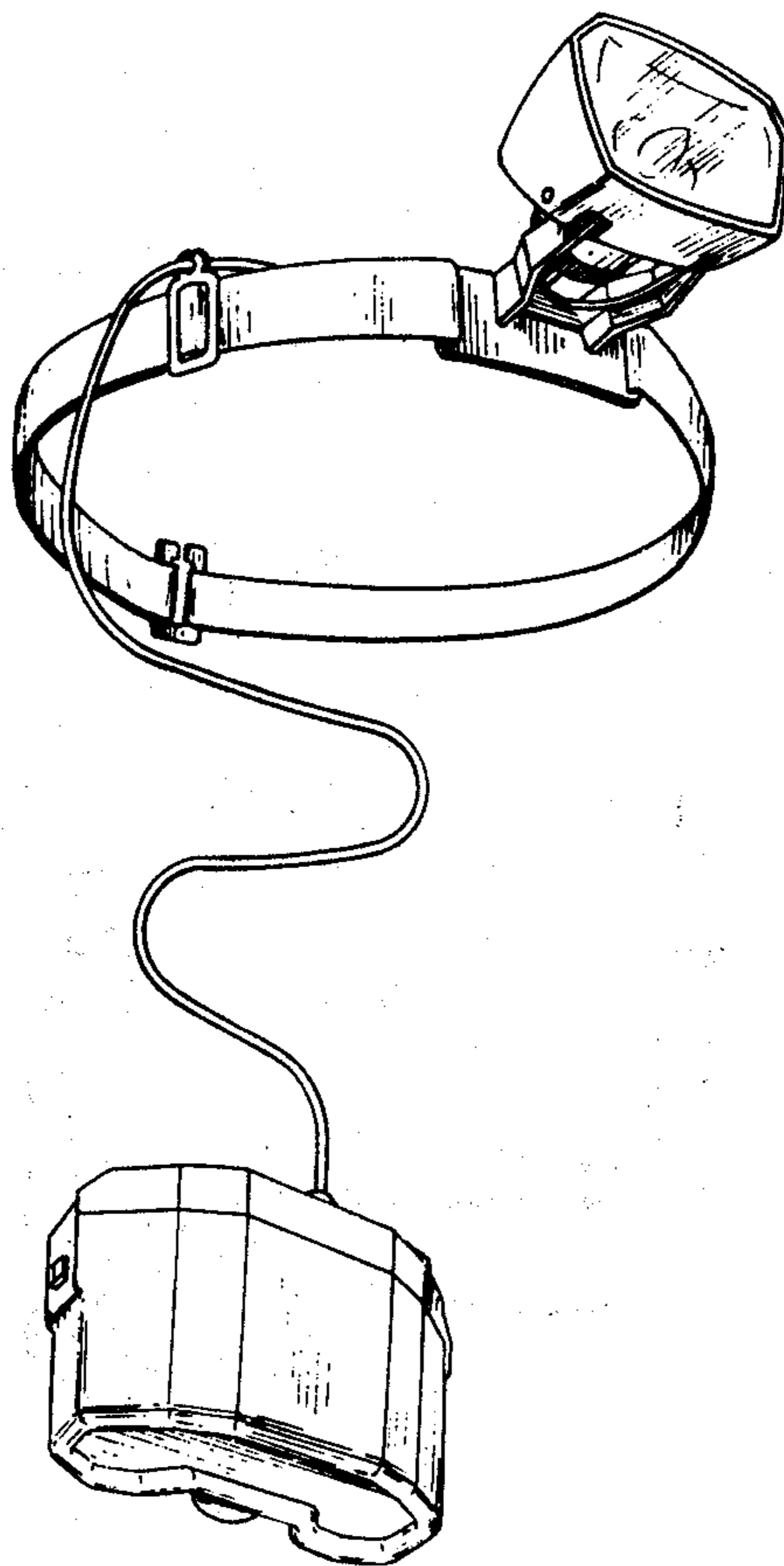

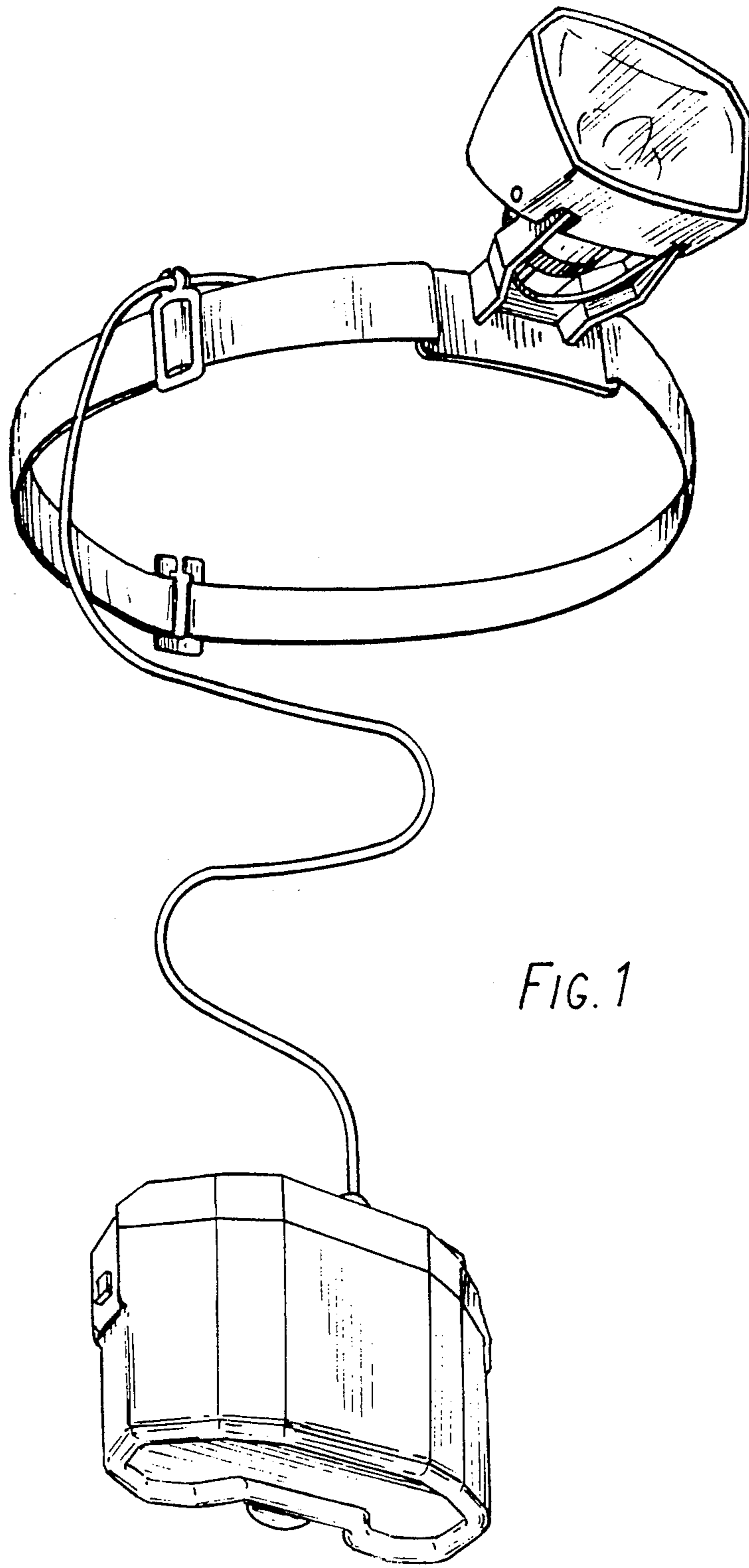

FIG. 1

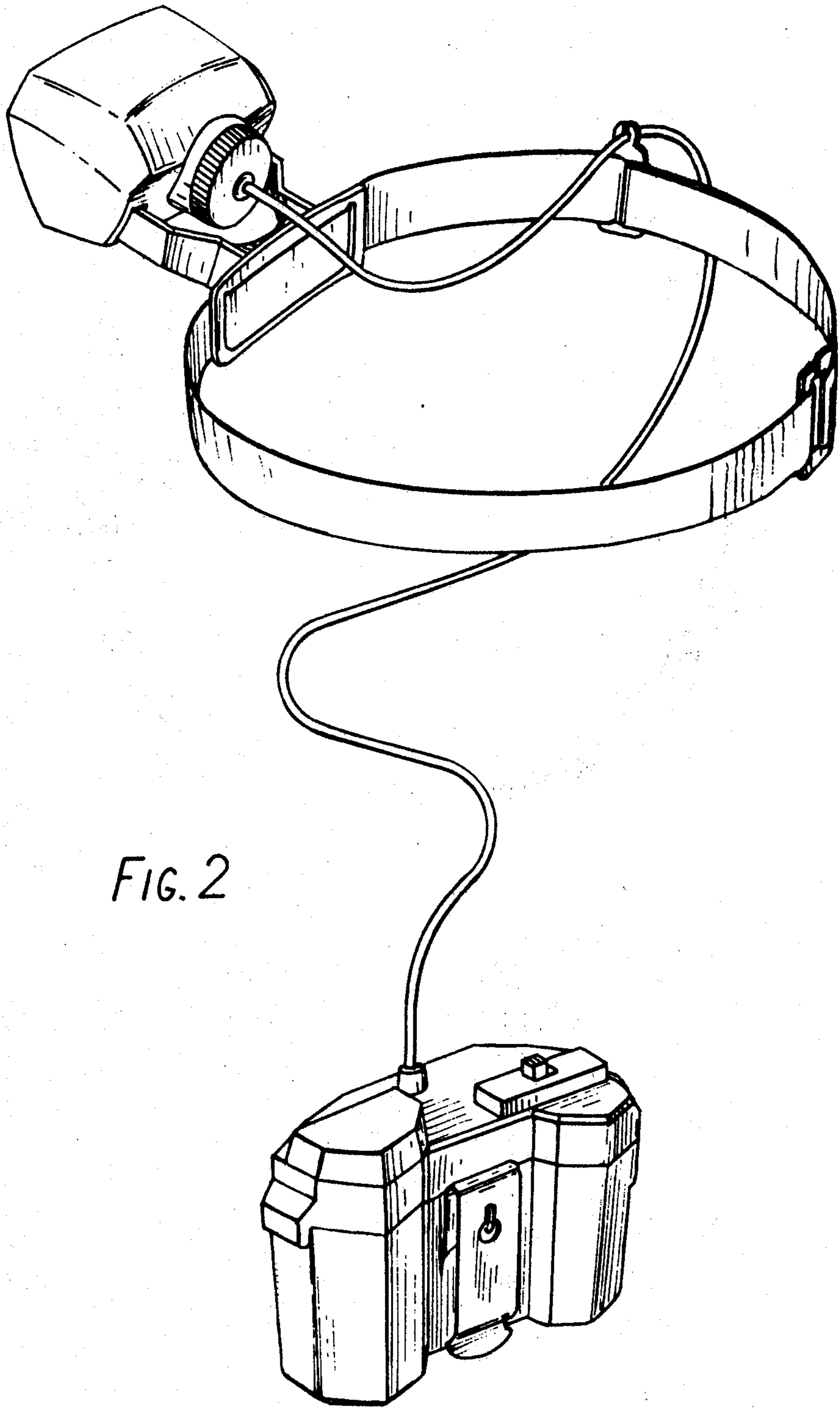

FIG. 2

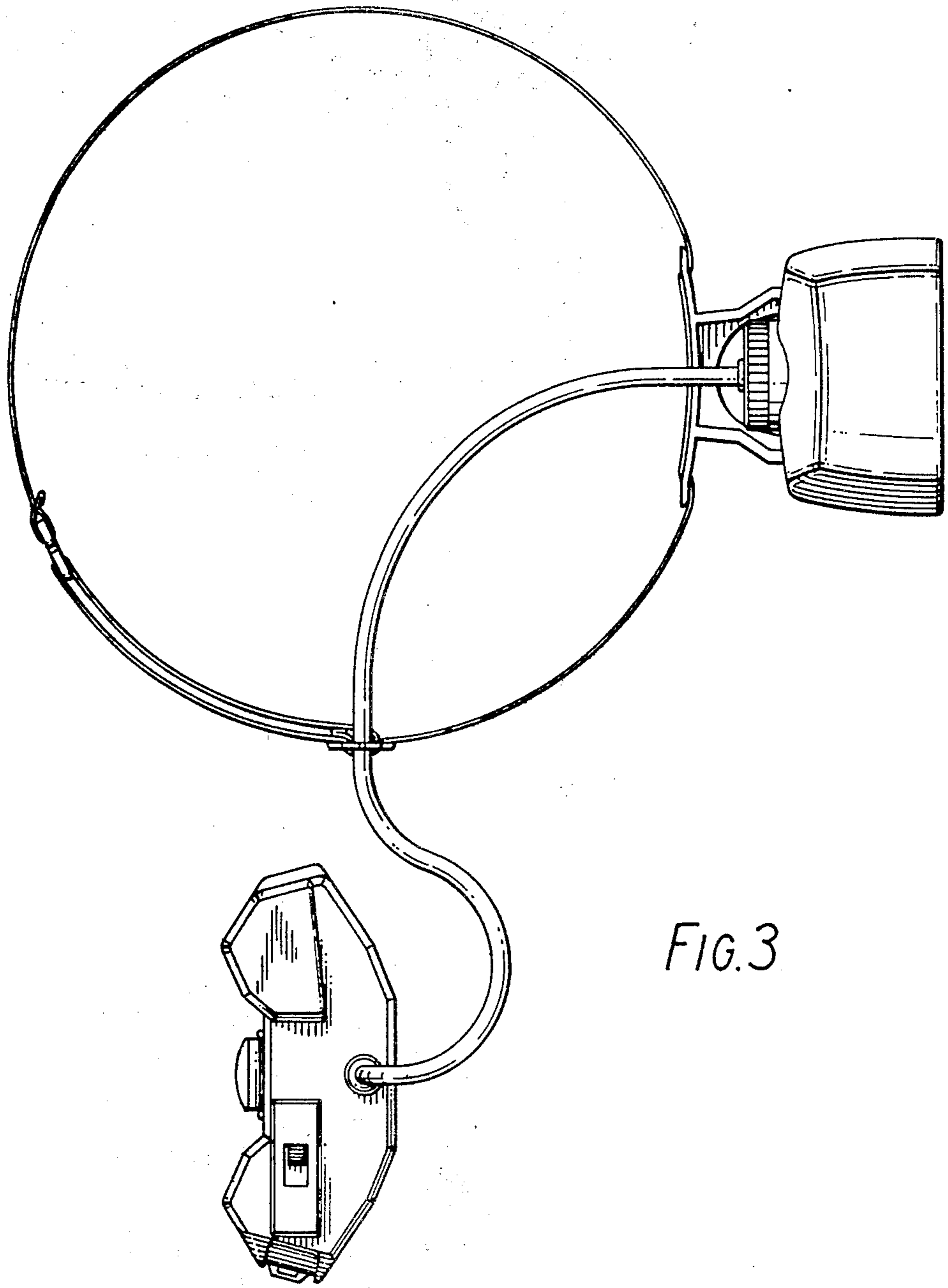

FIG. 3

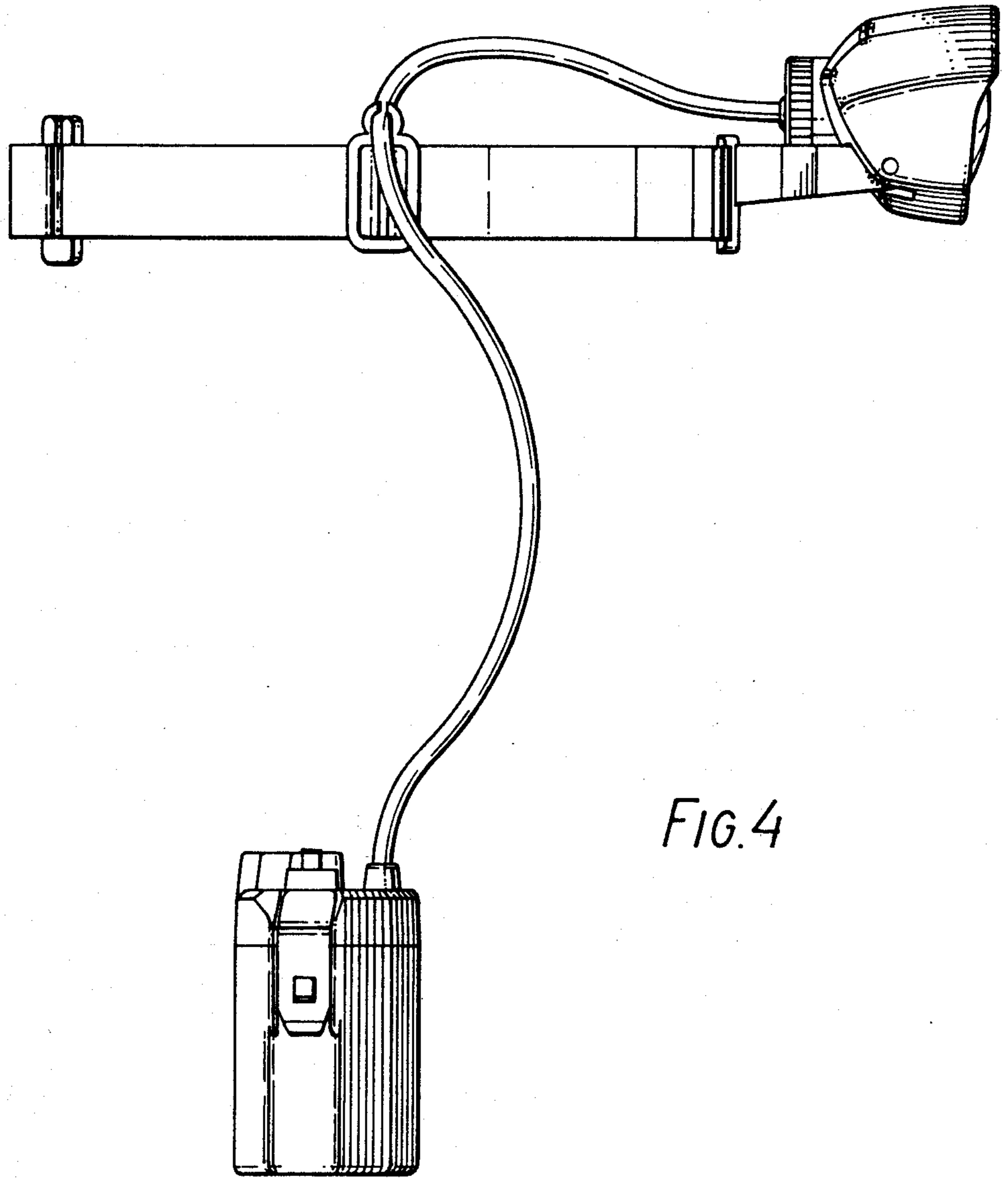

FIG. 4