

[54] SOLID BODY ACOUSTIC GUITAR

[76] Inventor: John Caruth, 1320 Chesterton, Richardson, Tex. 75080

[**] Term: 14 Years

[21] Appl. No.: 269,398

[22] Filed: Jun. 1, 1981

[52] U.S. Cl. D17/19

[58] Field of Search D17/14, 19, 20; 84/267, 84/291; 84/269-271

[56] References Cited

U.S. PATENT DOCUMENTS

D. 62,165	4/1923	Gerl	84/291
D. 71,589	12/1926	Kraus	D17/19
D. 225,275	11/1972	Owens	D17/19
1,069,987	8/1913	Taylor et al.	84/269
1,649,101	11/1927	Dopyera	84/271

Primary Examiner—Jane E. Corrigan

Attorney, Agent, or Firm—Thomas L. Crisman; Stanley R. Moore

[57] CLAIM

The ornamental design for the solid body acoustic guitar, as shown and described.

DESCRIPTION

FIG. 1 is a front, bottom and left side perspective view of a solid body acoustic guitar showing my new design; FIG. 2 is a front elevational view; FIG. 3 is a right side elevational view;

FIG. 4 is a rear elevational view; FIG. 5 is a bottom plan view; FIG. 6 is a top plan view; FIG. 7 is a rear elevational view of a modified form of a solid body acoustic guitar showing my new design, wherein the semi-circles are omitted on the rear; FIG. 8 is a front elevational view of a second modified form of the guitar, wherein there are two instead of three centered, broken stripes; FIG. 9 is a bottom plan view thereof; FIG. 10 is a top plan view thereof; FIG. 11 is a rear elevational view thereof; FIG. 12 is a front elevational view of a third modified form of the guitar, wherein there is one instead of three centered, broken stripes; FIG. 13 is a view like FIG. 9 thereof; FIG. 14 is a view like FIG. 10 thereof; FIG. 15 is a view like FIG. 11 thereof; FIG. 16 is a view like FIG. 8 of a fourth modified form of the guitar; FIG. 17 is a view like FIG. 3 thereof; FIG. 18 is a view like FIG. 9 thereof; FIG. 19 is a view like FIG. 10 thereof; FIG. 20 is a view like FIG. 11 thereof; FIG. 21 is a view like FIG. 8 of a fifth modified form of the guitar; FIG. 22 is a view like FIG. 9 thereof; FIG. 23 is a view like FIG. 10 thereof; and FIG. 24 is a view like FIG. 11 thereof. The left sides of the embodiments of the guitar shown in FIGS. 1 and 16 are mirror images of the right sides shown in, respectively, FIGS. 3 and 17; and the sides of the embodiment shown in FIG. 21 are identical to the sides of the embodiment of FIG. 16.

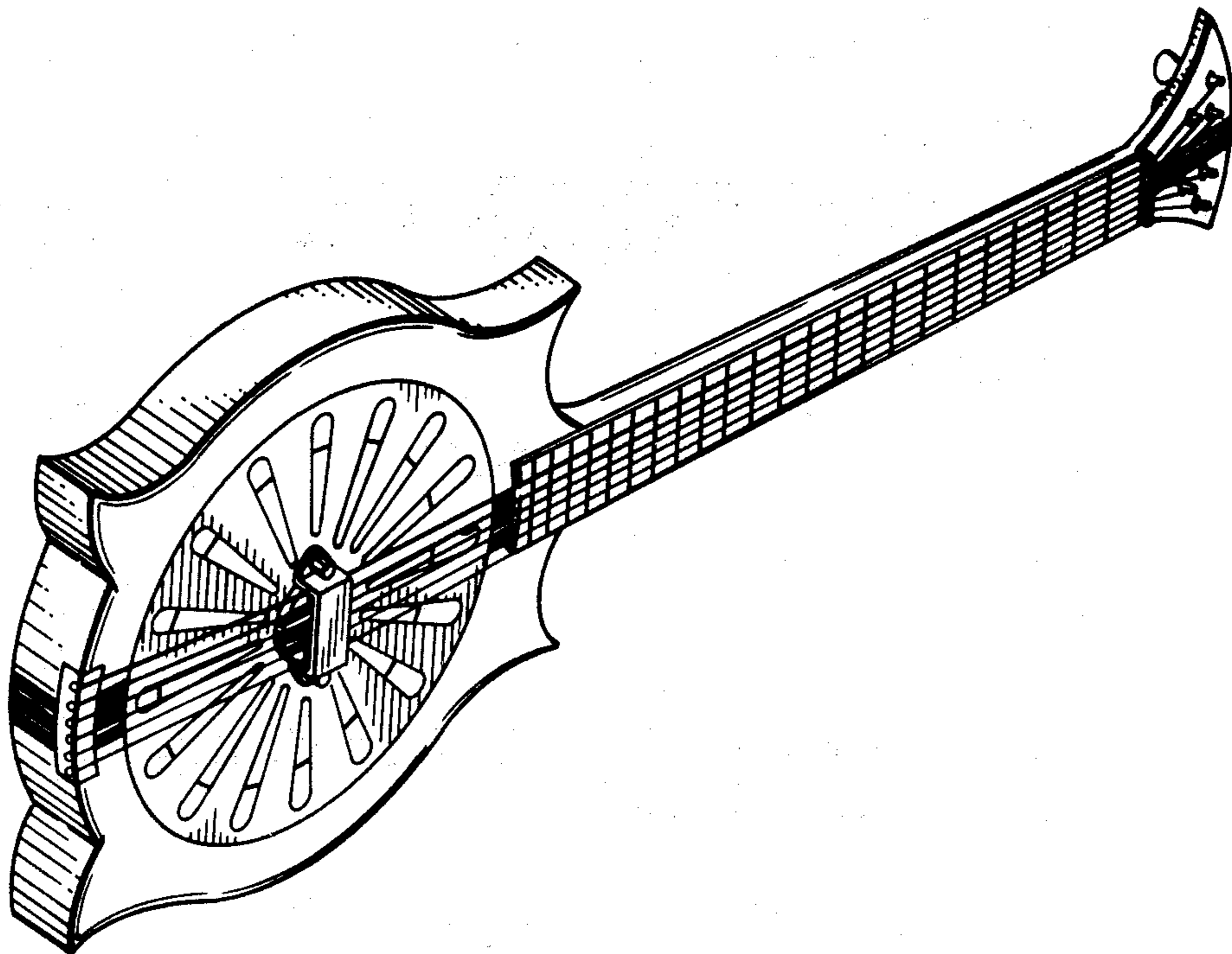

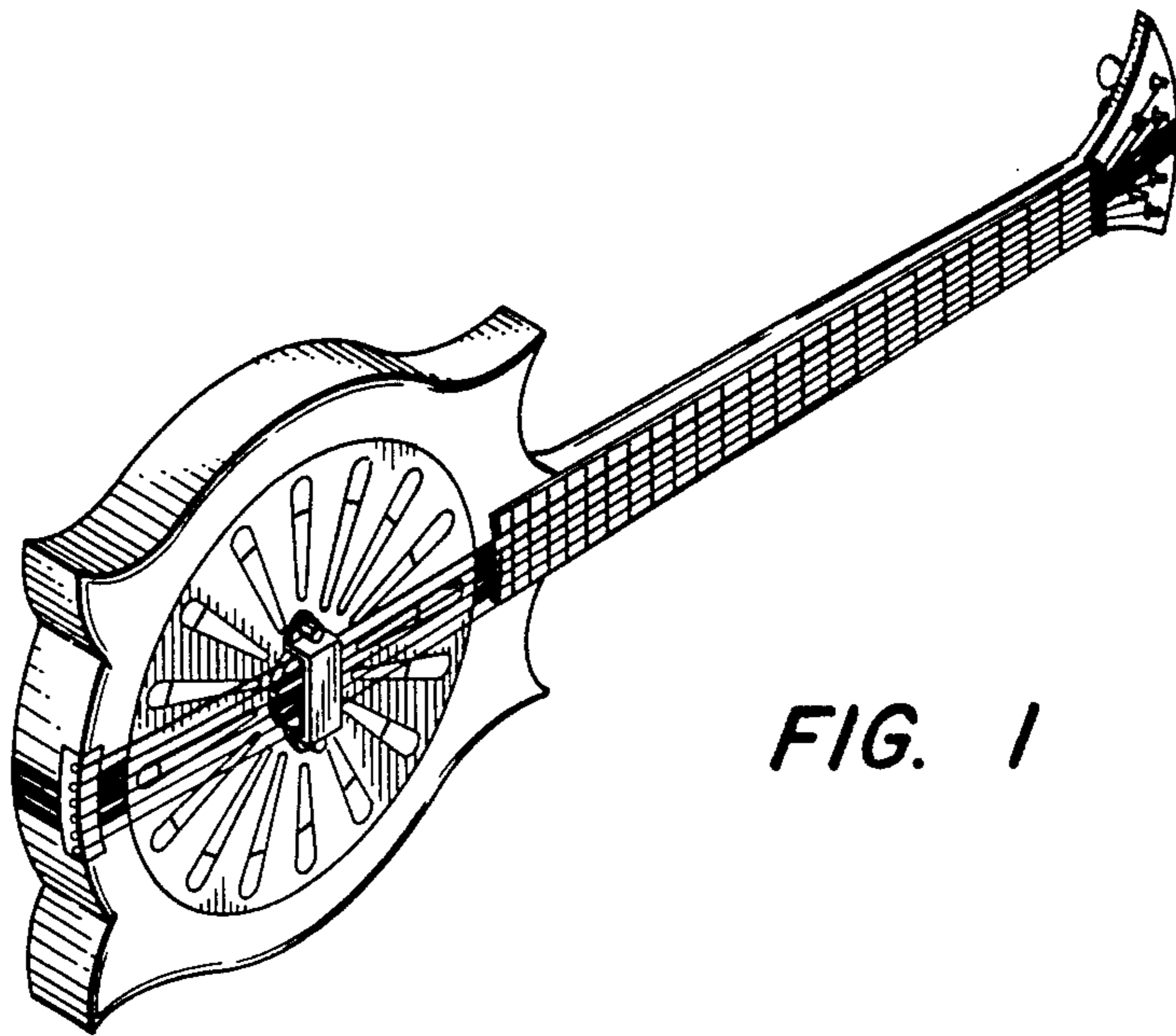

FIG. 1

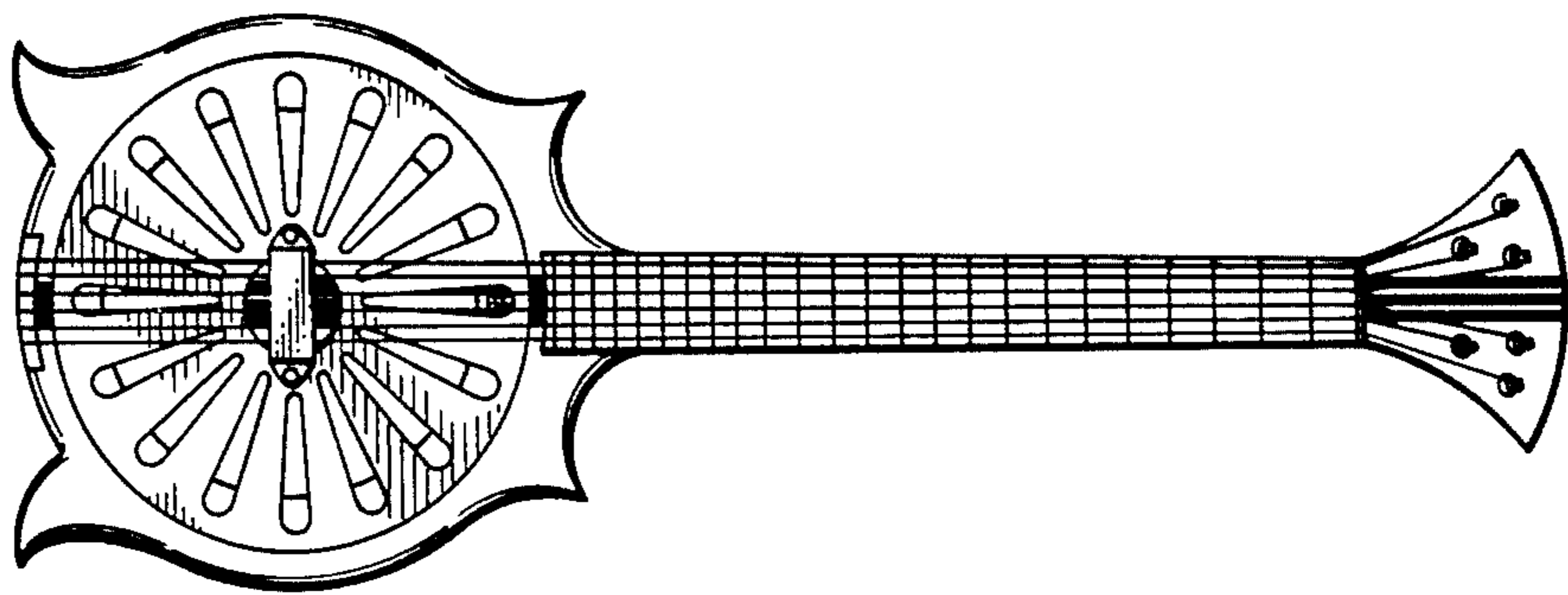

FIG. 2

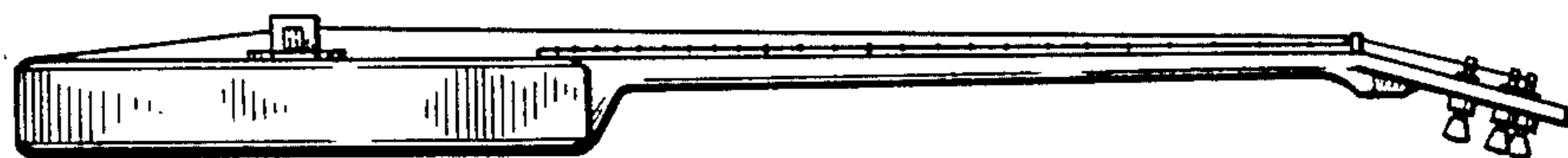
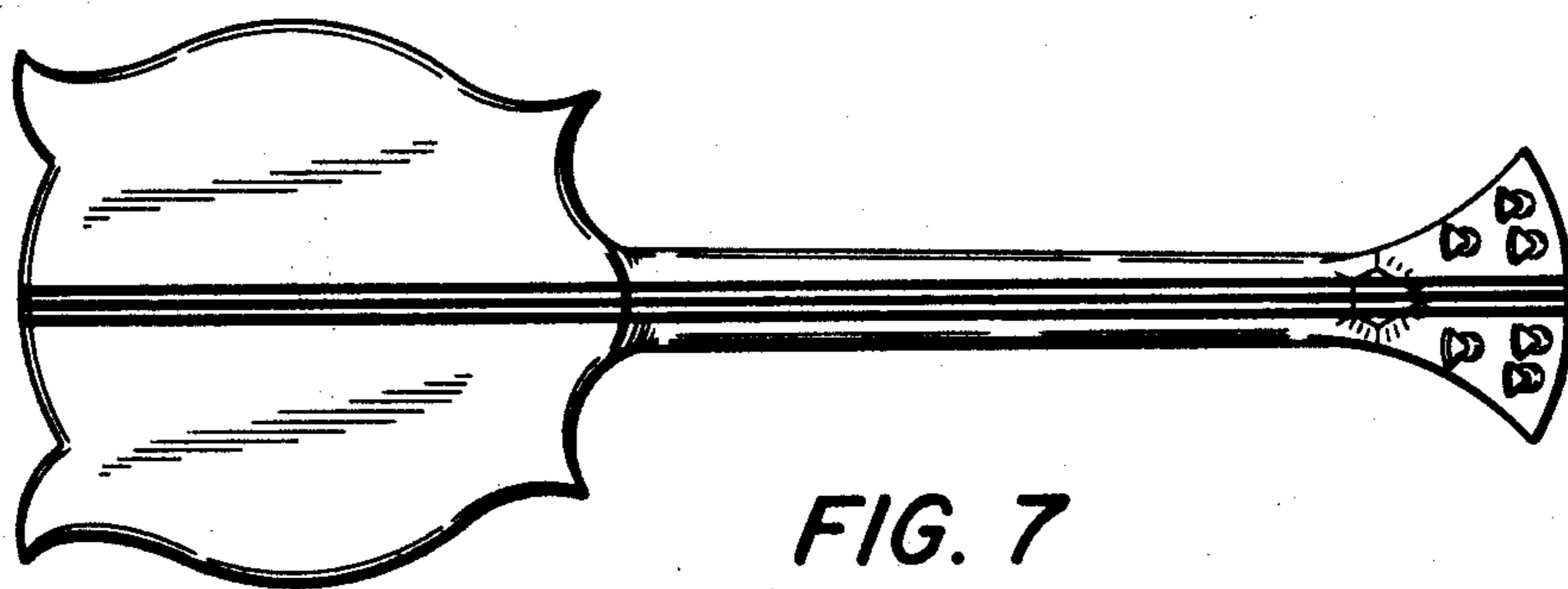
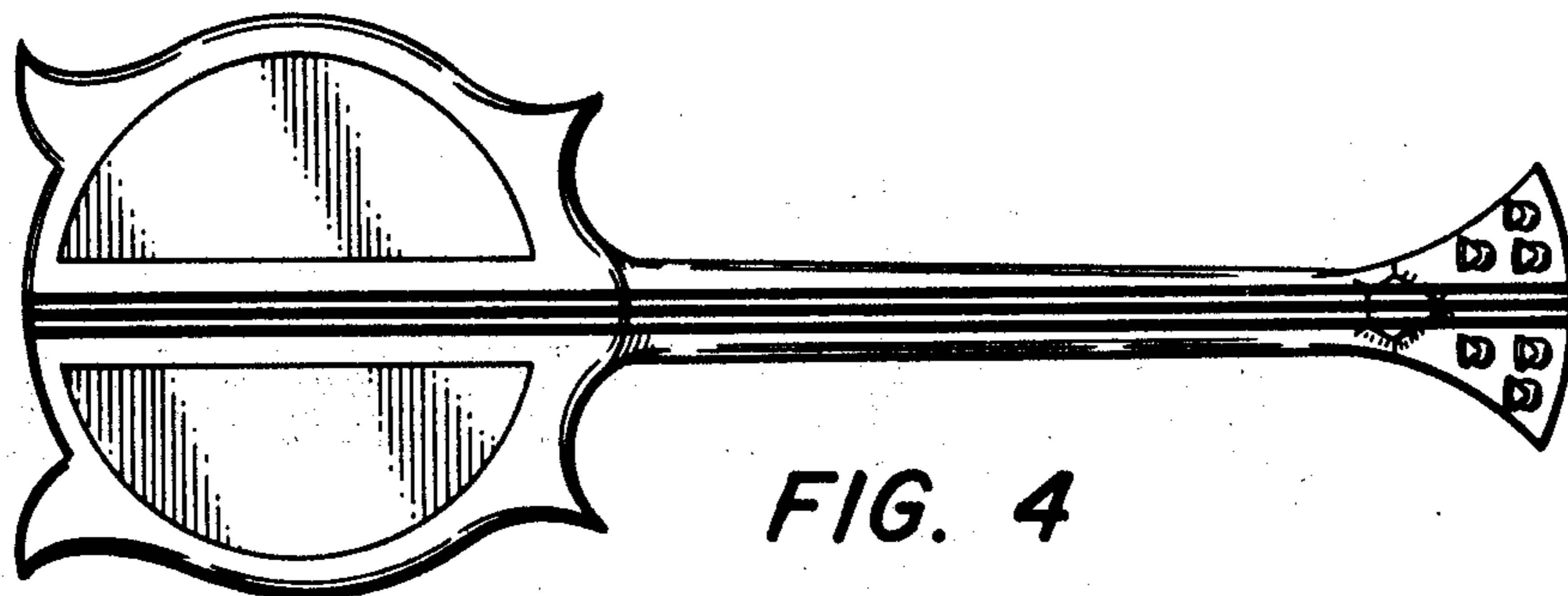

FIG. 3



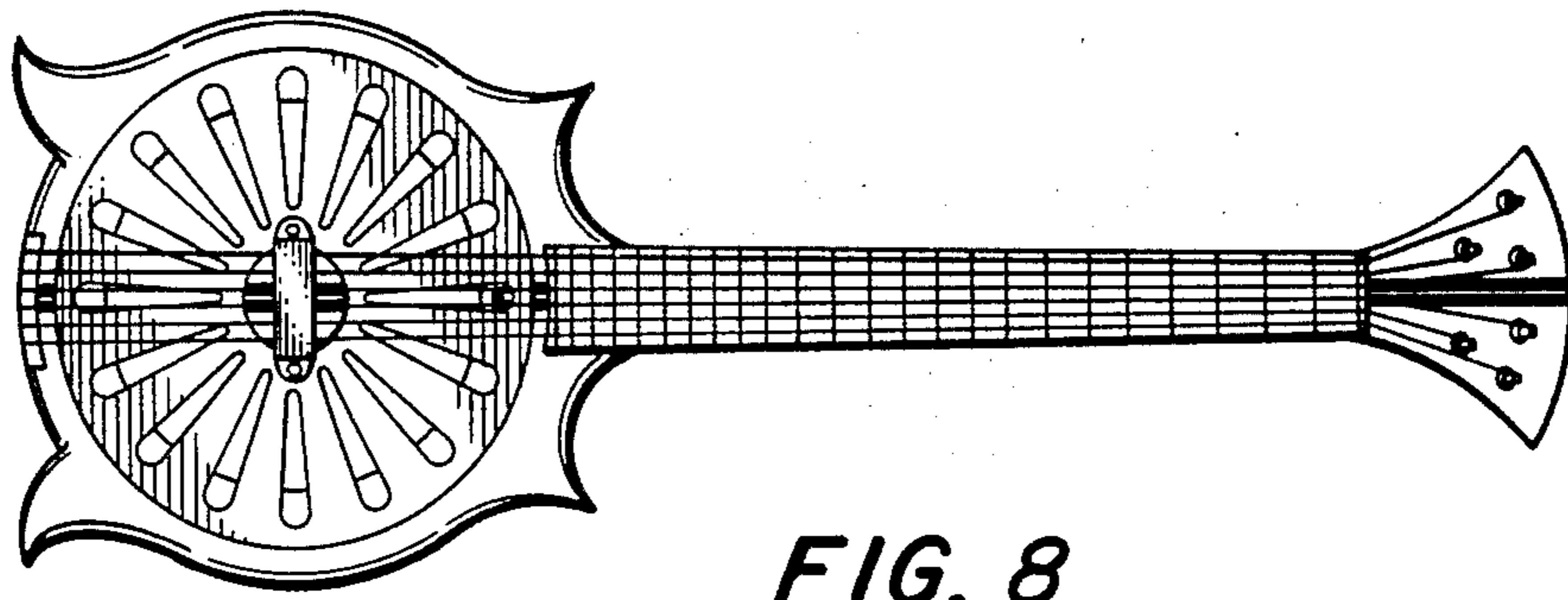

FIG. 8



FIG. 9



FIG. 10

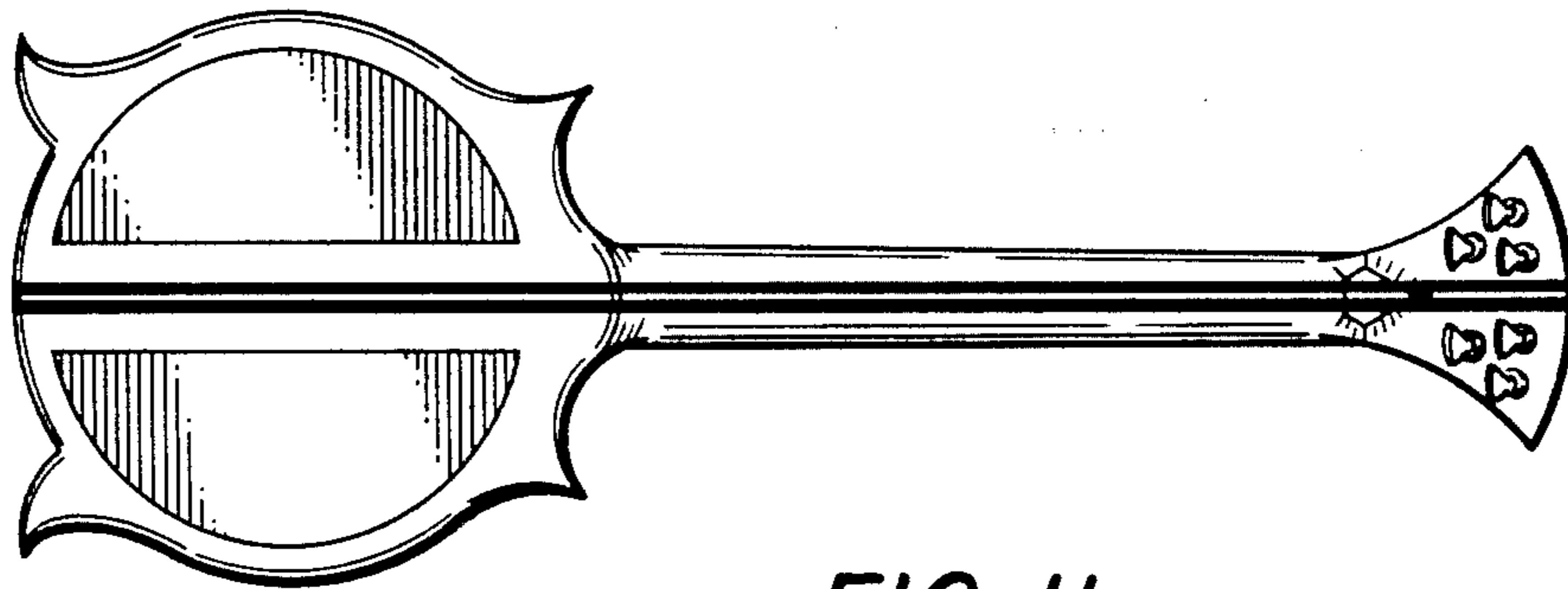

FIG. 11

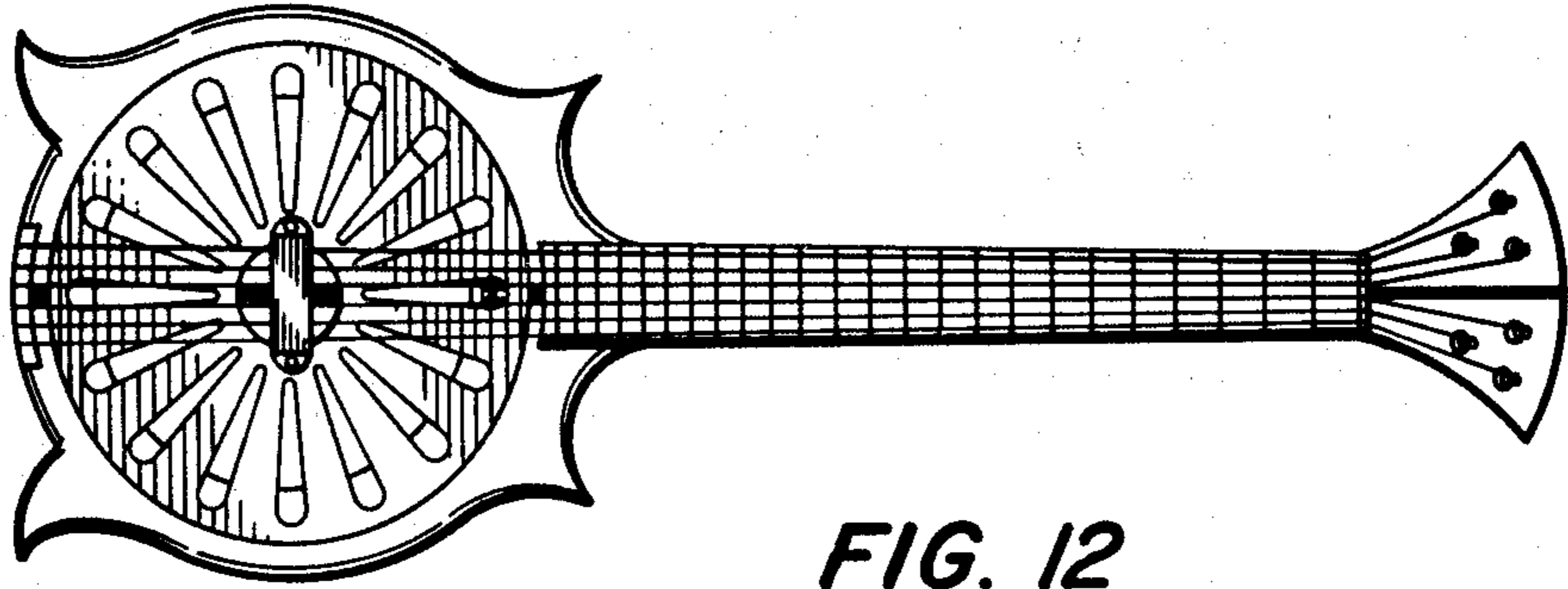

FIG. 12



FIG. 13



FIG. 14

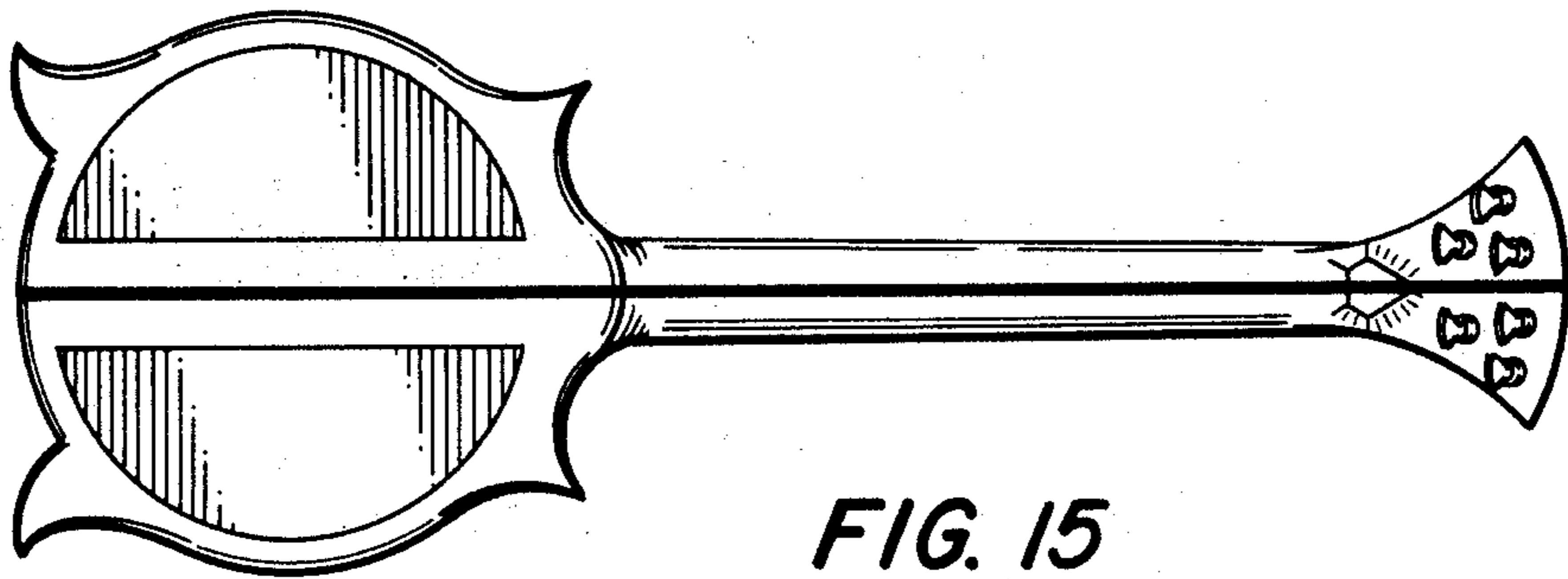

FIG. 15

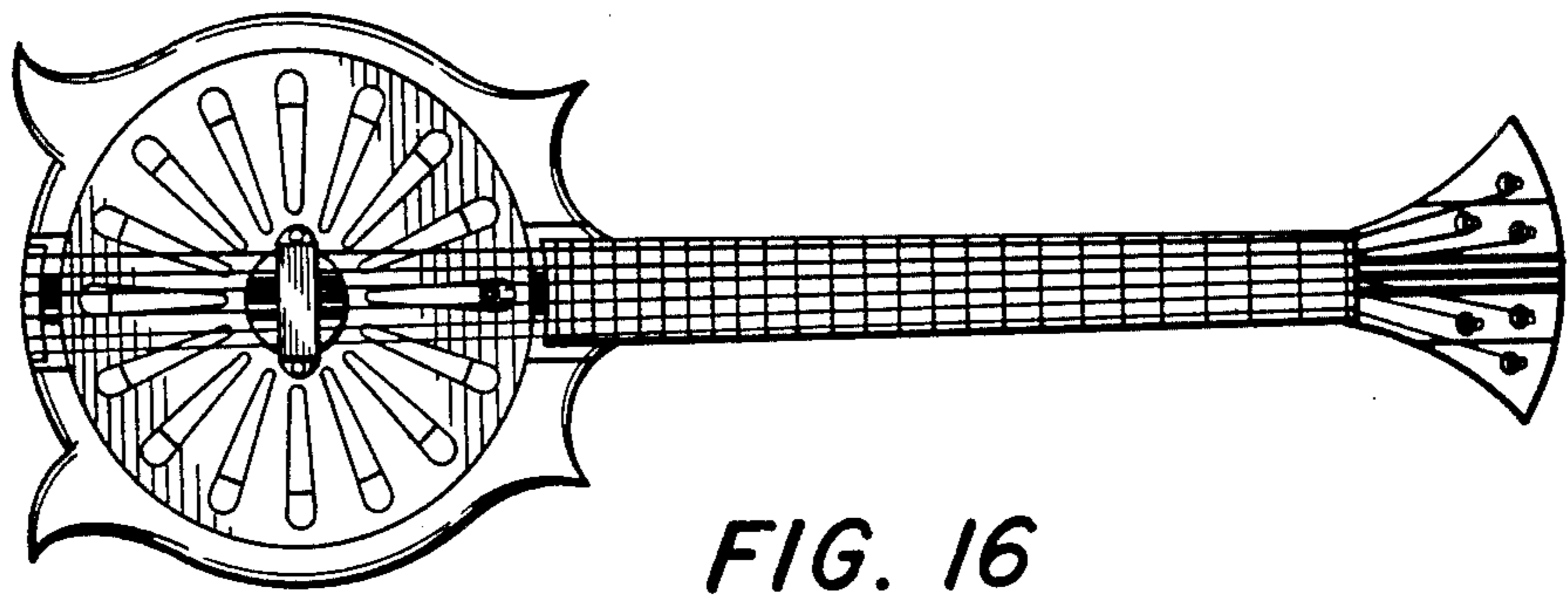

FIG. 16

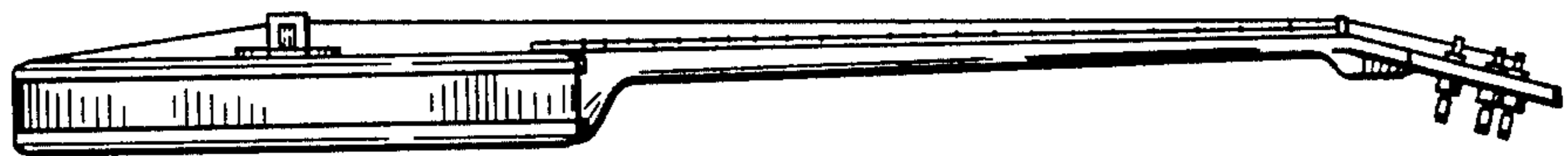

FIG. 17



FIG. 18



FIG. 19

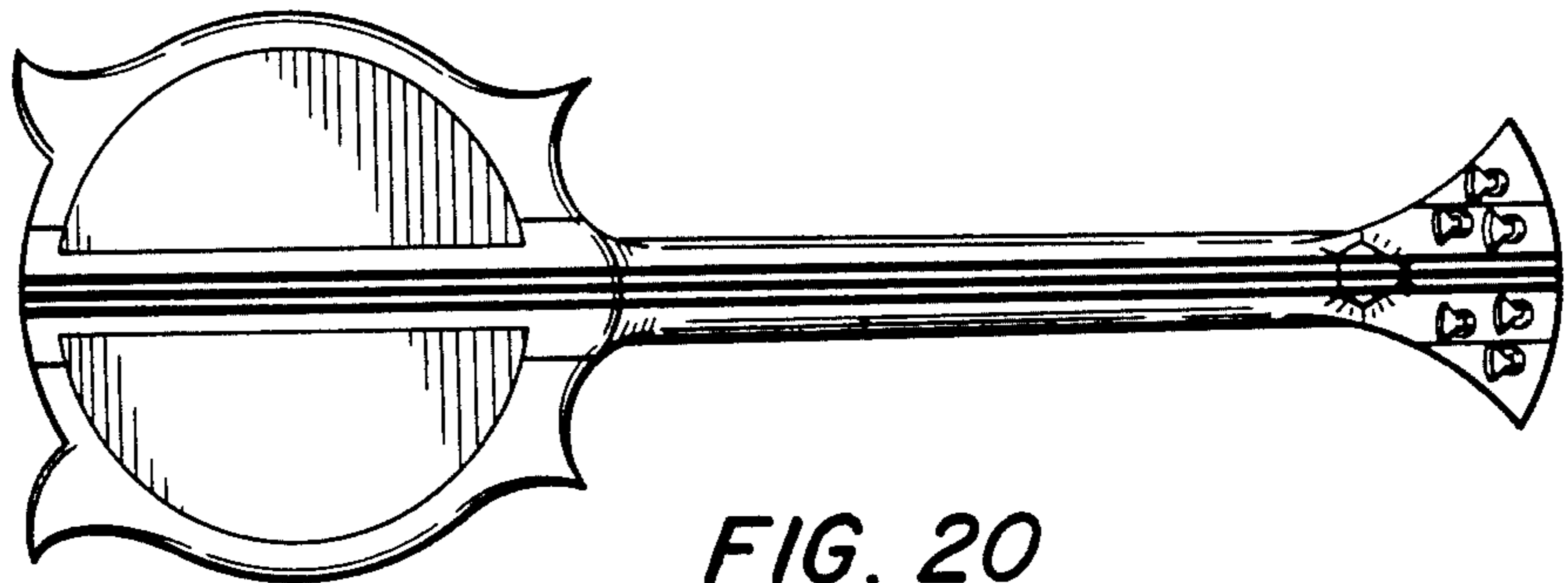

FIG. 20

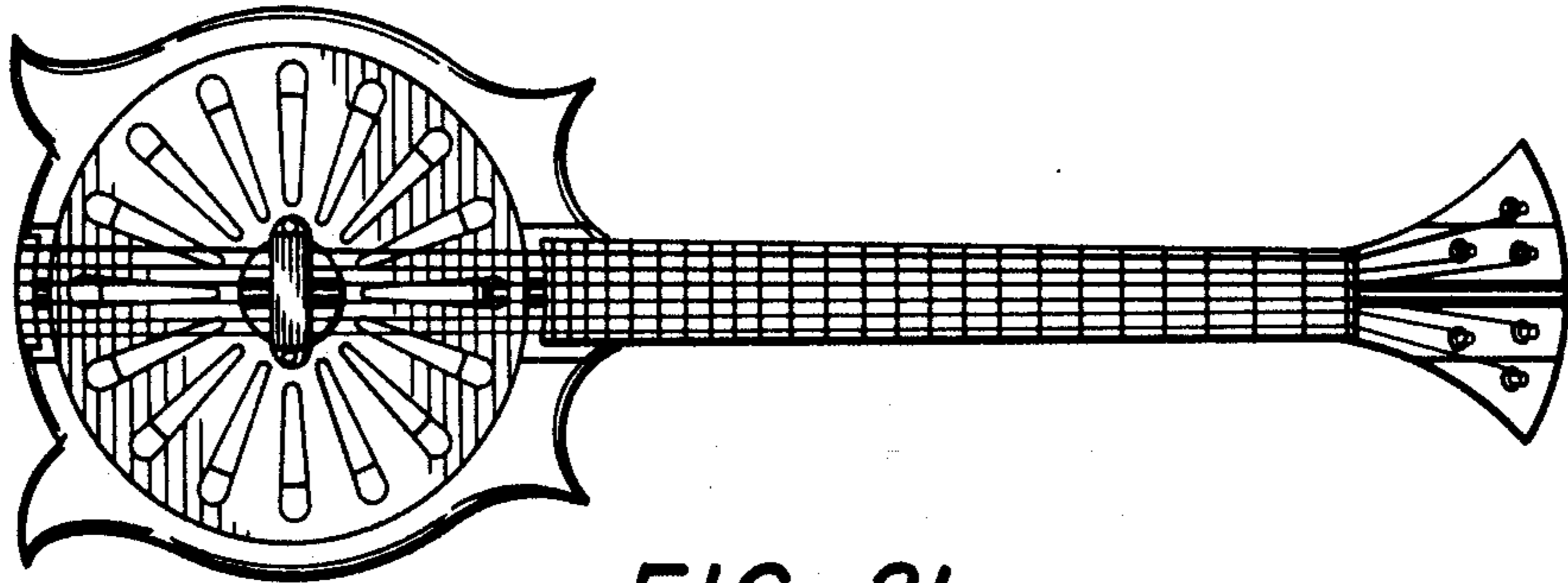

FIG. 21

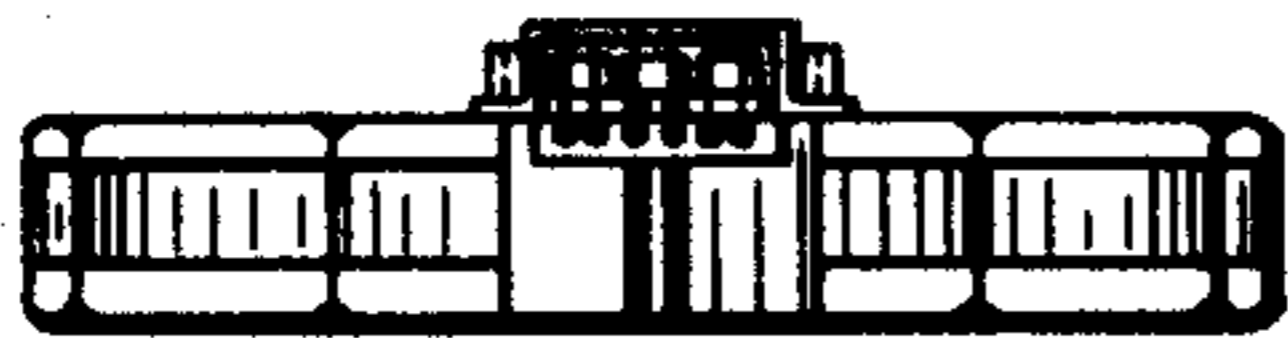

FIG. 22



FIG. 23

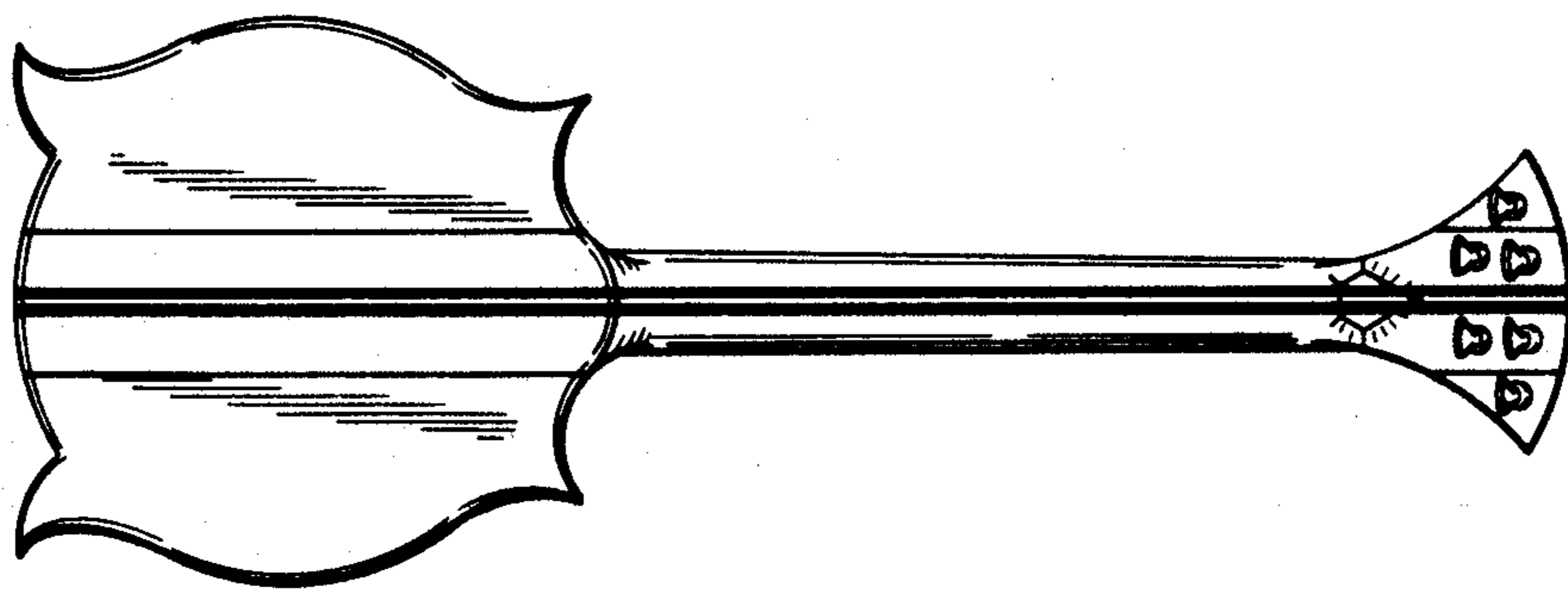

FIG. 24