

United States Patent [19]

Murakami et al.

[11] Patent Number: Des. 274,620

[45] Date of Patent: ** Jul. 10, 1984

[54] HOUSING FOR A PORTABLE INTERNAL COMBUSTION ENGINE

[75] Inventors: Michitsugu Murakami; Kazuo Mashimo, both of Tokyo, Japan

[73] Assignee: Komatsu Zenoah Co., Tokyo, Japan

[**] Term: 14 Years

[21] Appl. No.: 225,140

[22] Filed: Mar. 5, 1981

[30] Foreign Application Priority Data

Jul. 15, 1980 [JP] Japan 55-28080

[52] U.S. Cl. D15/1

[58] Field of Search D15/1; 123/195 R; D8/8; 30/276

[56] References Cited

U.S. PATENT DOCUMENTS

D. 260,394 8/1981 Tuggle D15/1

Primary Examiner—James M. Gandy

Attorney, Agent, or Firm—Jones & Askew

[57] CLAIM

The ornamental design for a housing for a portable internal combustion engine, substantially as shown.

DESCRIPTION

FIG. 1 is a front elevation view of the housing for a portable internal combustion engine;

FIG. 2 is a right side elevation view thereof;

FIG. 3 is a left side elevation view thereof;

FIG. 4 is a top plan view thereof;

FIG. 5 is a bottom plan view thereof;

FIG. 6 is a rear elevation view of the housing for a portable internal combustion engine.

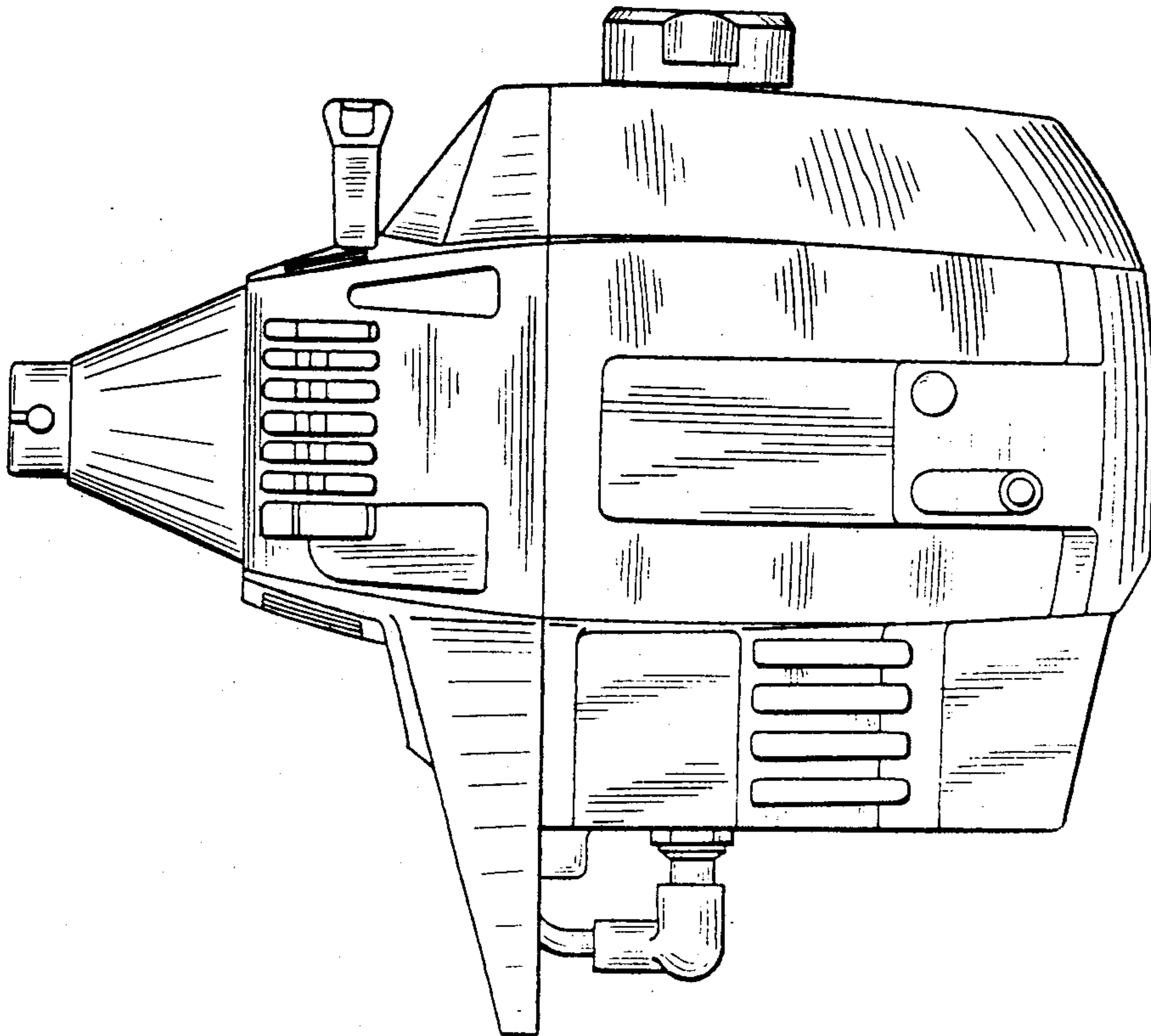

FIG. 1

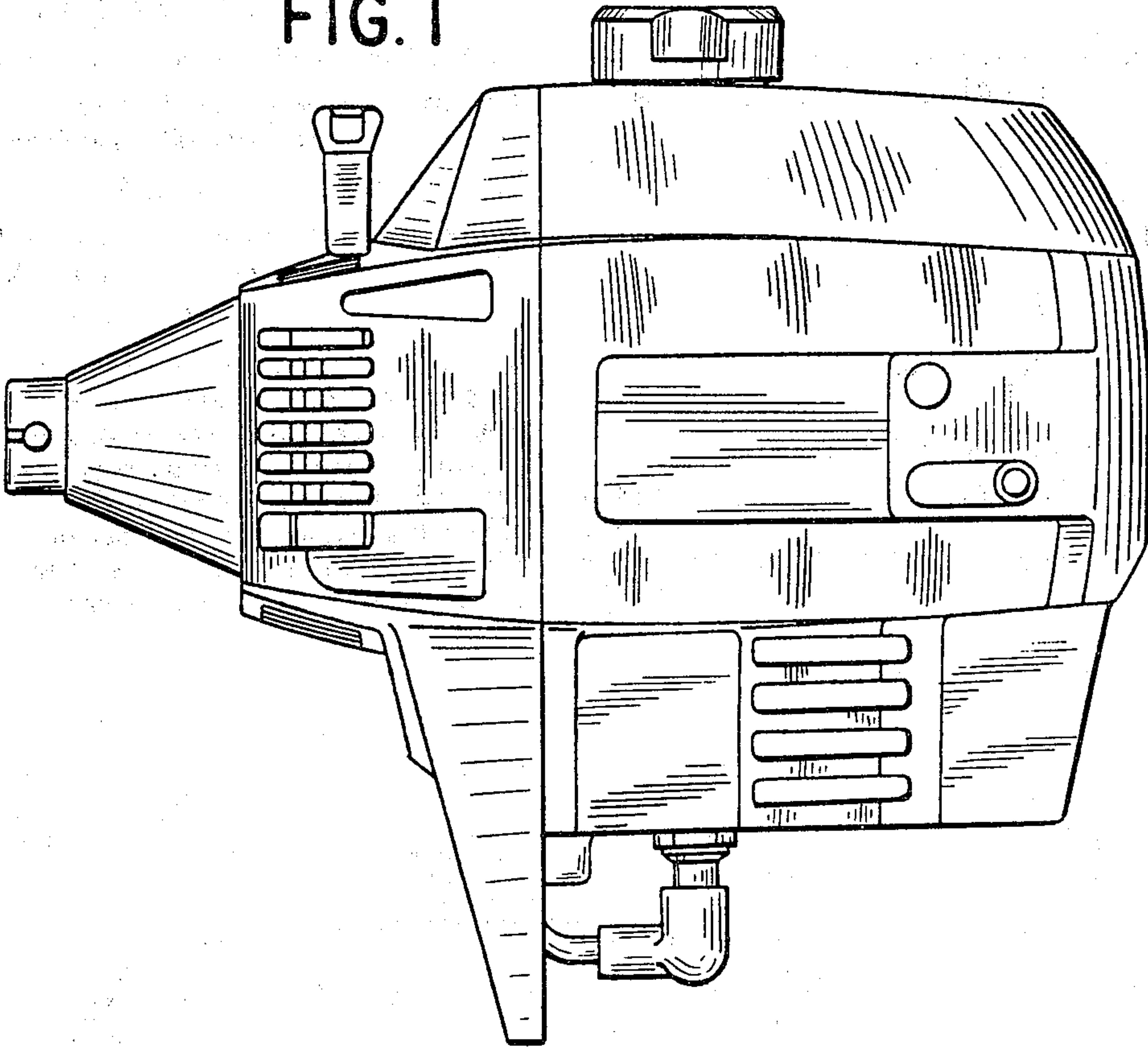

FIG. 2

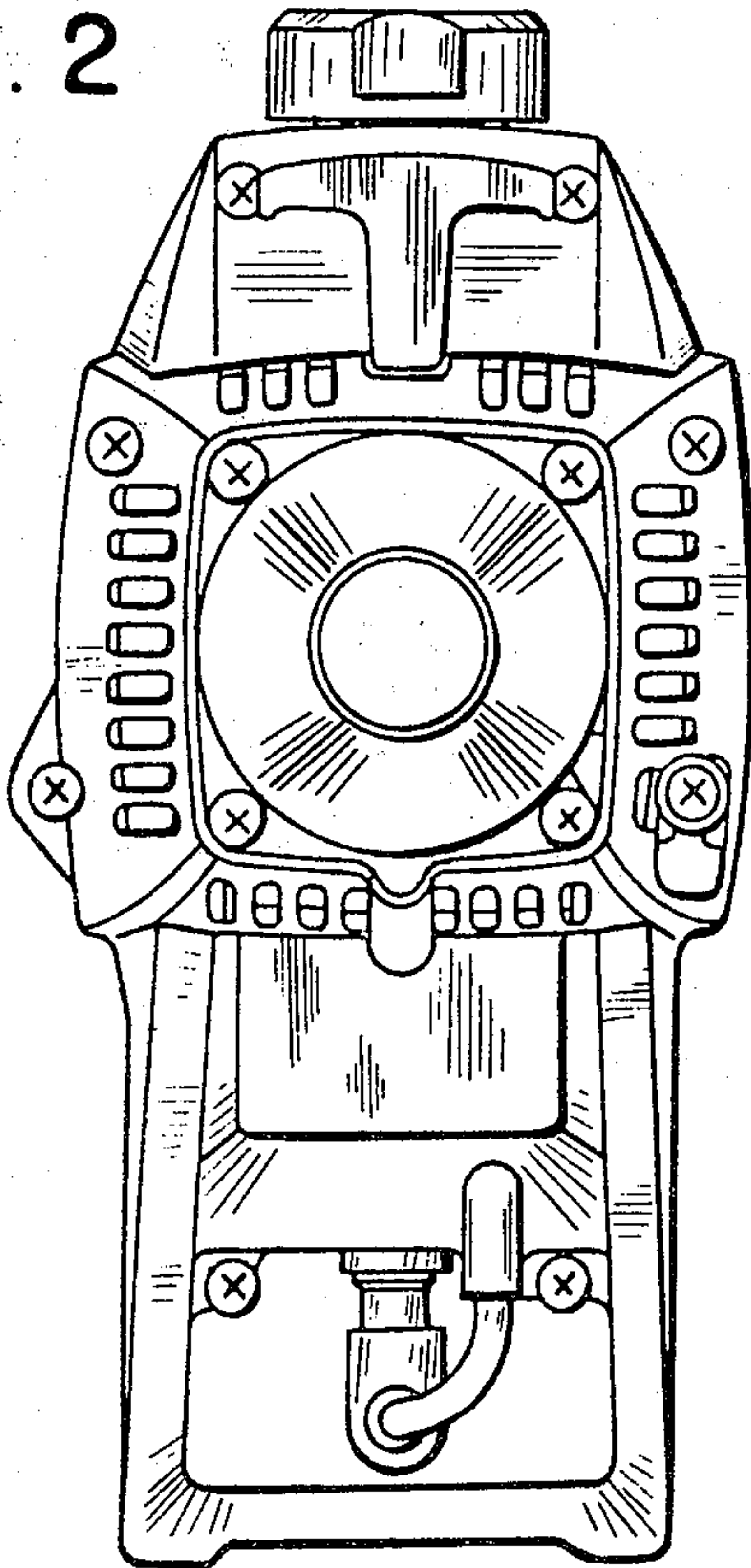

FIG. 3

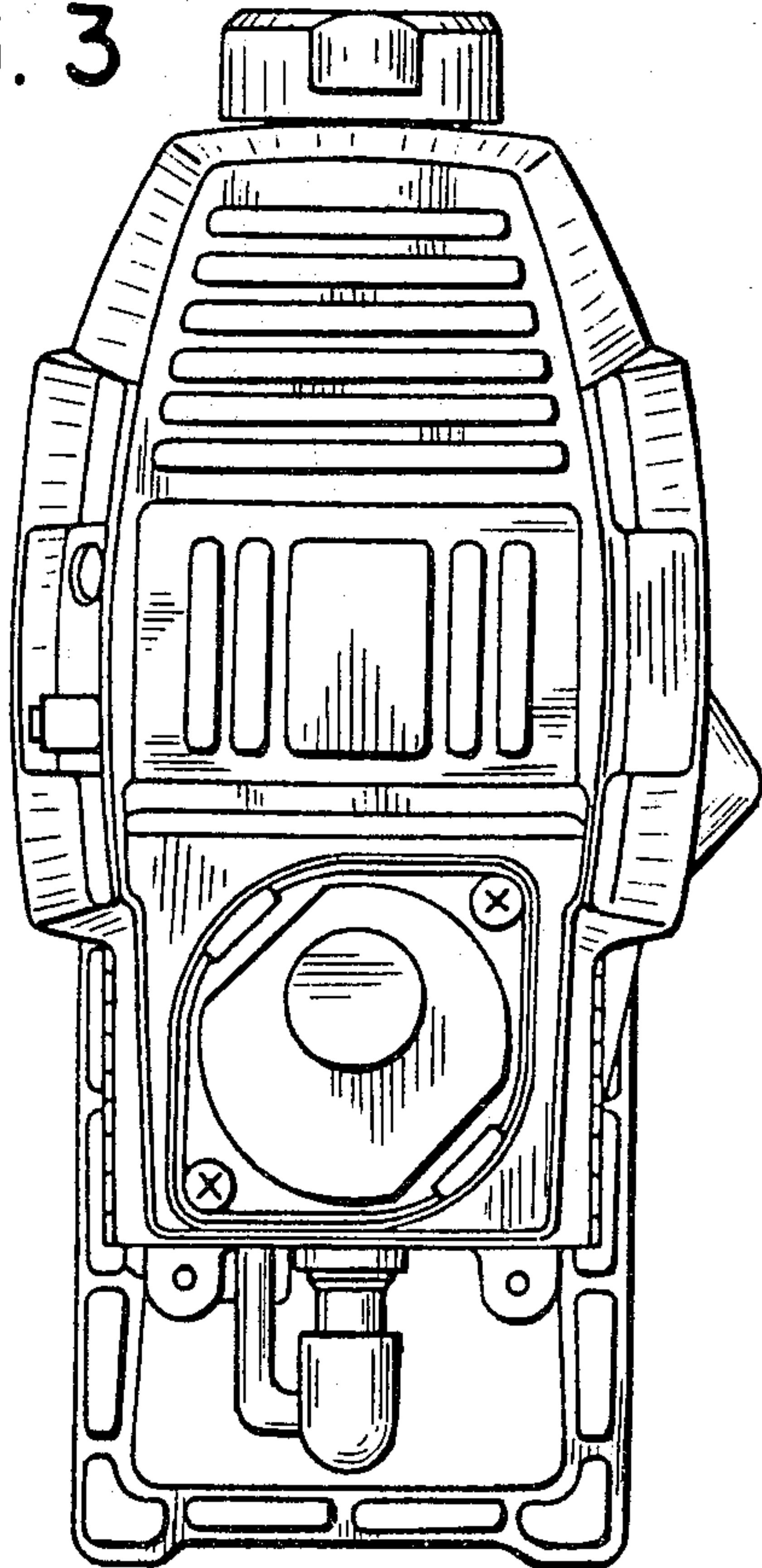

FIG. 4

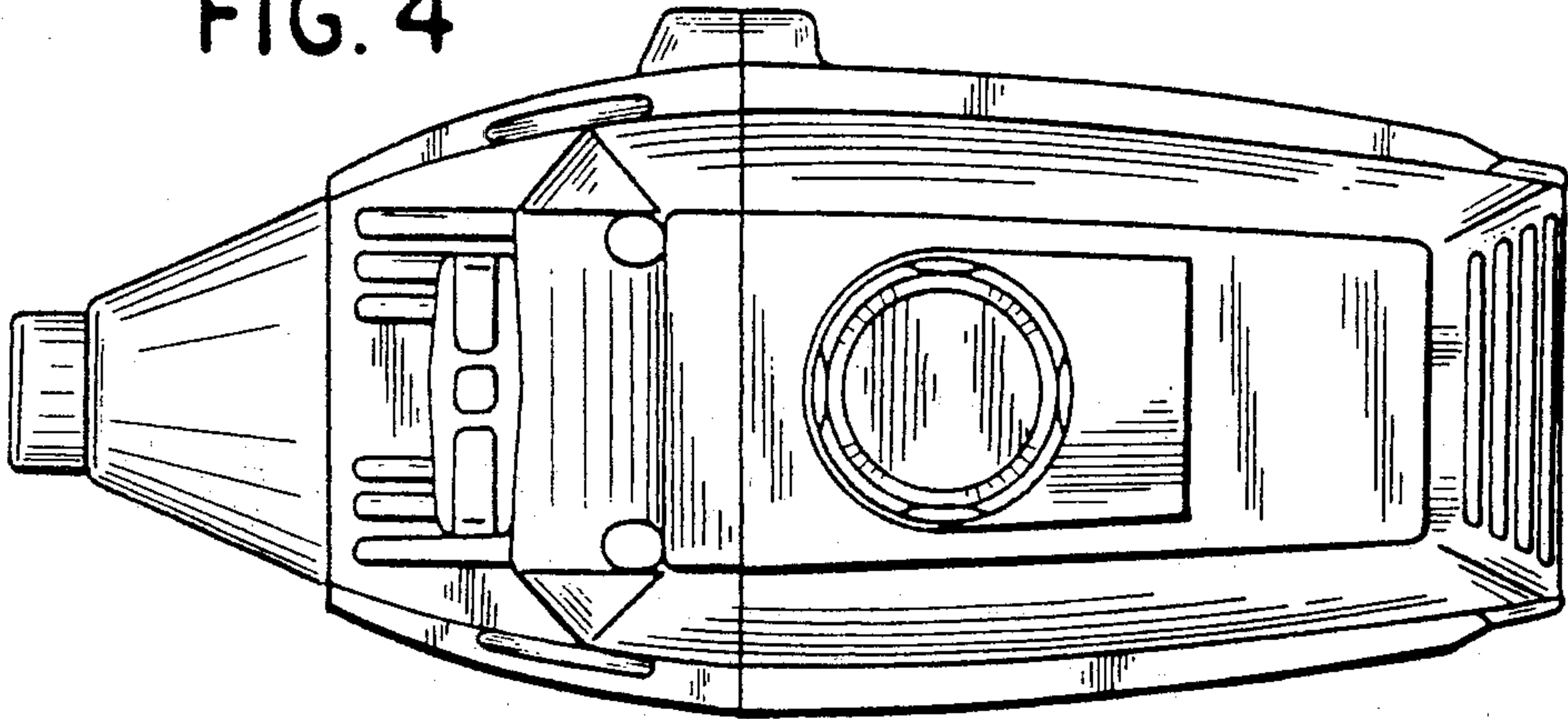
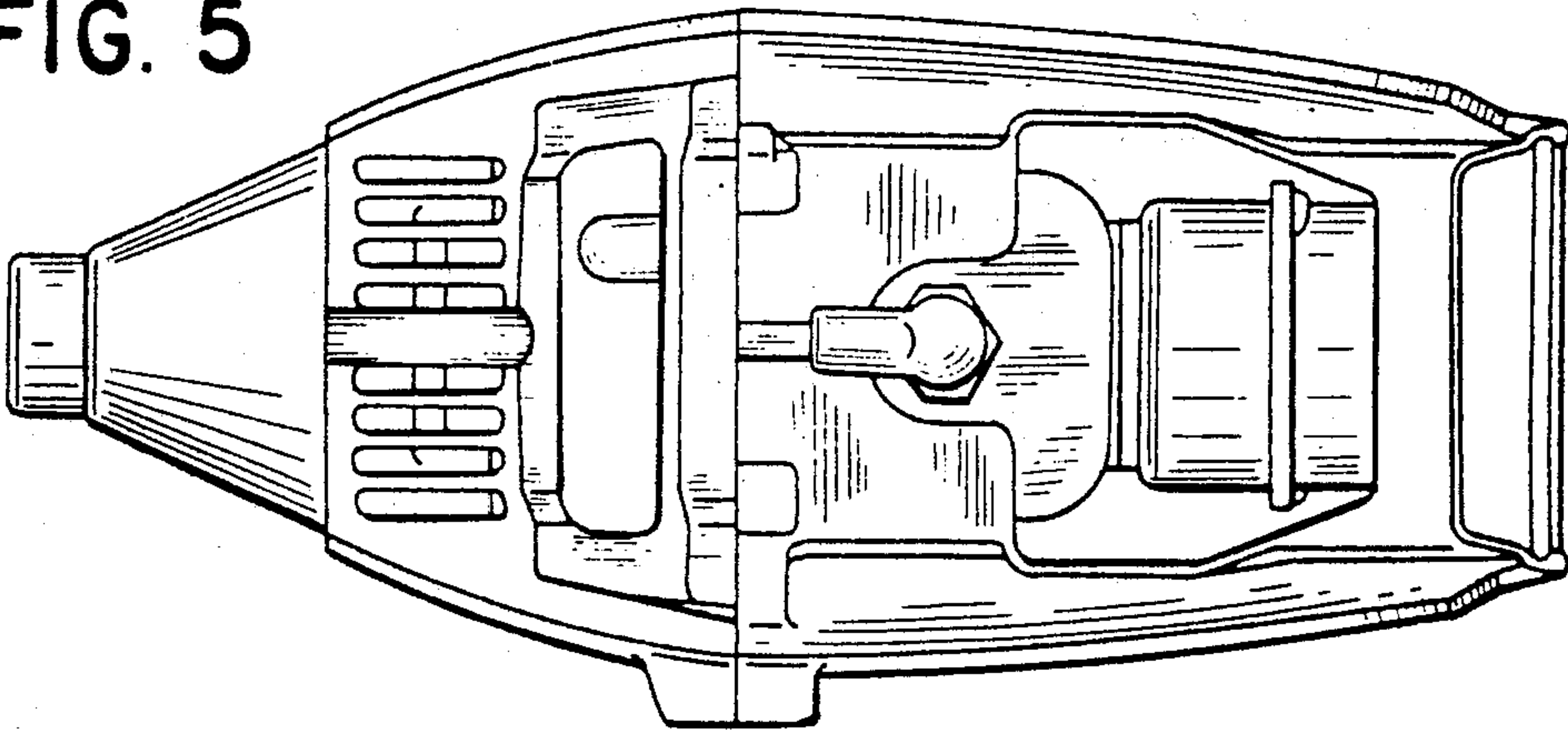

FIG. 5



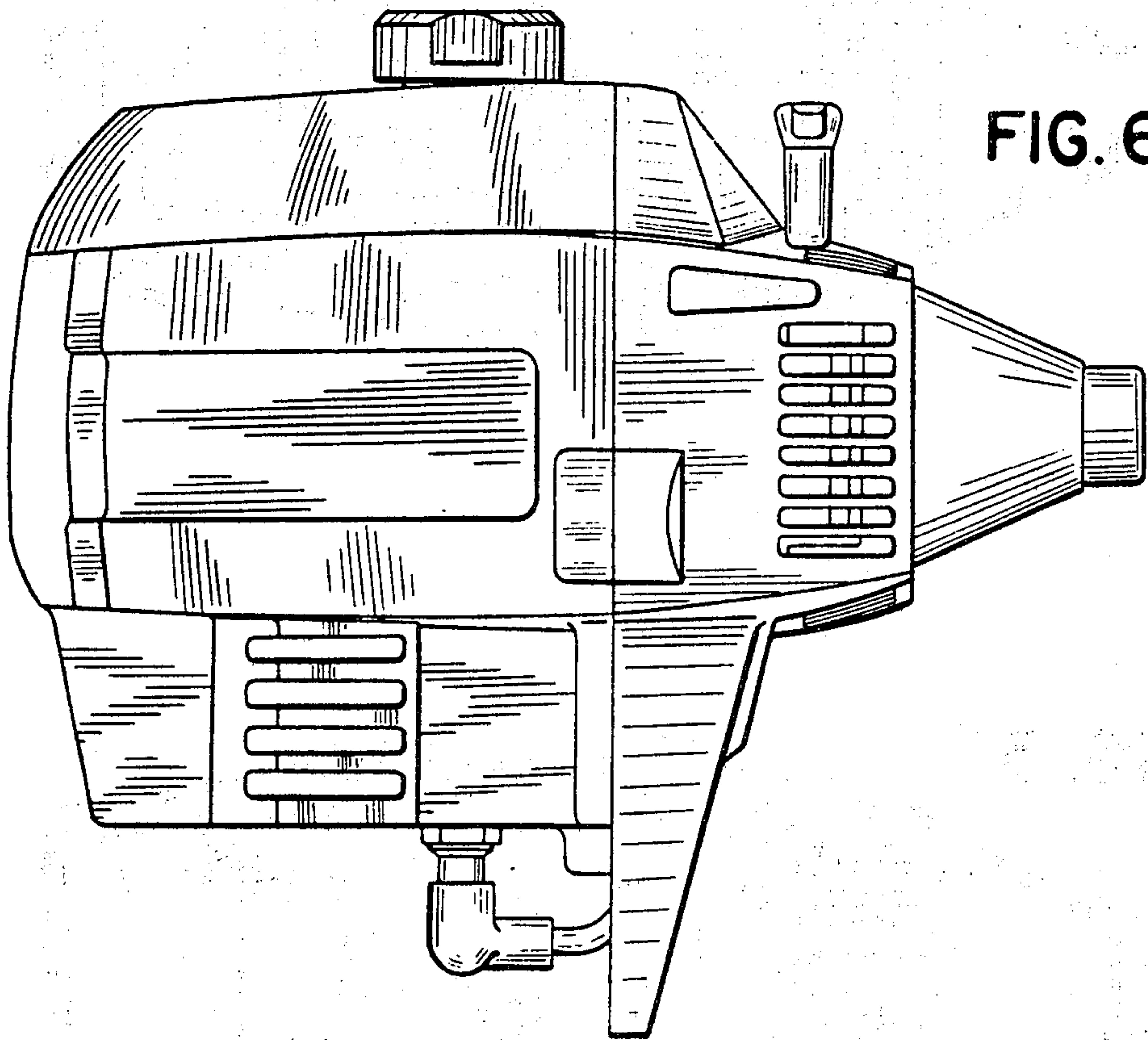

FIG. 6