

[54] CONDUCTOR INSULATOR WITH WATERSHEDS

[75] Inventor: Richard N. Essig, Jackson, Mich.

[73] Assignee: Plastigage Corporation, Jackson, Mich.

[**] Term: 14 Years

[21] Appl. No.: 324,013

[22] Filed: Nov. 23, 1981

[52] U.S. Cl. D13/18

[58] Field of Search D13/17, 18; 174/45 R, 174/158 R, 158 F, 163 F, 163 R, 164, 179, 137

[56] References Cited

U.S. PATENT DOCUMENTS

D. 49,538	8/1916	Goddard	D13/18
D. 259,113	5/1981	Essig	D13/18
D. 261,756	11/1981	Essig	D13/18
595,089	12/1897	Anderson	174/158 R X
1,465,731	8/1923	Hawkins	174/45 R
2,785,219	3/1957	Rudner	174/158 R X
3,555,747	1/1971	Taylor	174/45 R X
3,582,538	6/1971	Killian et al.	174/158 R

FOREIGN PATENT DOCUMENTS

7613099	5/1977	Netherlands	174/163 F
---------	--------	-------------	-------	-----------

Primary Examiner—Susan J. Lucas
Attorney, Agent, or Firm—Beaman & Beaman

[57] CLAIM

The ornamental design for a conductor insulator with watersheds, substantially as shown and described.

DESCRIPTION

FIG. 1 is a side elevational view of a conductor insulator with watersheds in accord,
 FIG. 2 is an elevational view as taken from the right of FIG. 1, the opposite side being identical thereto,
 FIG. 3 is a top plan view of FIG. 1,
 FIG. 4 is a bottom view of my new design,
 FIG. 5 is an elevational view of another embodiment of my design, the opposite side being identical thereto,
 FIG. 6 is a side elevational view as taken from the right of FIG. 5, the opposite side being identical thereto,
 FIG. 7 is a top plan view of the embodiment of FIG. 5,
 FIG. 8 is a bottom view of the embodiment of FIG. 5,
 FIG. 9 is a side elevational view of another embodiment of my new design, the opposite side being the mirror image thereof,
 FIG. 10 is a side elevational view as taken from the right of FIG. 9, the opposite side being identical thereto except that the length of the screw is greater,
 FIG. 11 is a top plan view of the embodiment of FIG. 9,
 FIG. 12 is a bottom view of the embodiment of FIG. 9,
 FIG. 13 is a side elevational view of another embodiment of my new design, the opposite side being a mirror image thereof,
 FIG. 14 is a side elevational view as taken from the right of FIG. 13, the opposite side being identical thereto except that the screw is of greater length,
 FIG. 15 is a top plan view of the embodiment of FIG. 13, and
 FIG. 16 is a bottom view of the embodiment of FIG. 13,
 FIG. 17 is a cross-sectional view thereof taken along line 17—17 of FIG. 1.

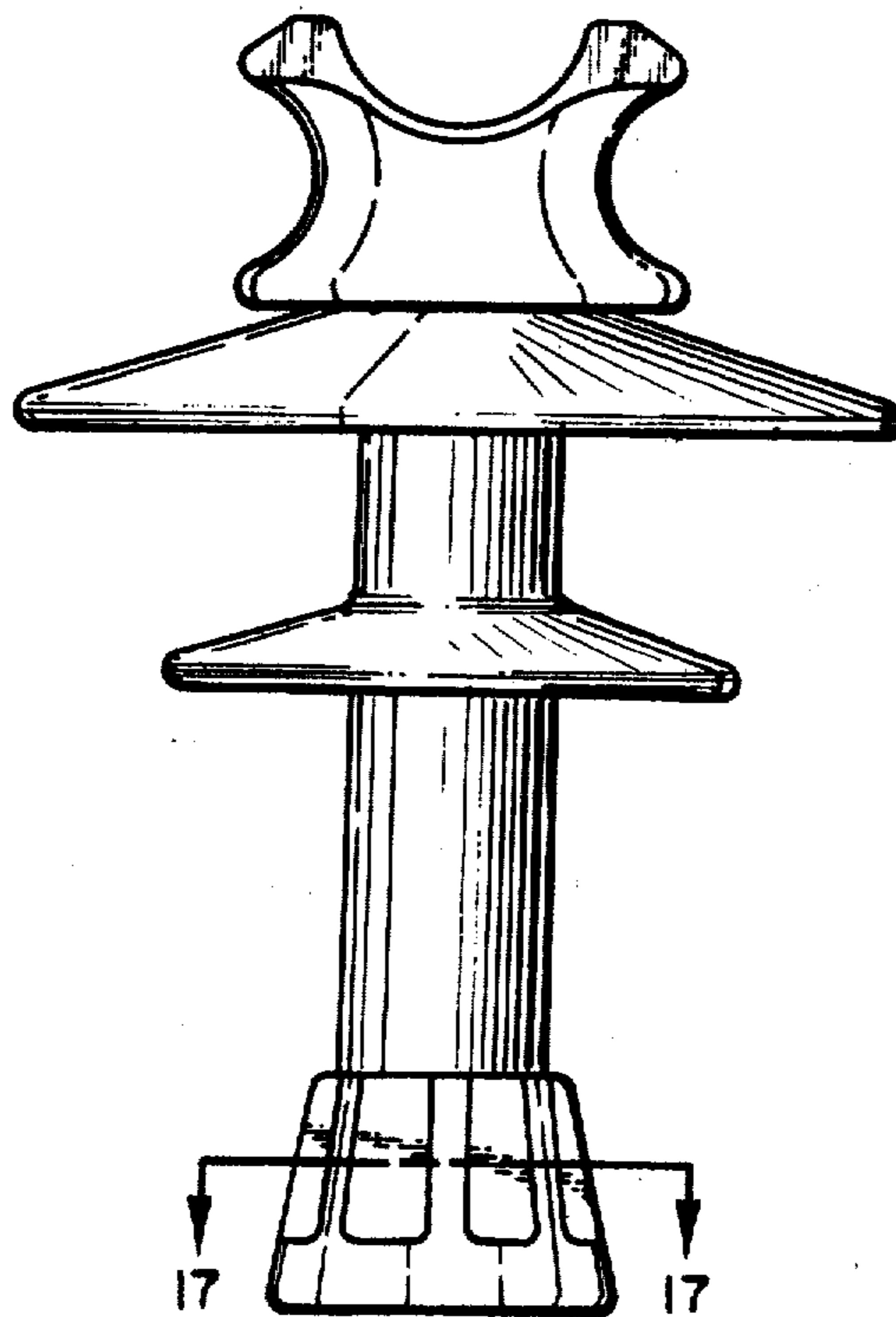

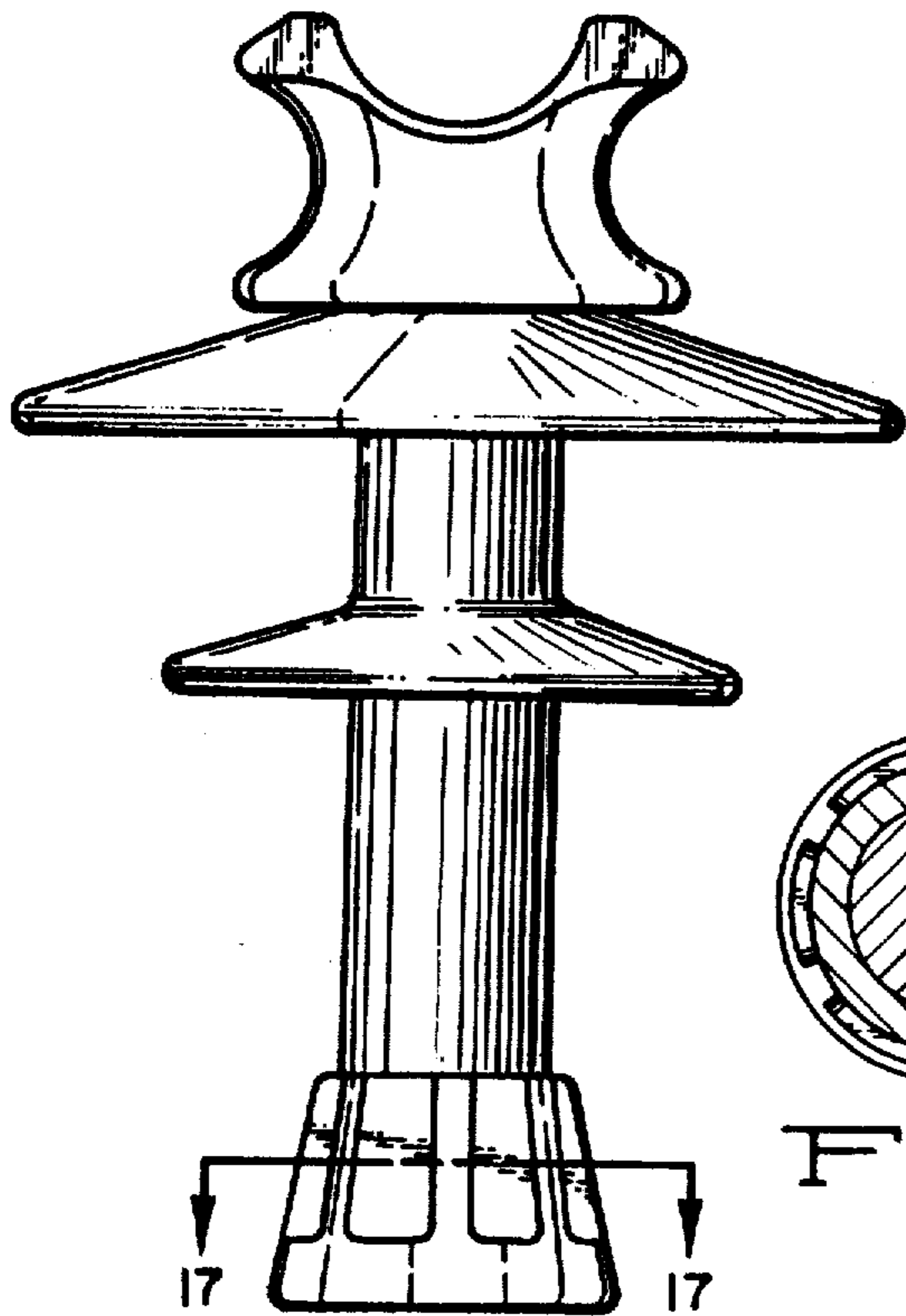

FIG. 1.

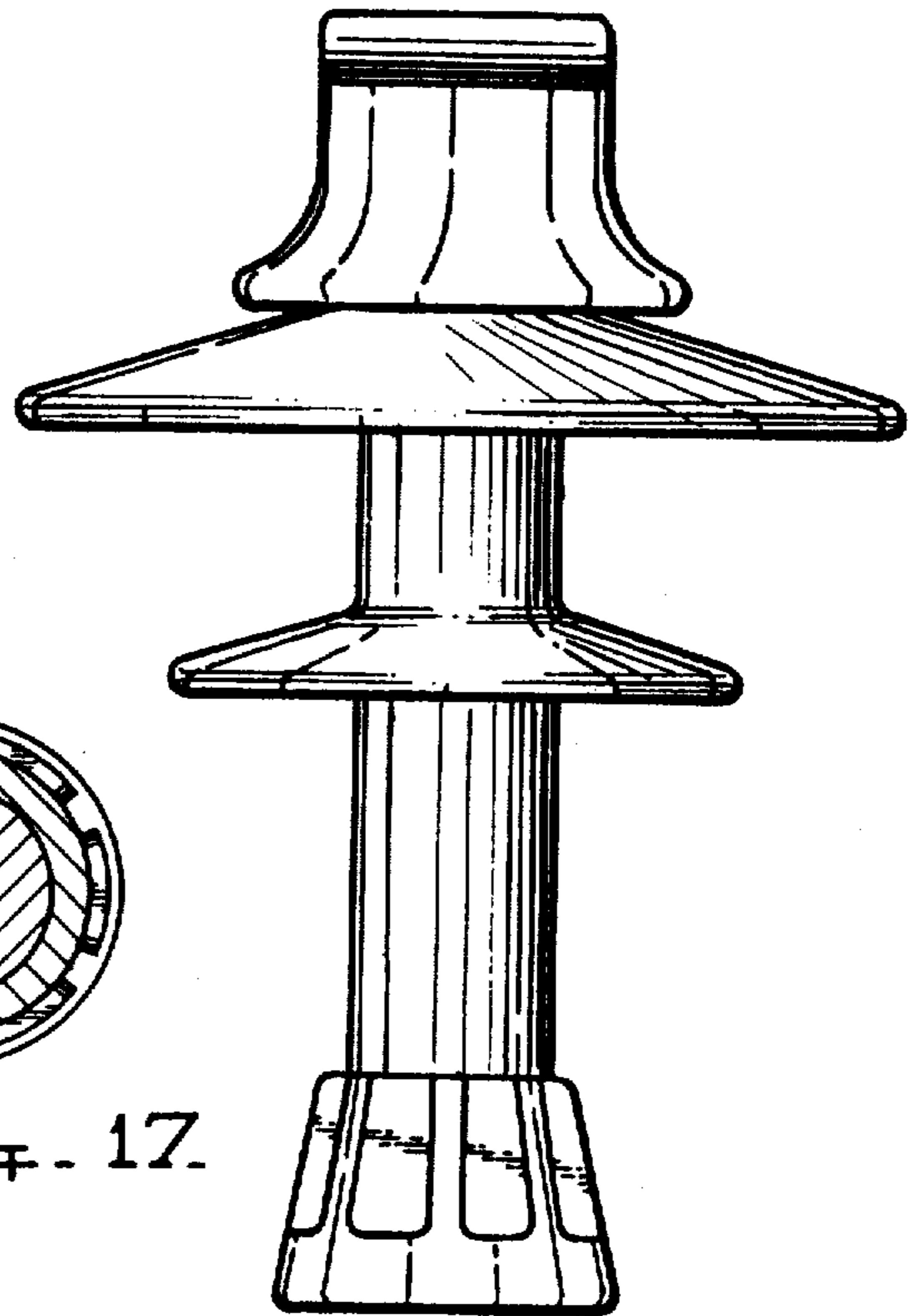

FIG. 2.

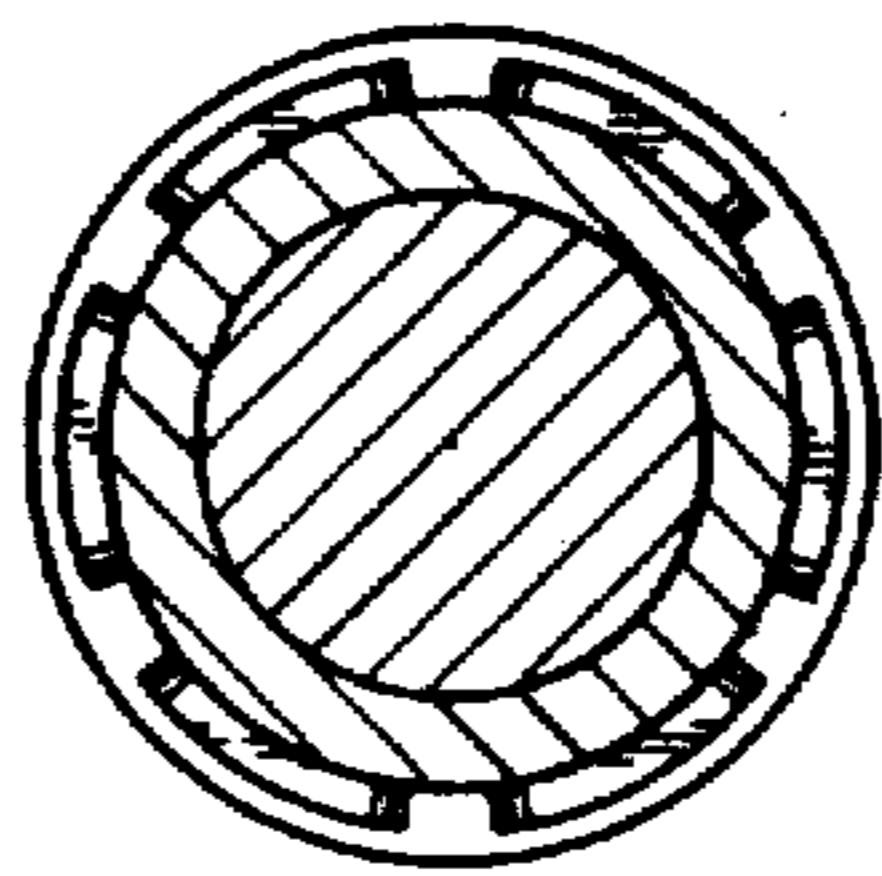

FIG. 17.

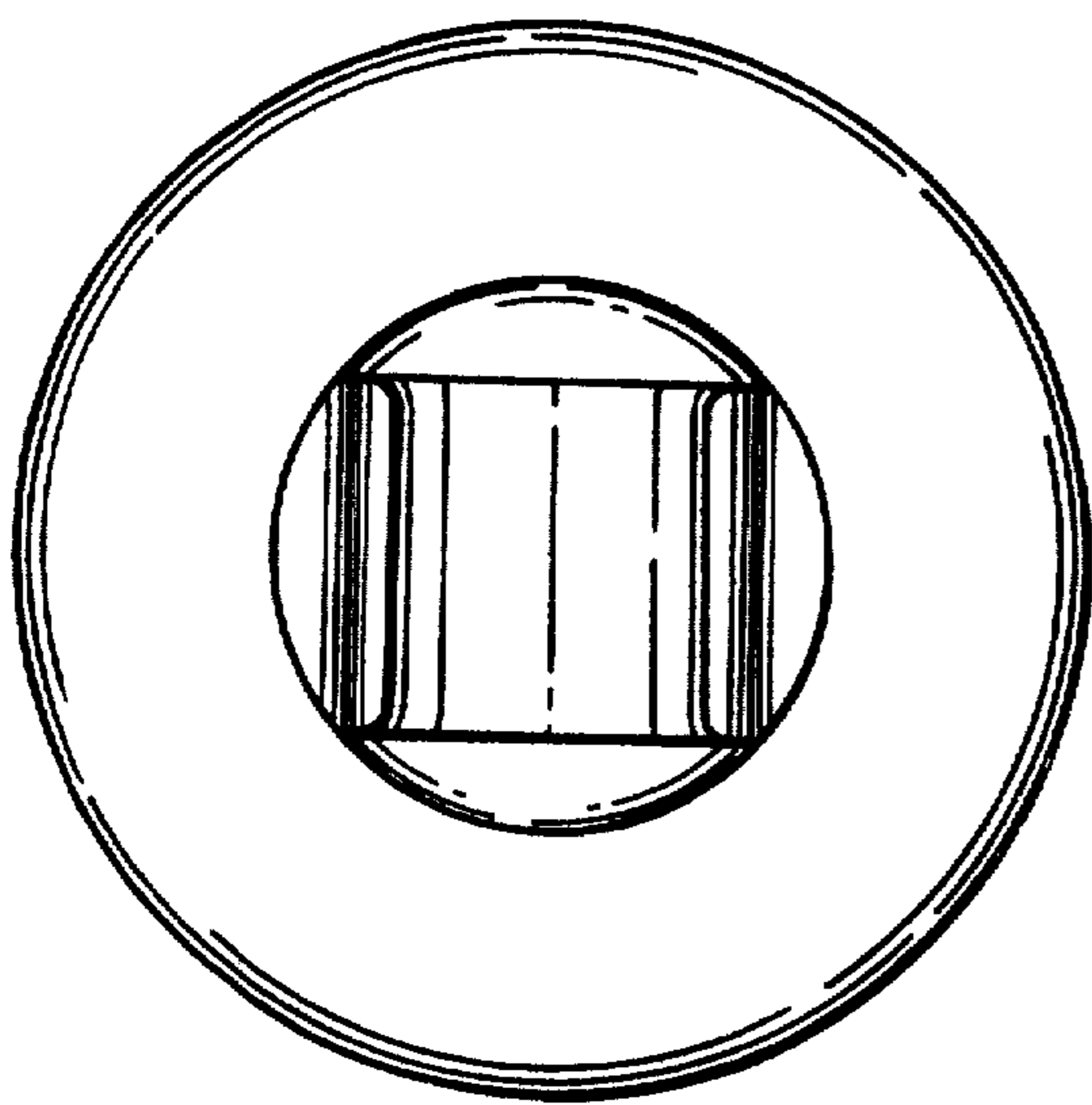

FIG. 3.

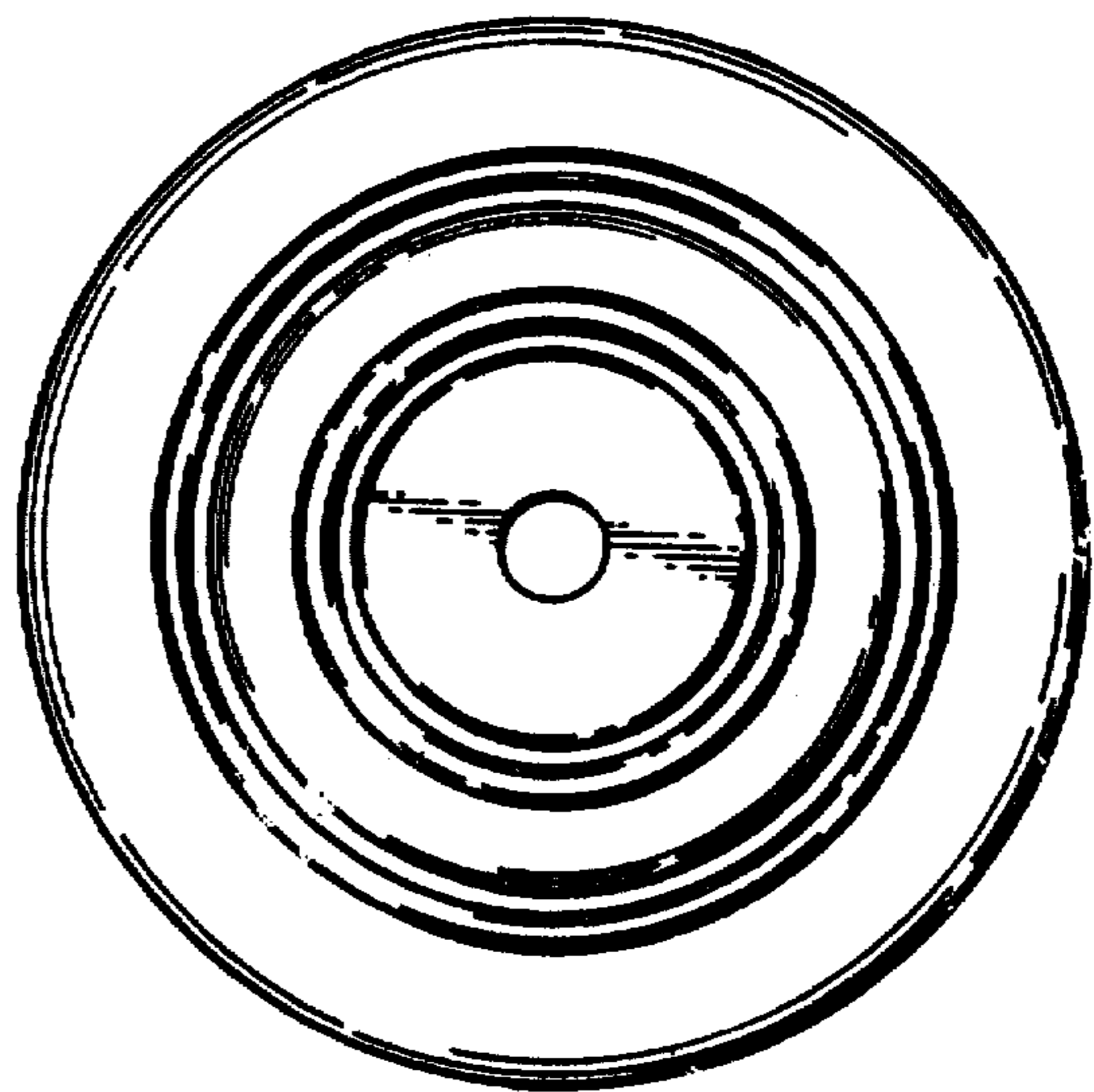

FIG. 4.

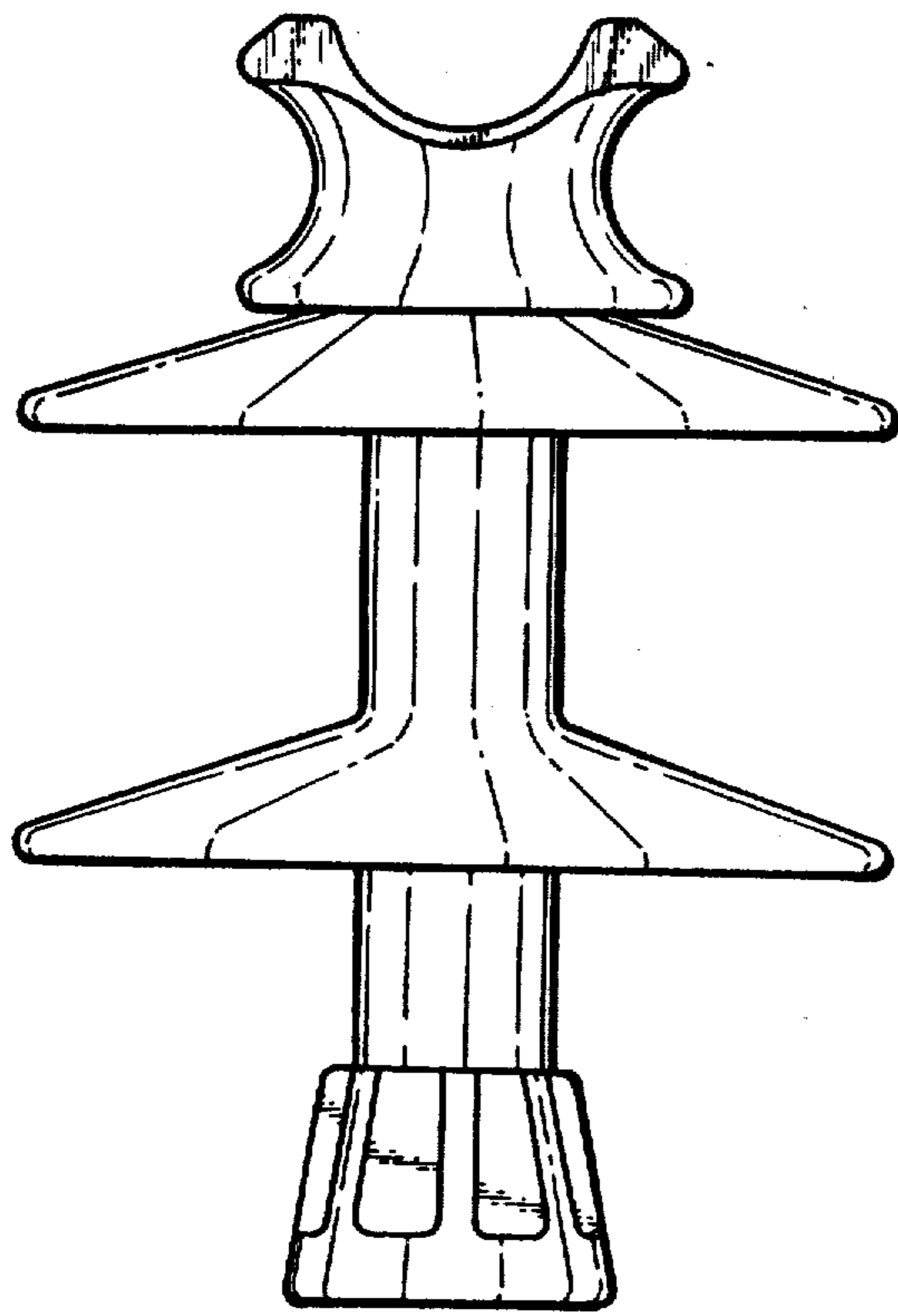

FIG. 5.

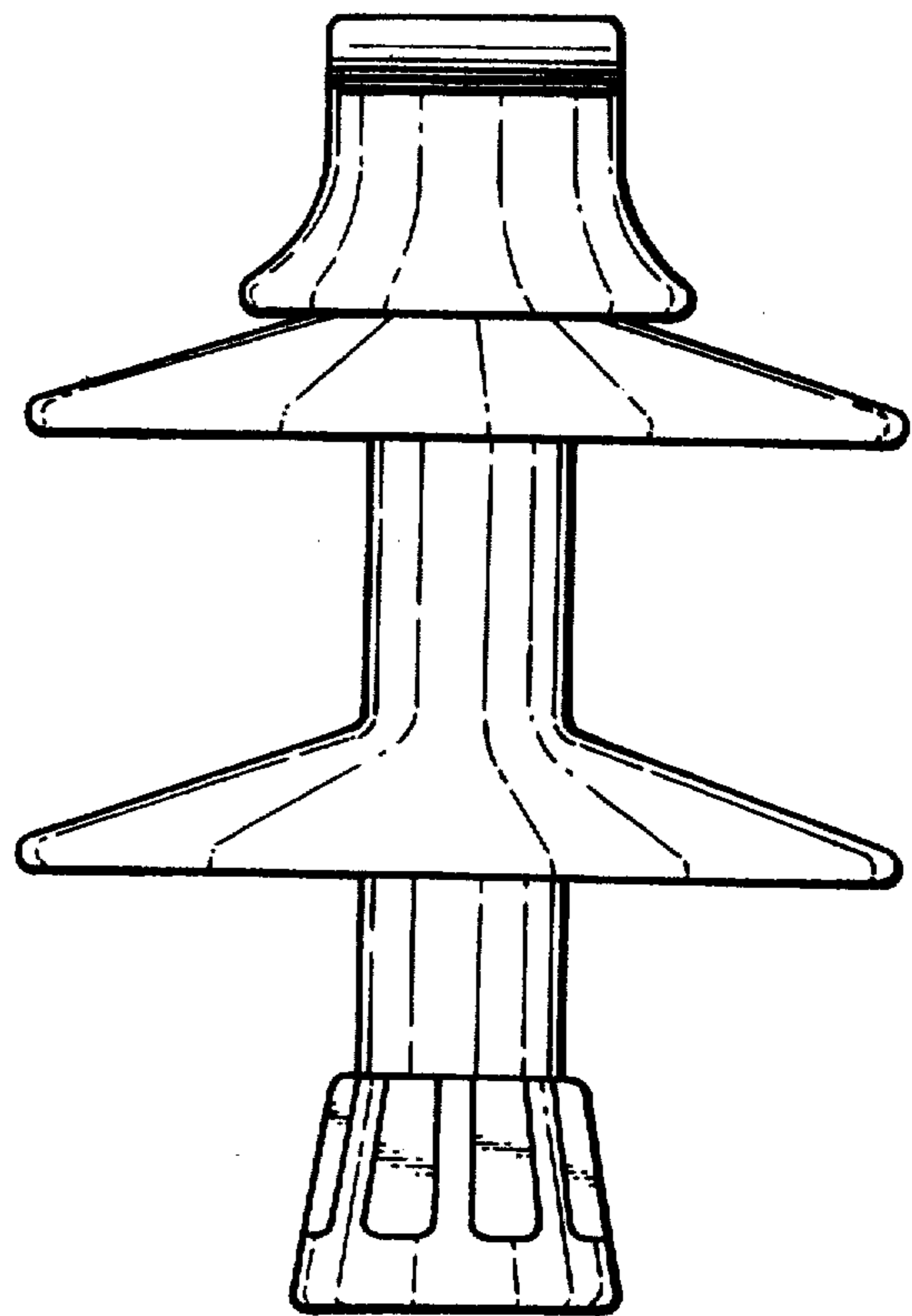

FIG. 6.

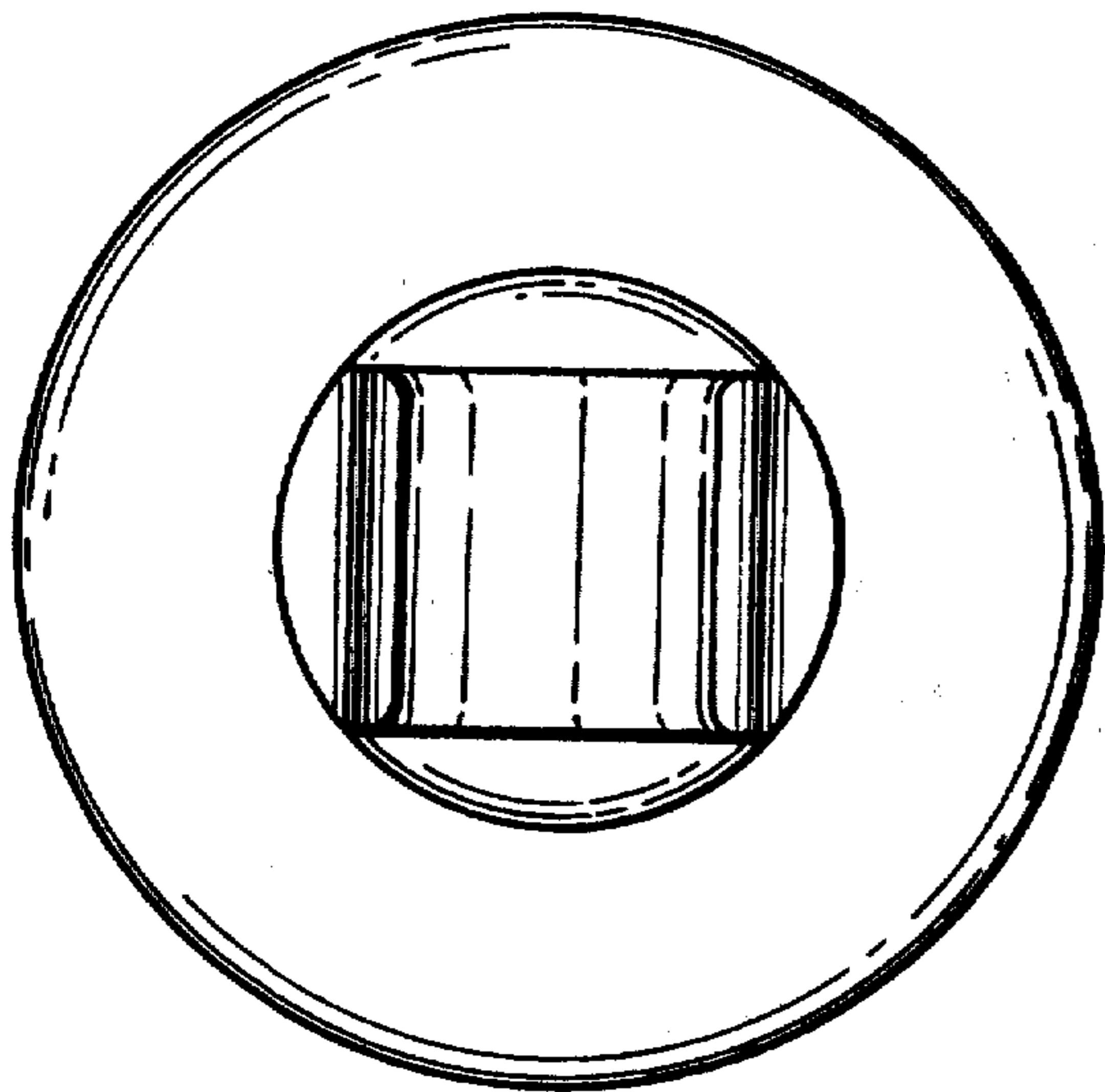

FIG. 7.

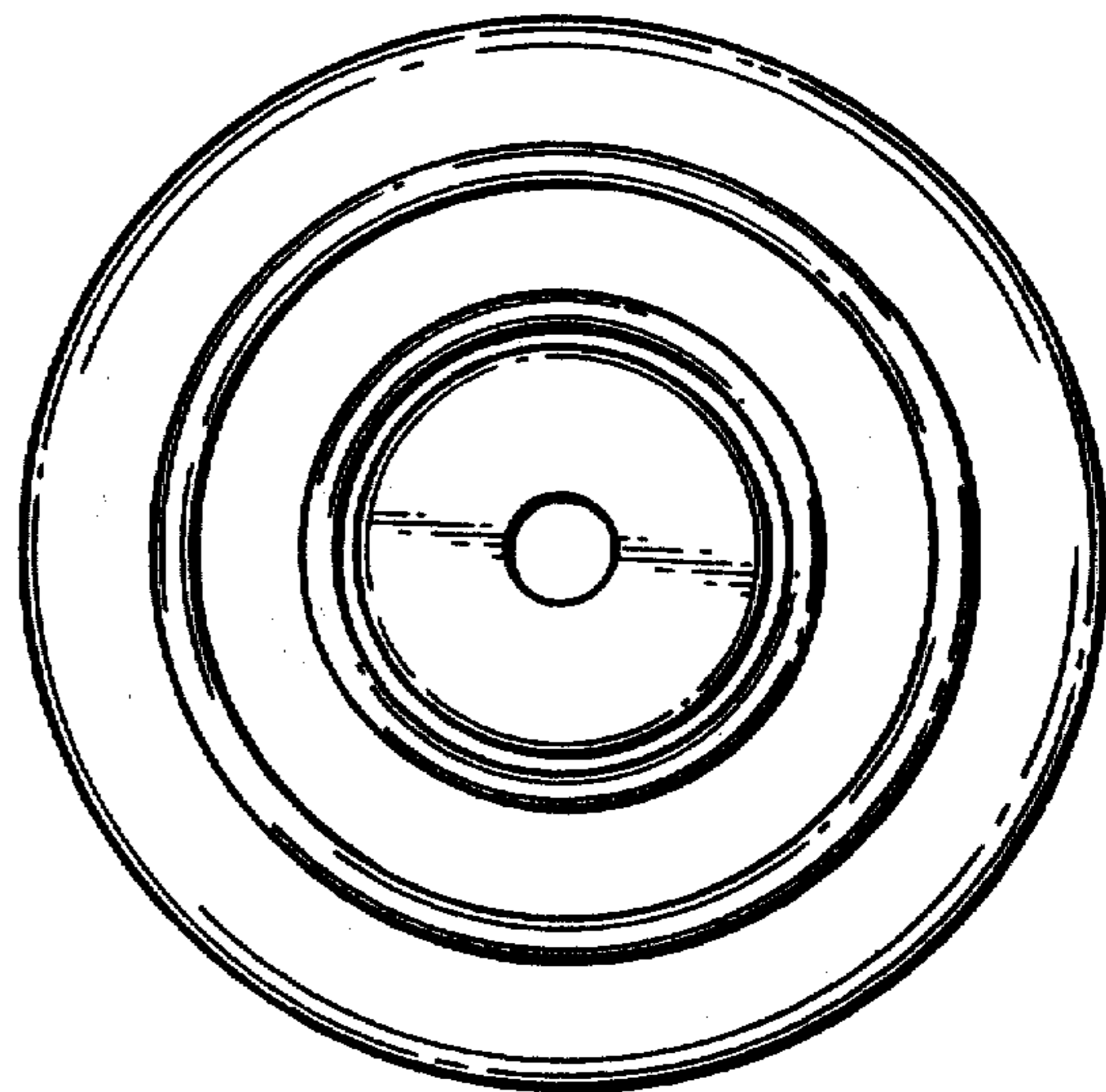

FIG. 8.

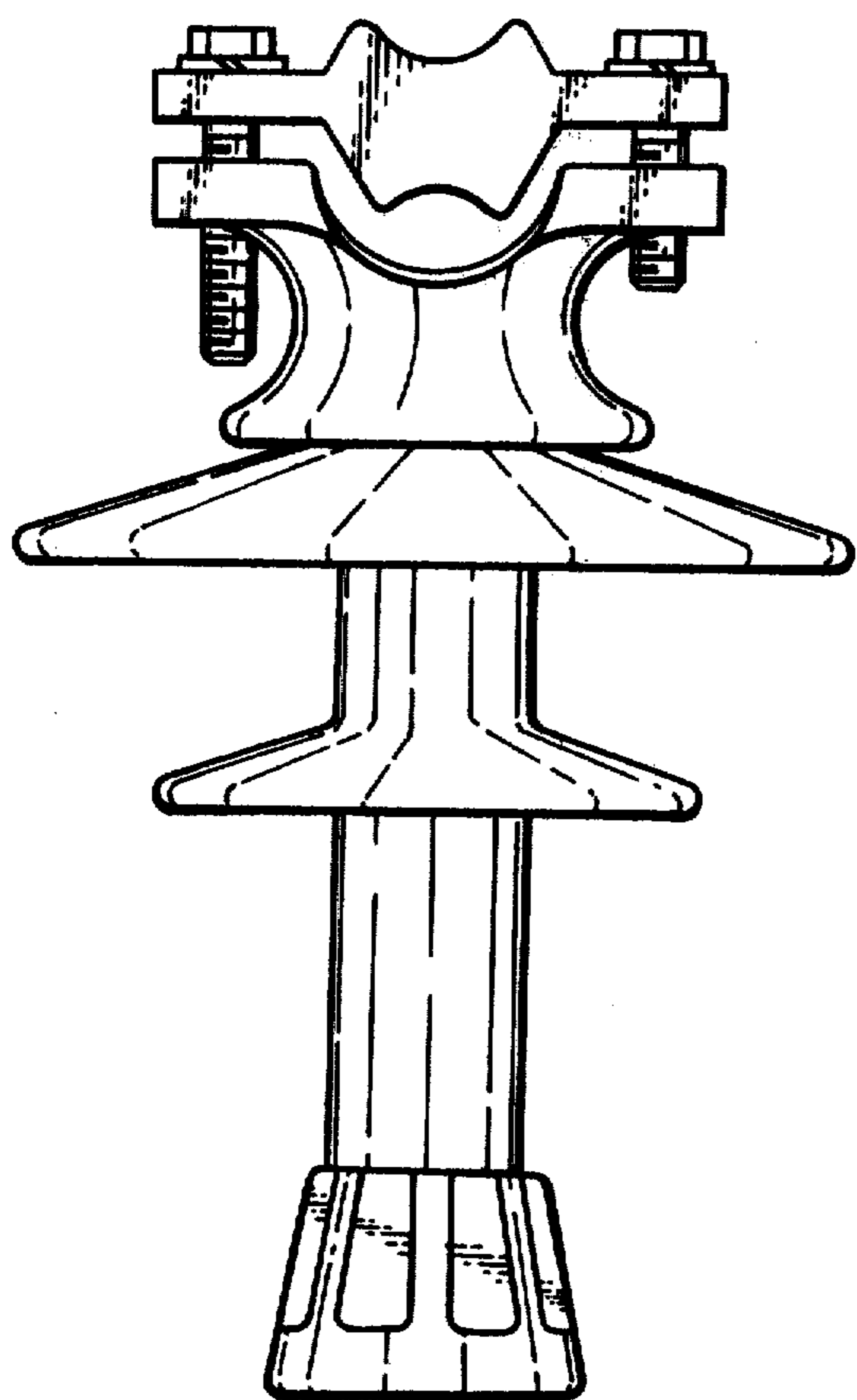

FIG. 9.

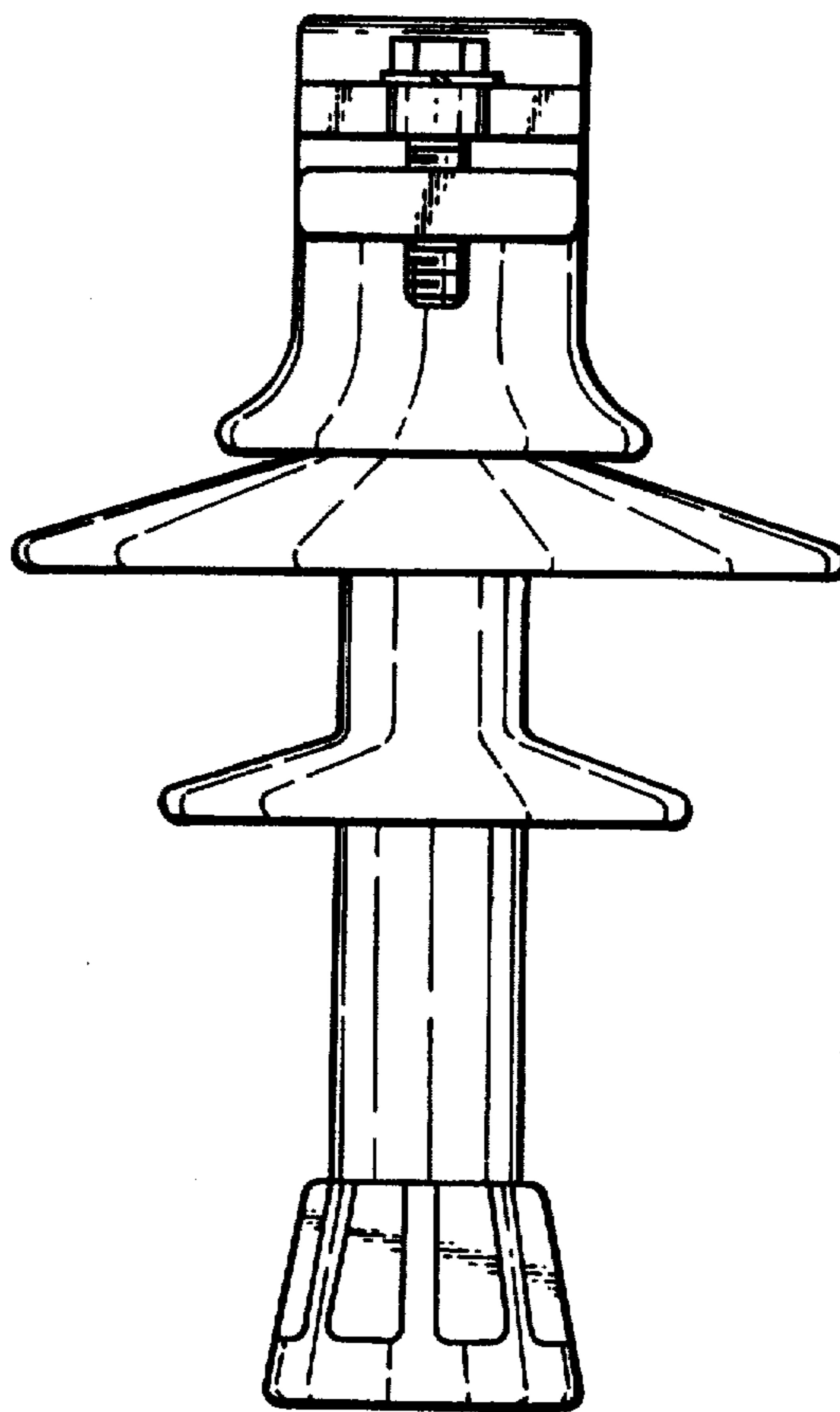

FIG. 10.

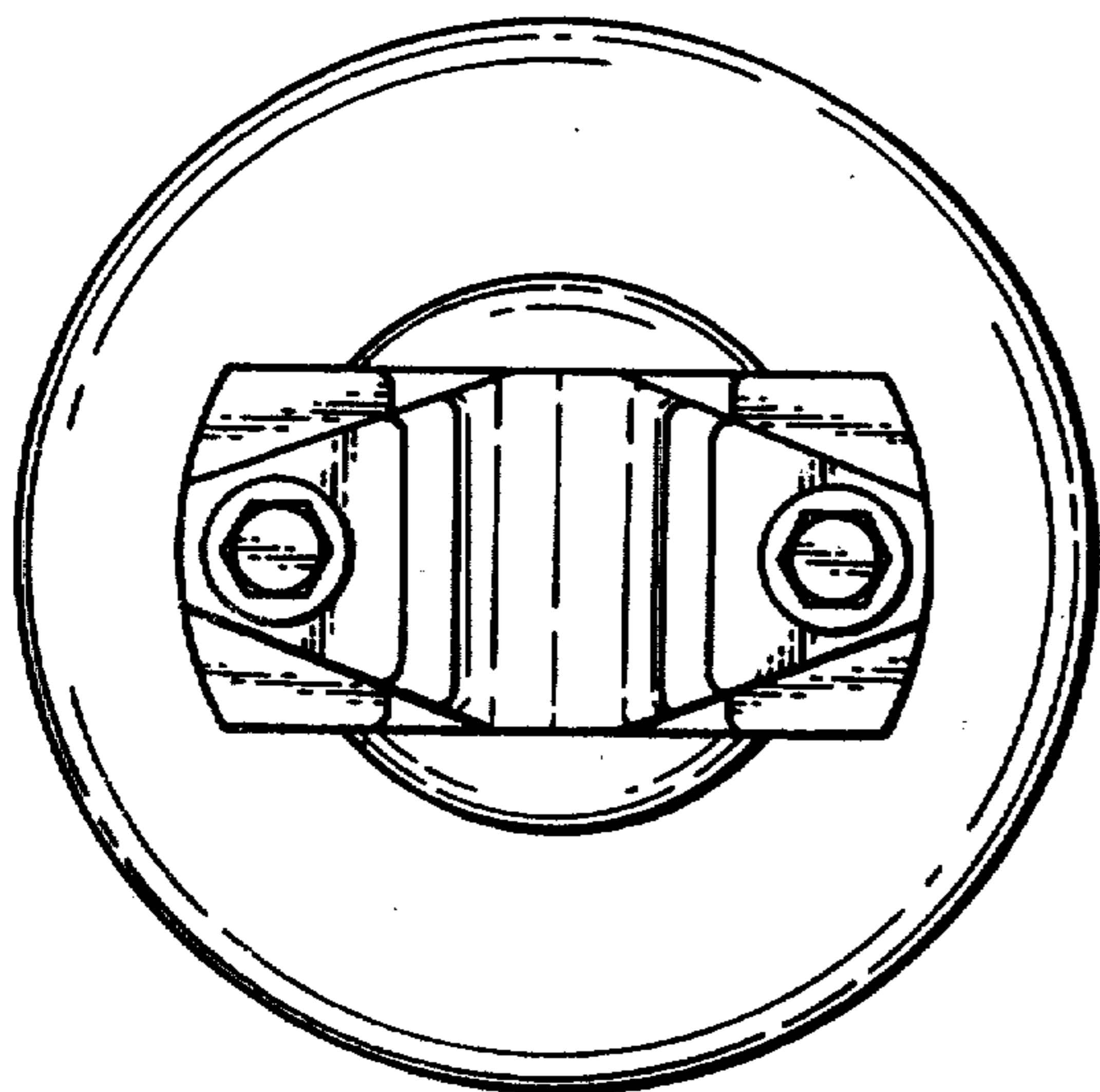

FIG. 11.

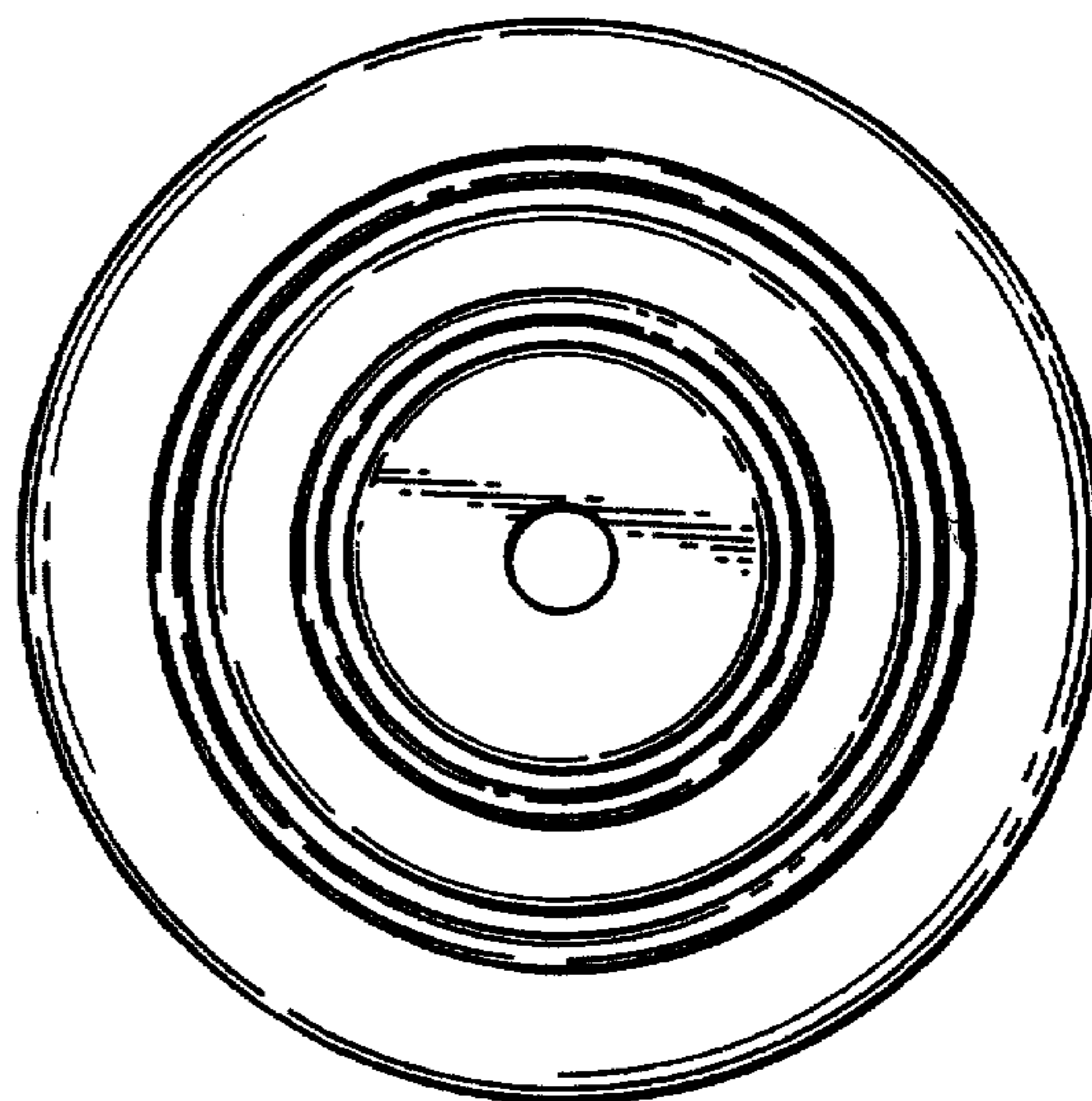

FIG. 12.

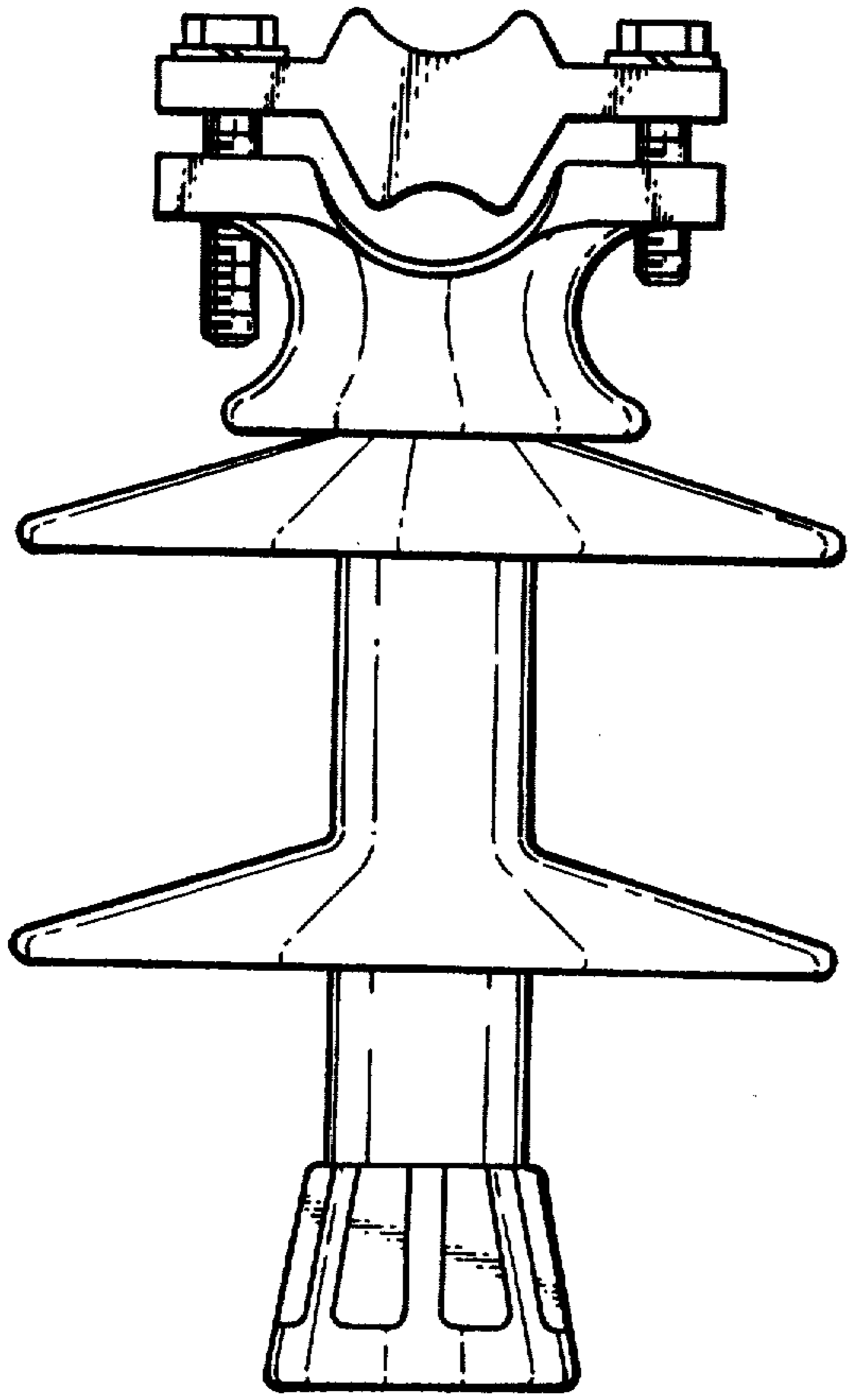

FIG. 13.

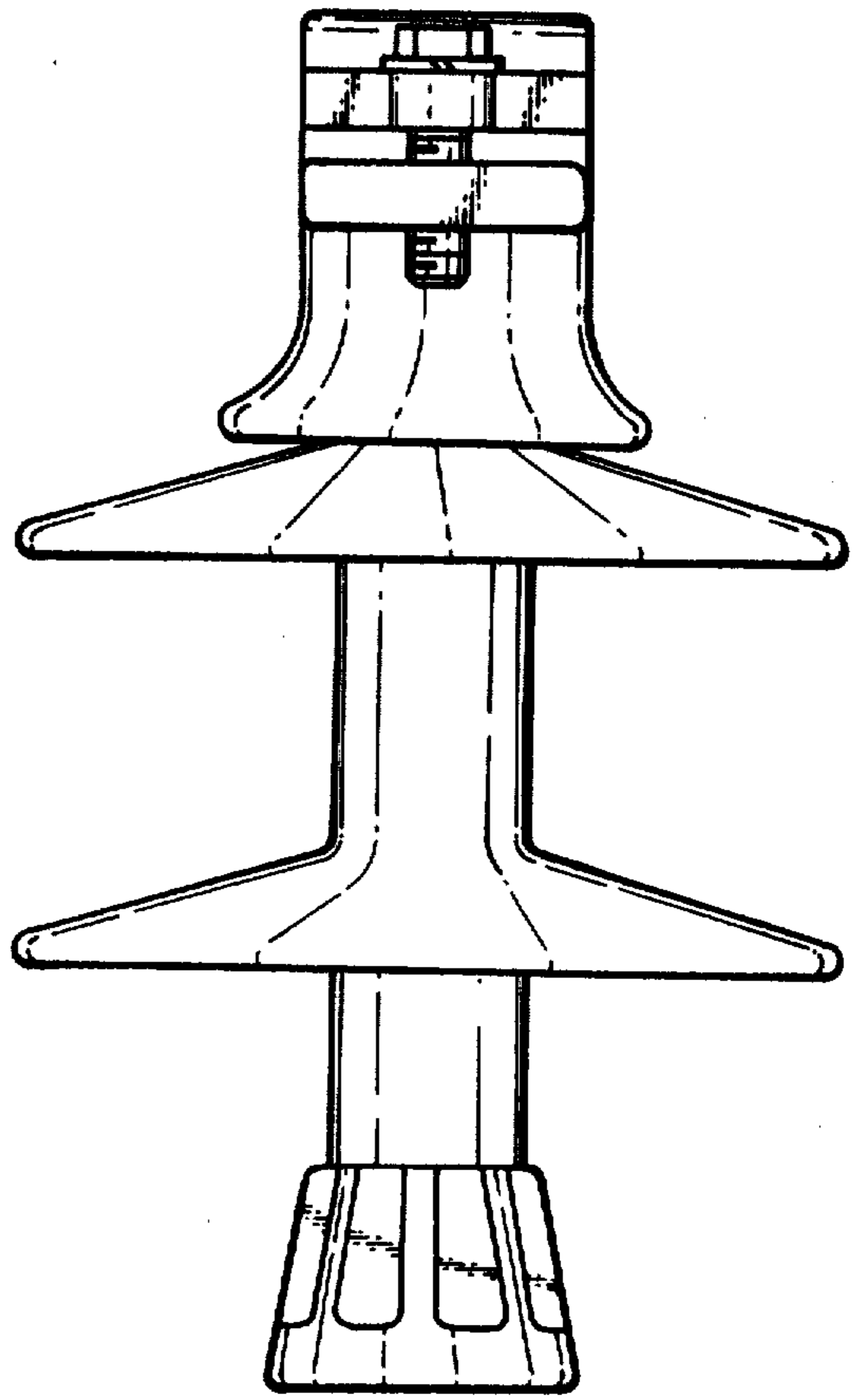

FIG. 14.

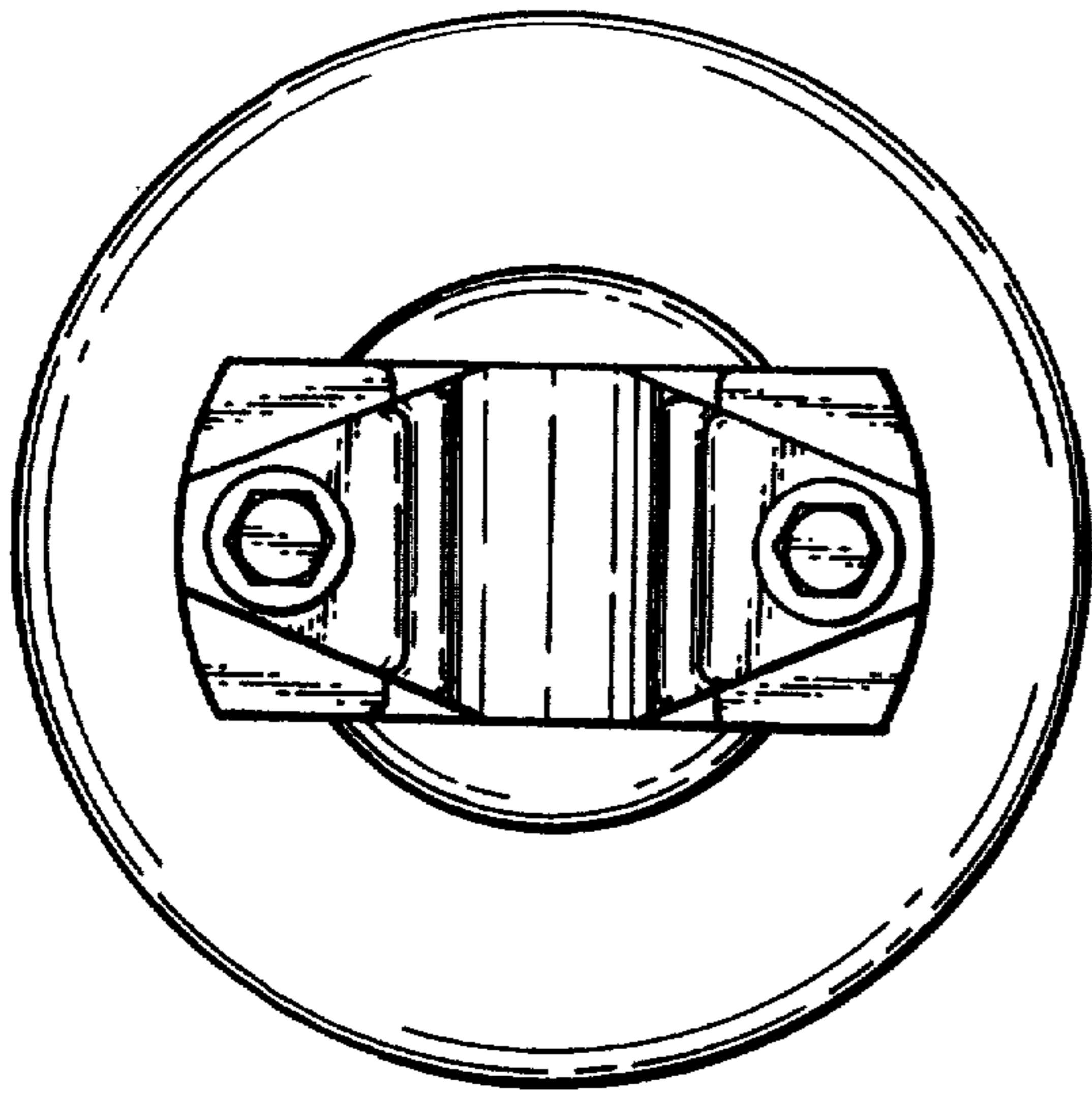

FIG. 15.

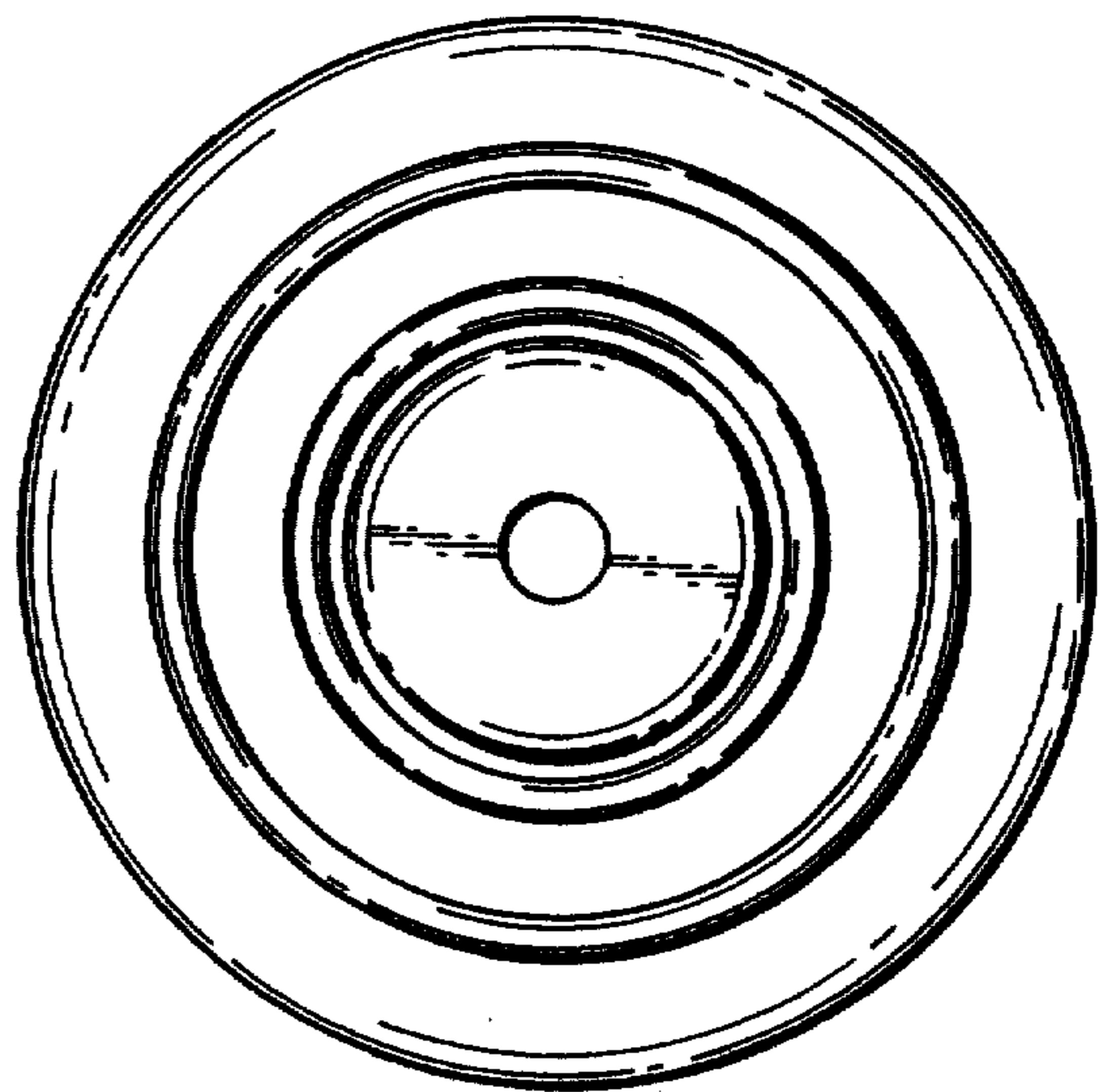

FIG. 16.