

**United States Patent** [19]  
**Badsey**

[11] **Patent Number: Des. 274,609**

[45] **Date of Patent: \*\* Jul. 10, 1984**

[54] **MOTOR VEHICLE**

[76] **Inventor: William J. Badsey, P.O. Box 70061,  
Bryanston 2021, South Africa**

[\*\*] **Term: 14 Years**

[21] **Appl. No.: 292,992**

[22] **Filed: Aug. 14, 1981**

[30] **Foreign Application Priority Data**

Feb. 20, 1981 [ZA] South Africa ..... 81/0129  
[52] **U.S. Cl.** ..... **D12/85; D12/88**  
[58] **Field of Search** ..... **D12/85, 91, 92, 88;  
D21/136, 137; 180/210, 211, 215; 296/15**

[56]

**References Cited**

**U.S. PATENT DOCUMENTS**

D. 185,843 8/1959 James ..... D12/92  
D. 205,998 10/1966 Barris ..... D12/92  
D. 218,814 9/1970 Markham ..... D12/92  
D. 243,595 3/1977 Belz ..... D12/91

*Primary Examiner*—James M. Gandy  
*Attorney, Agent, or Firm*—Fred Wiviott

[57]

**CLAIM**

The ornamental design for a motor vehicle, as shown and described.

**DESCRIPTION**

FIG. 1 is a front elevational view of a motor vehicle showing my new design;  
FIG. 2 is a rear elevational view thereof;  
FIG. 3 is a top plan view thereof;  
FIG. 4 is a side elevational view thereof, the opposite being a mirror image of that shown; and  
FIG. 5 is an isometric view thereof.

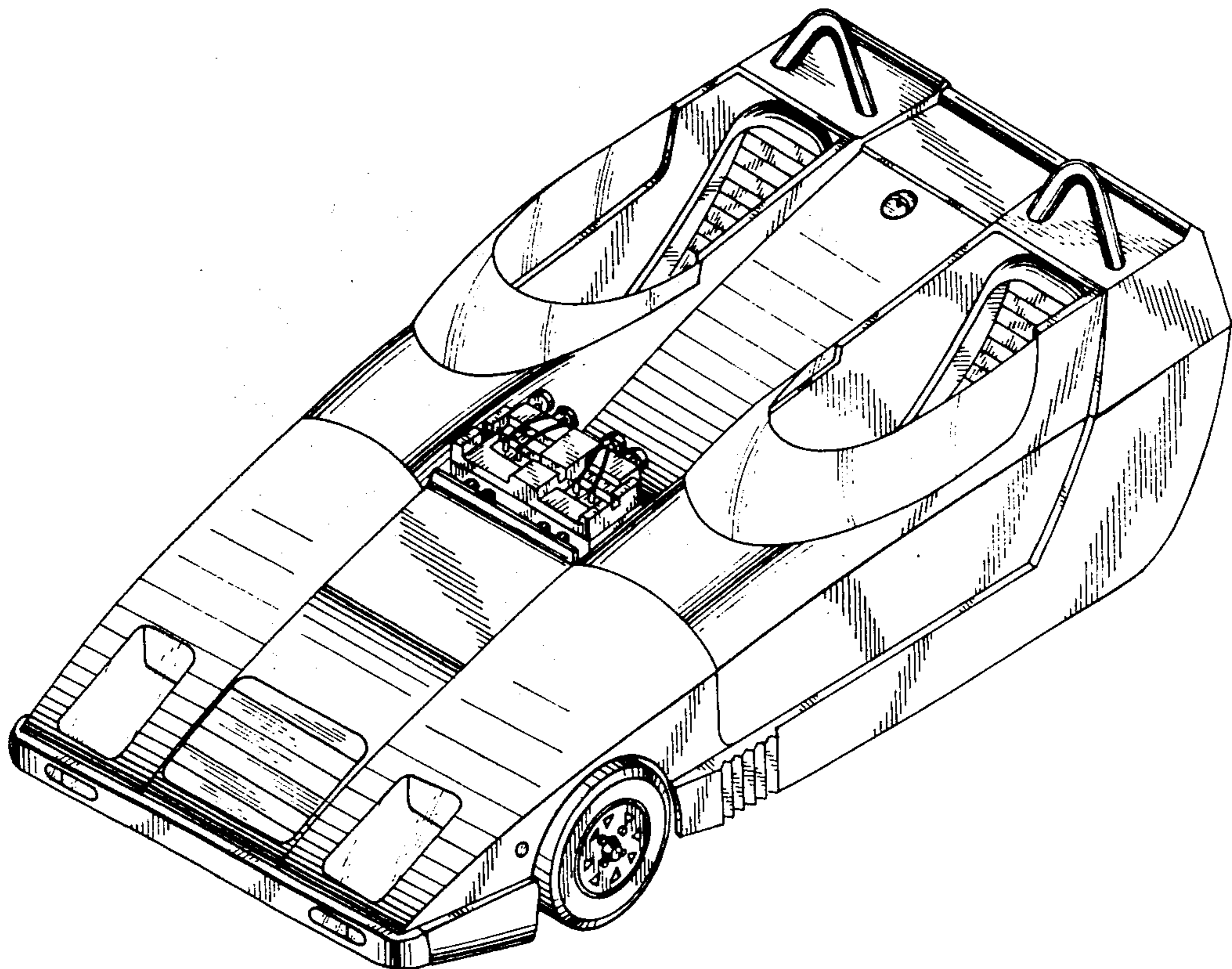

FIG. 1

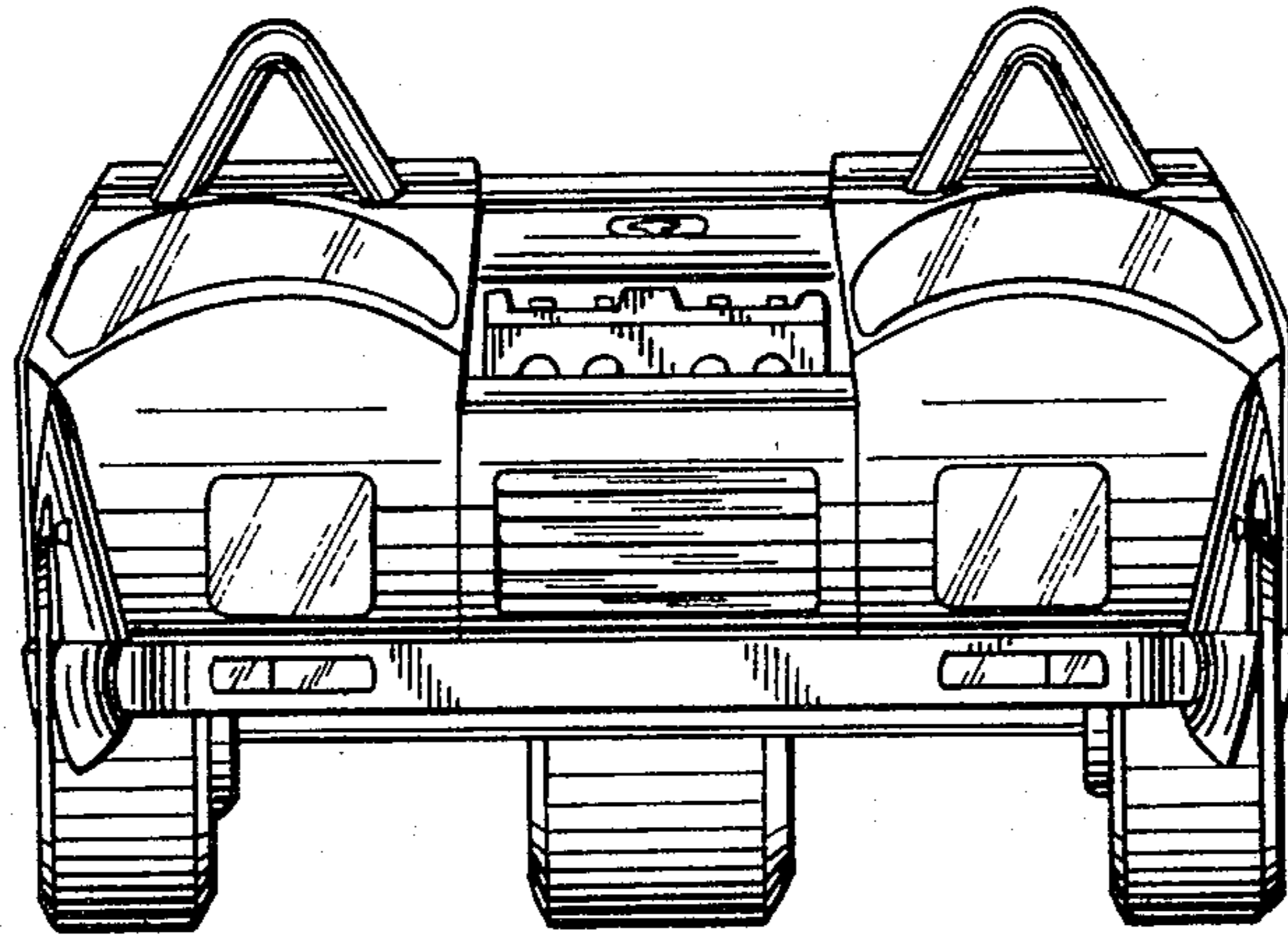

FIG. 2

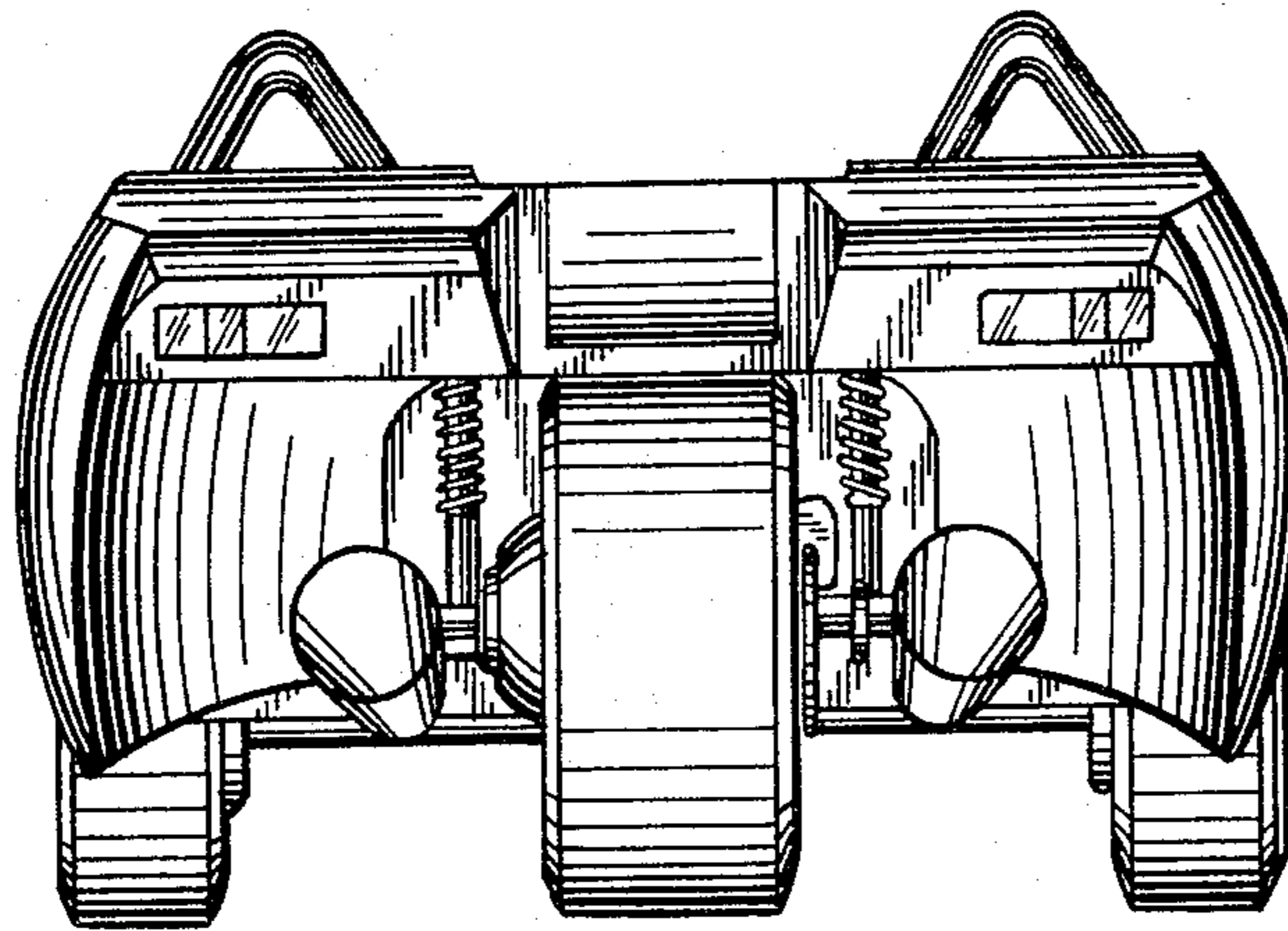

FIG. 3

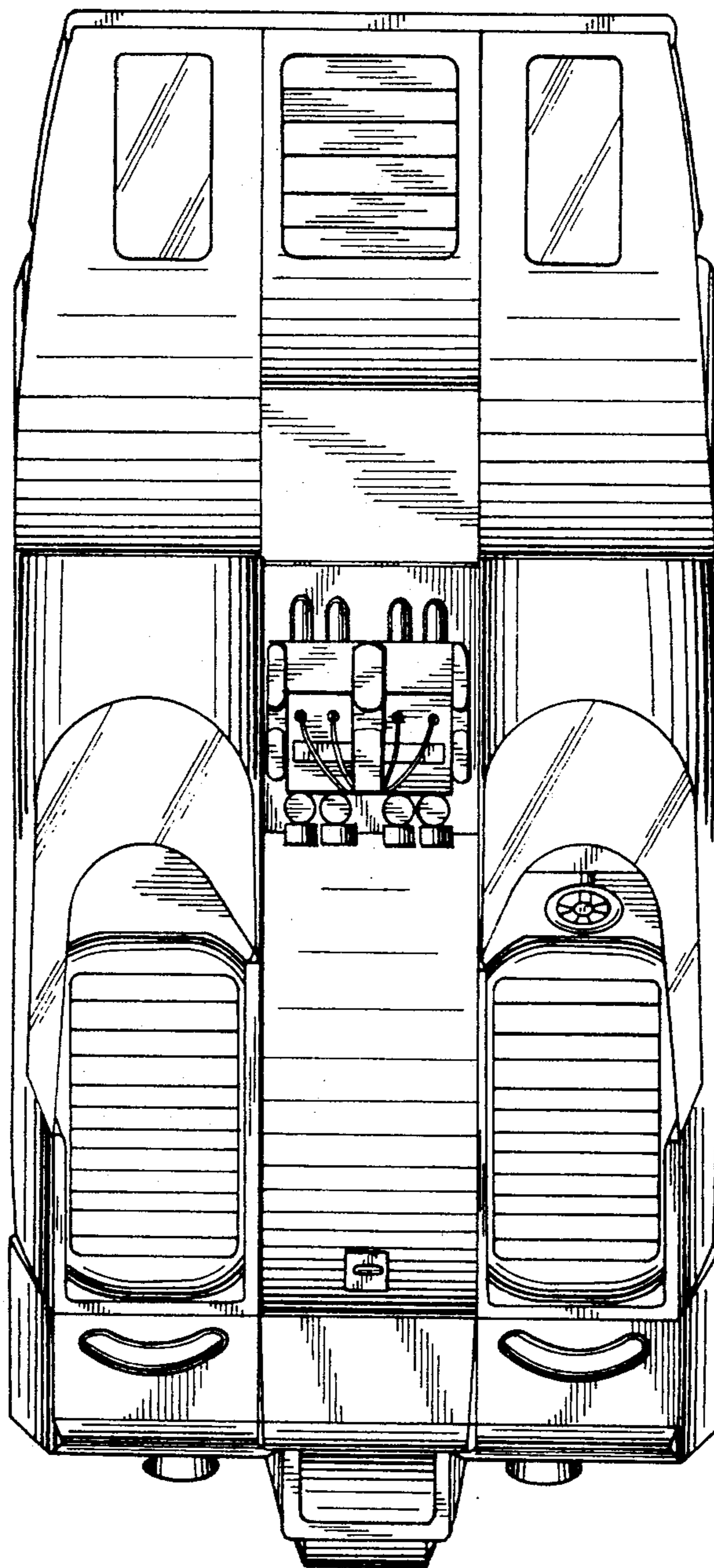
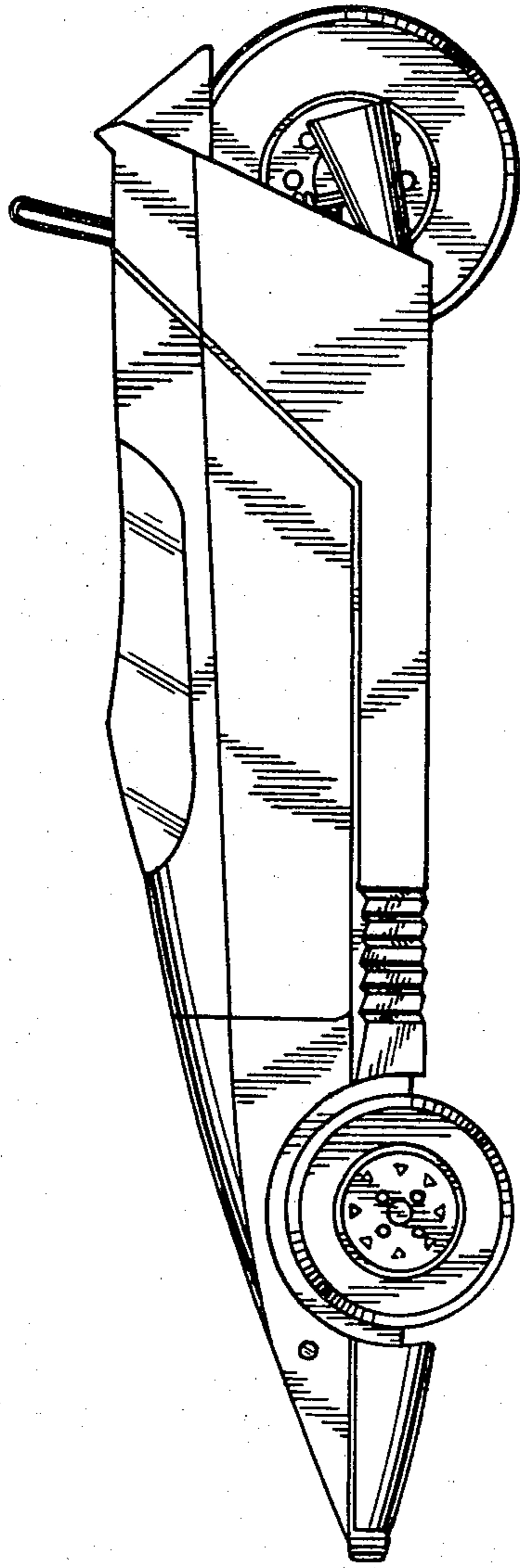

FIG. 4



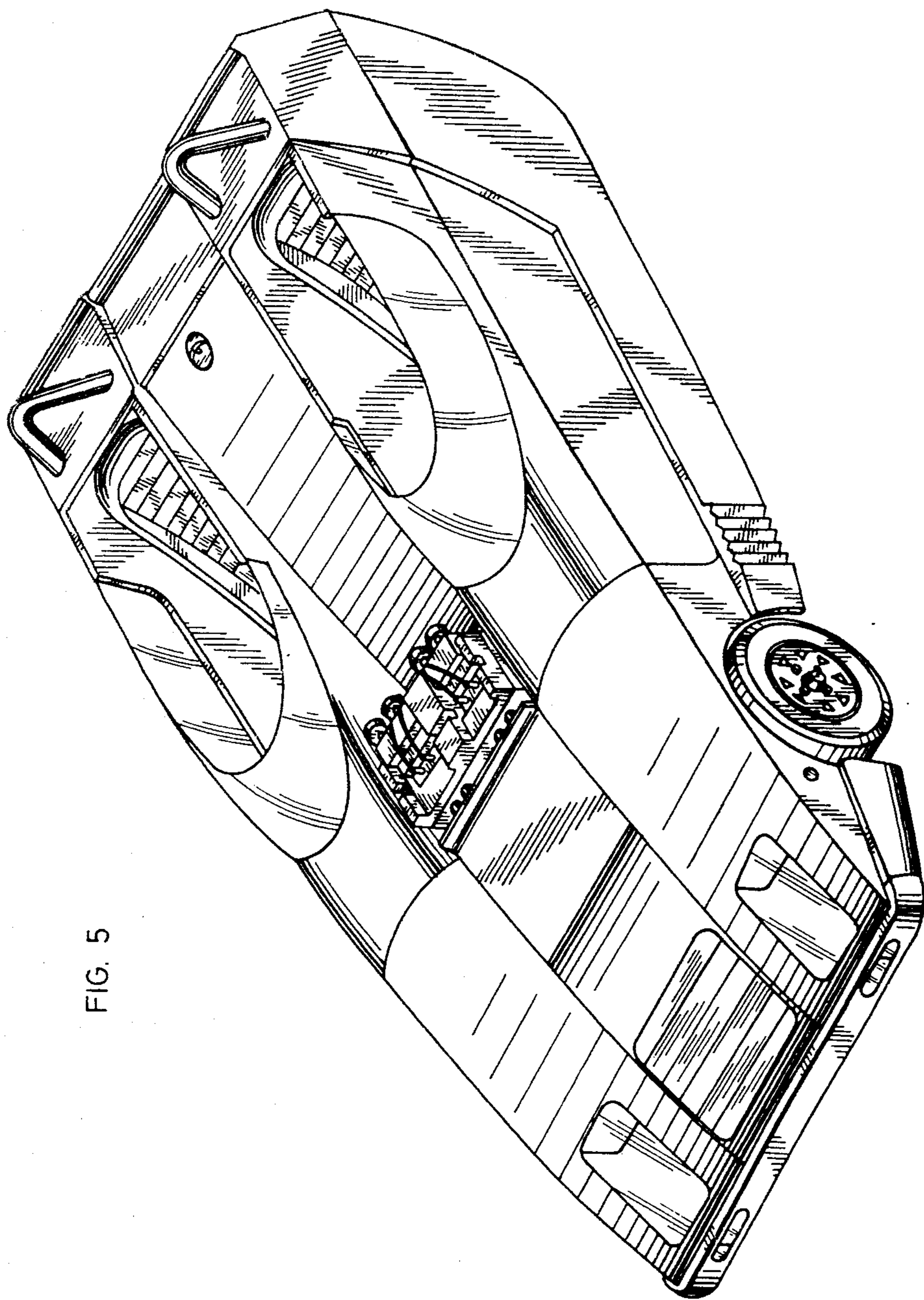

FIG. 5