

[54] **COMBINED CAP AND ADAPTER RING FOR A FUEL TANK**

[75] **Inventor: James R. Shaw, Amagansett, N.Y.**

[73] **Assignee: Shaw Aero Devices, Inc., East Hampton, N.Y.**

[**] **Term: 14 Years**

[21] **Appl. No.: 318,426**

[22] **Filed: Nov. 5, 1981**

[52] **U.S. Cl. D23/1; D9/454; D12/197**

[58] **Field of Search D23/1, 2; D9/454; D12/197; 220/238, 243, 293, 295, 298, 300-304, DIG. 32, DIG. 33**

[56] **References Cited**

U.S. PATENT DOCUMENTS

D. 264,578	5/1982	Gaston	D12/197
D. 265,848	8/1982	Johansson	D23/1
2,570,818	10/1951	Kirkbride et al. .	
2,597,576	5/1952	Donovan	220/293 X
3,006,499	10/1961	Corbett .	
3,151,845	10/1964	Lpuze .	
3,173,570	3/1965	De Pew	220/301
3,276,615	10/1966	De Pew	220/246
3,280,372	10/1966	De Pew	220/200 X
3,391,817	7/1968	Shaw	220/251 X
3,476,285	11/1969	De Pew	220/251 X
3,557,993	1/1971	De Pew	220/251
4,132,327	1/1979	Van Dyke et al.	220/251 X

Primary Examiner—James R. Largen
Attorney, Agent, or Firm—Pennie & Edmonds

[57] **CLAIM**

The ornamental design for a combined cap and adapter ring for a fuel tank, as shown.

DESCRIPTION

FIG. 1 is a top plan view of a combined cap and adapter ring for a fuel tank showing my new design; FIG. 2 is another top plan view thereof, showing the handle in an open position; FIG. 3 is a right side elevational view of FIG. 1; FIG. 4 is a right side elevational view of FIG. 2; FIG. 5 is a front elevational view of FIG. 1; FIG. 6 is a front elevational view of FIG. 2; FIG. 7 is a left side elevational view of FIG. 1; FIG. 8 is a left side elevational view of FIG. 2; FIG. 9 is a rear elevational view of FIG. 1; FIG. 10 is a rear elevational view of FIG. 2; FIG. 11 is a bottom plan view thereof; FIG. 12 is a fragmentary cross sectional view taken on line 12—12 of FIG. 11; FIG. 13 is a top plan view of the cap portion thereof; FIG. 14 is another top plan view of the cap portion thereof, showing the handle in an open position; FIG. 15 is a right side elevational view of FIG. 13; FIG. 16 is a right side elevational view of FIG. 14; FIG. 17 is a front elevational view of FIG. 13; FIG. 18 is a front elevational view of FIG. 14; FIG. 19 is a left side elevational view of FIG. 13; FIG. 20 is a left side elevational view of FIG. 14; FIG. 21 is a rear elevational view of FIG. 13; FIG. 22 is a rear elevational view of FIG. 14; FIG. 23 is a bottom plan view of FIG. 13; FIG. 24 is a top plan view of the adaptor ring portion thereof; FIG. 25 is a right side elevational view of FIG. 24; FIG. 26 is a front elevational view of FIG. 24; FIG. 27 is a left side elevational view of FIG. 24; FIG. 28 is a rear elevational view of FIG. 24; and FIG. 29 is a bottom plan view of FIG. 24.

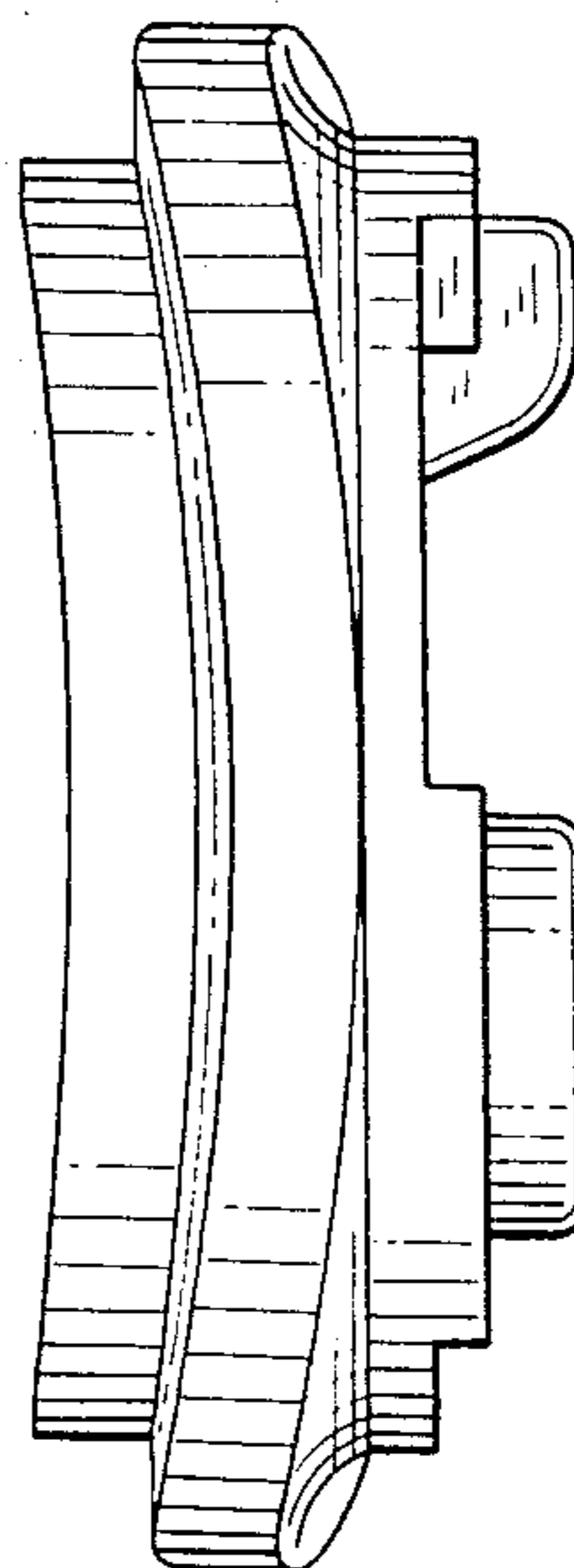
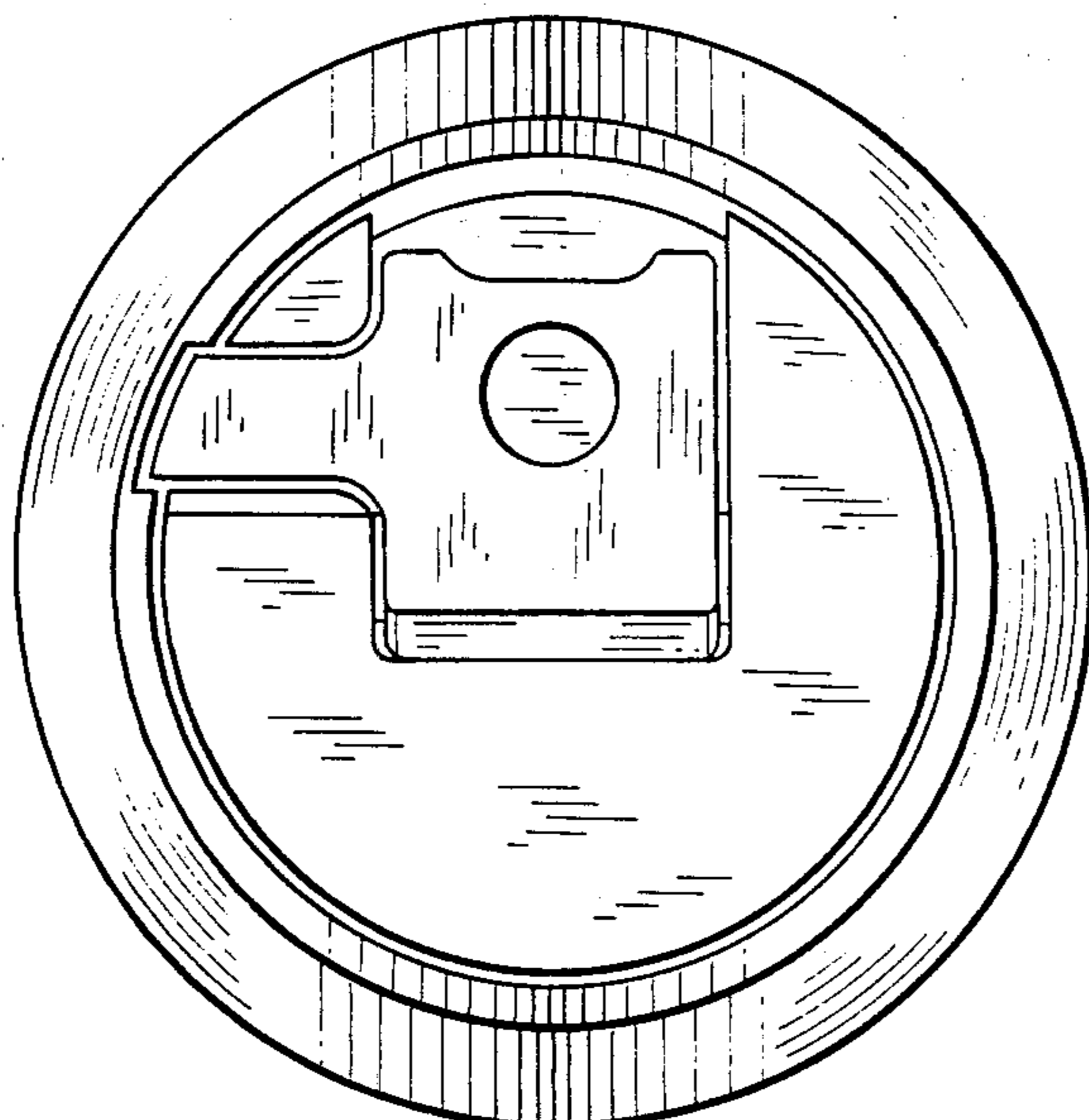

FIG.1

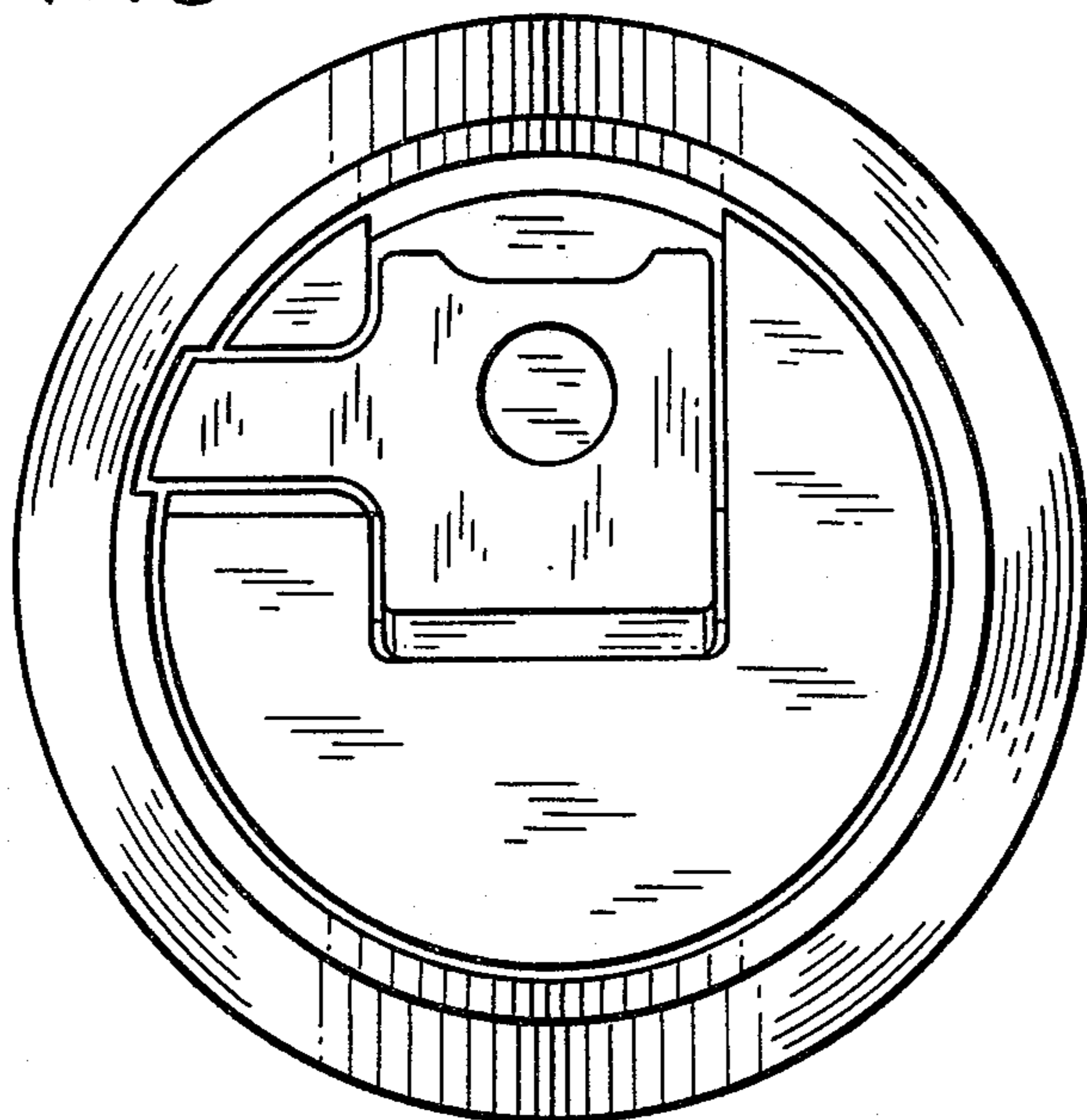

FIG.3

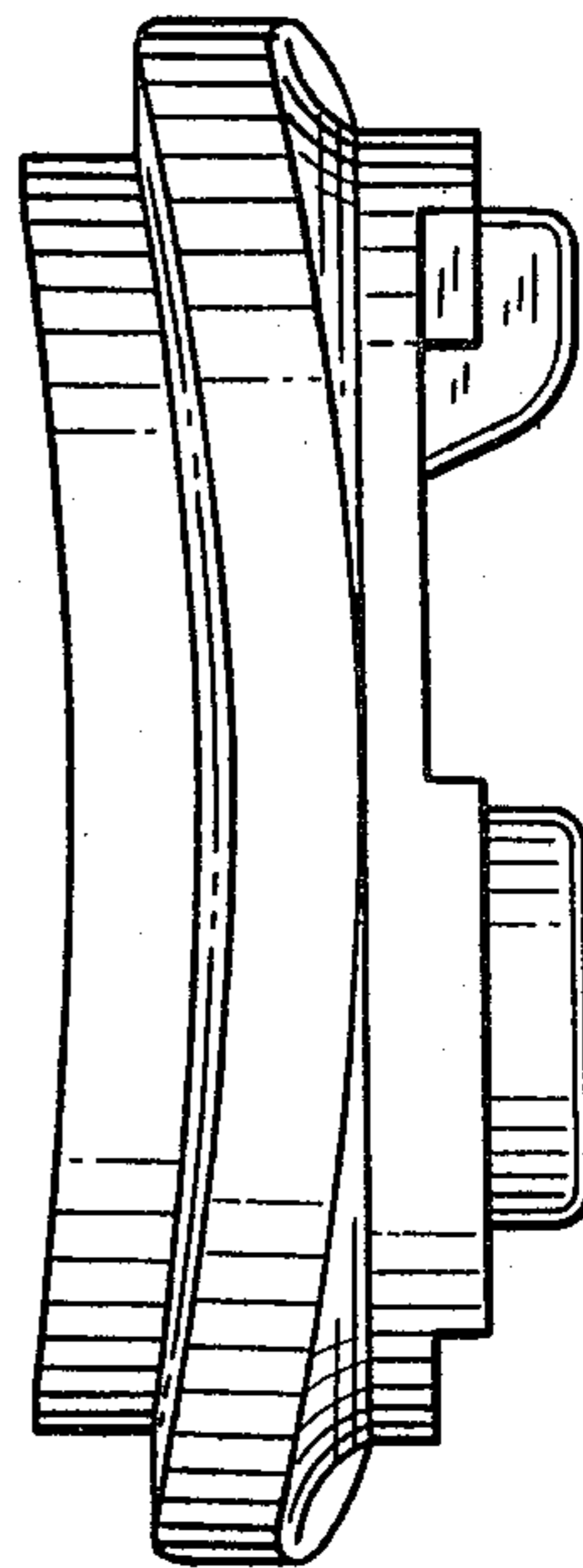

FIG.2

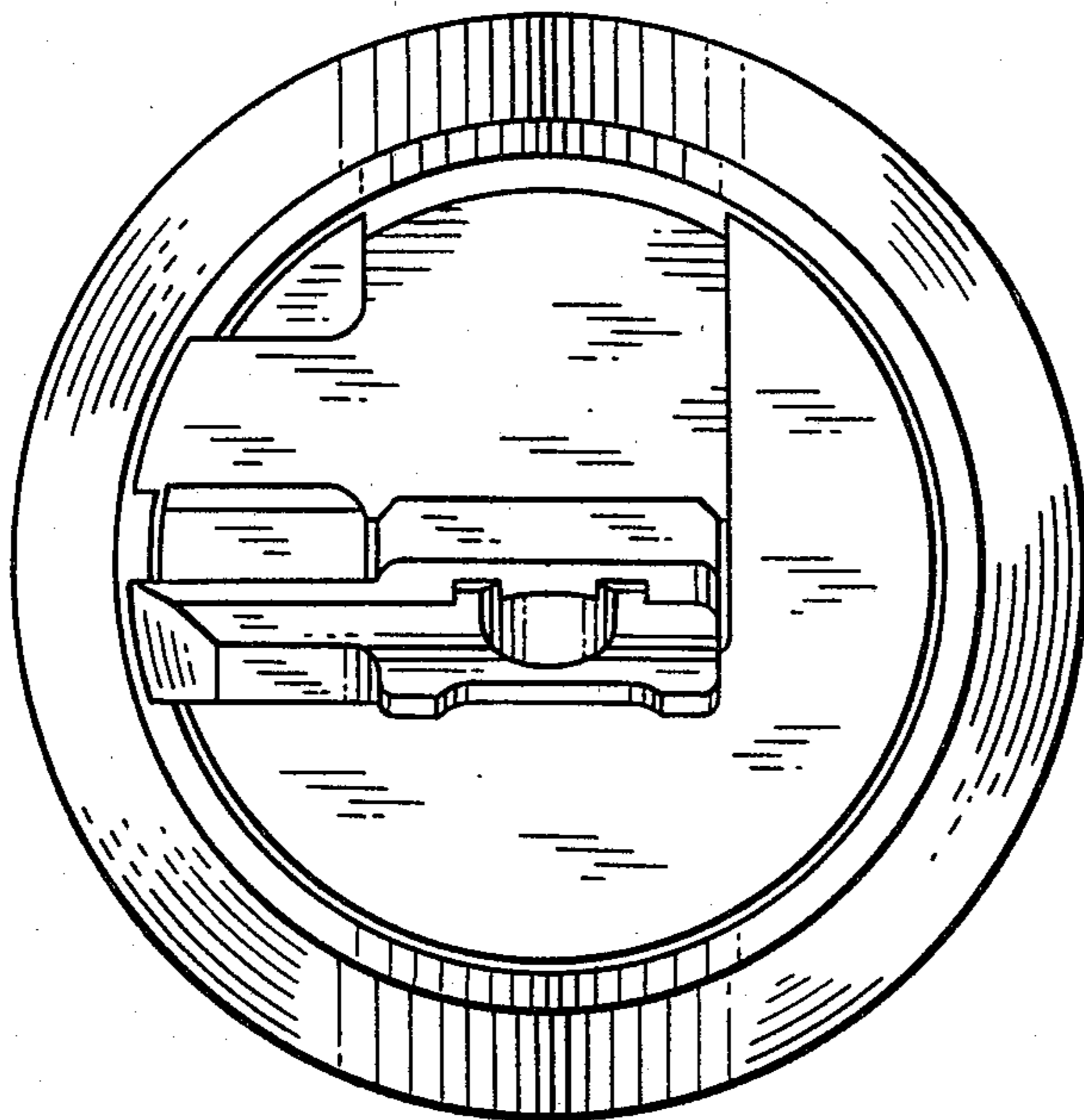

FIG.4

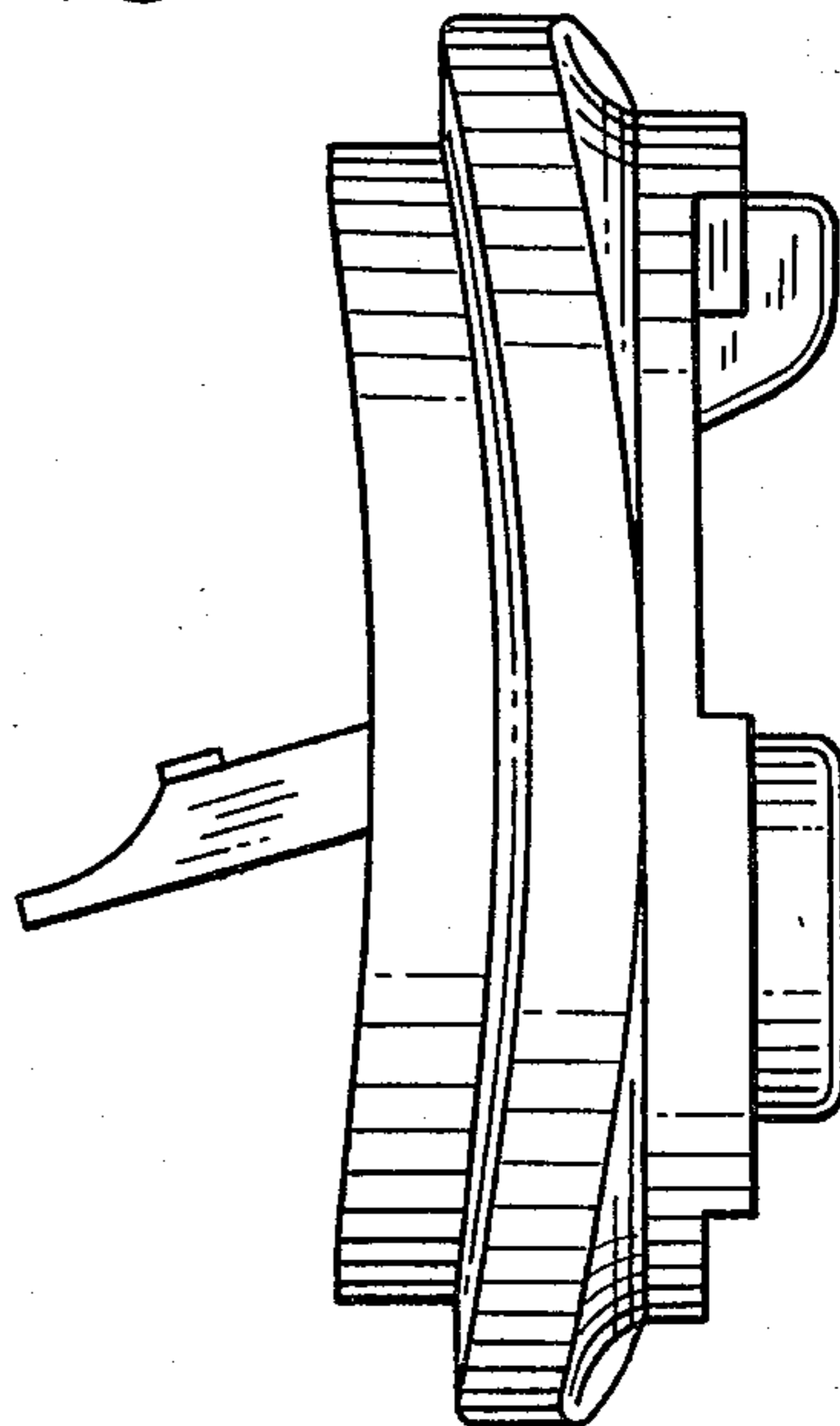

FIG.7

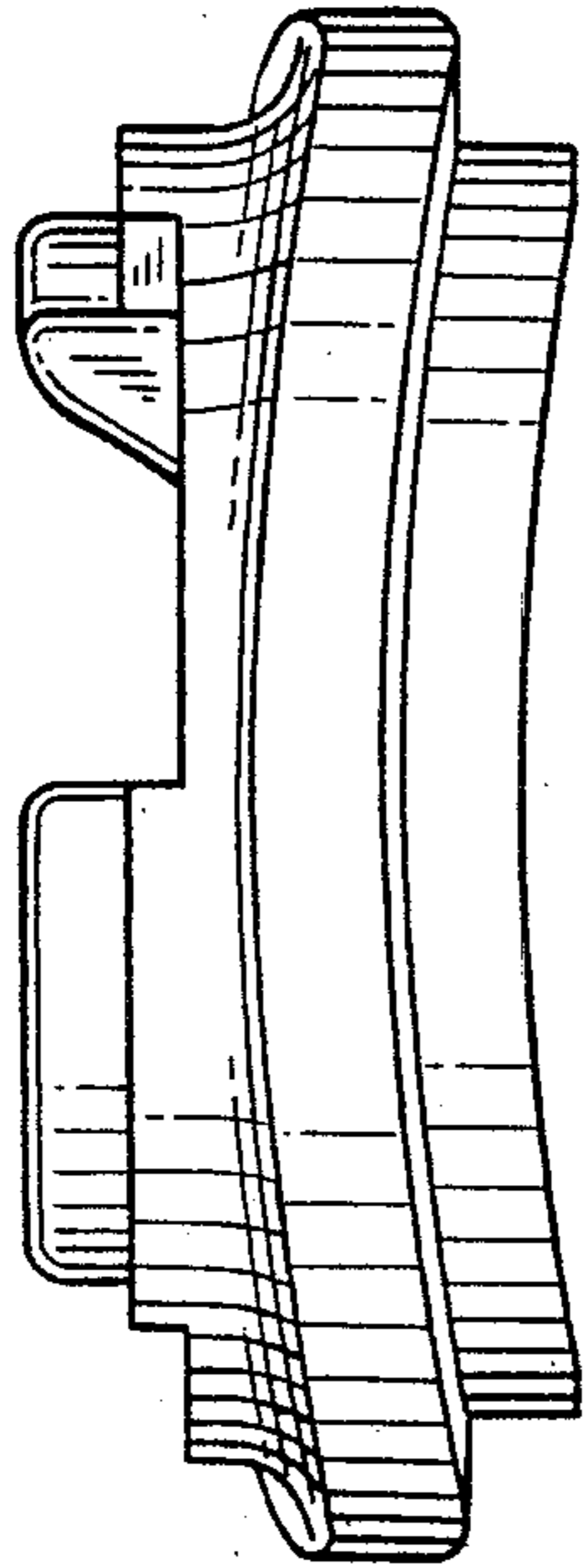

FIG.5

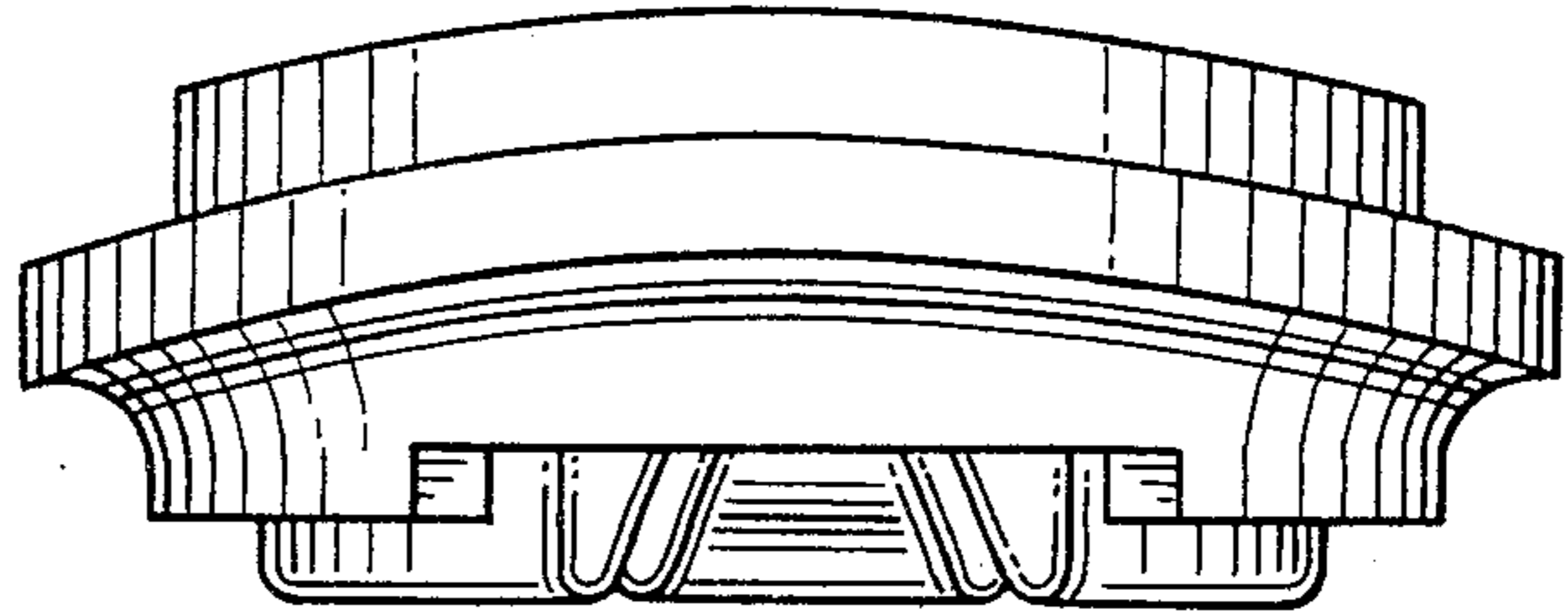

FIG.6

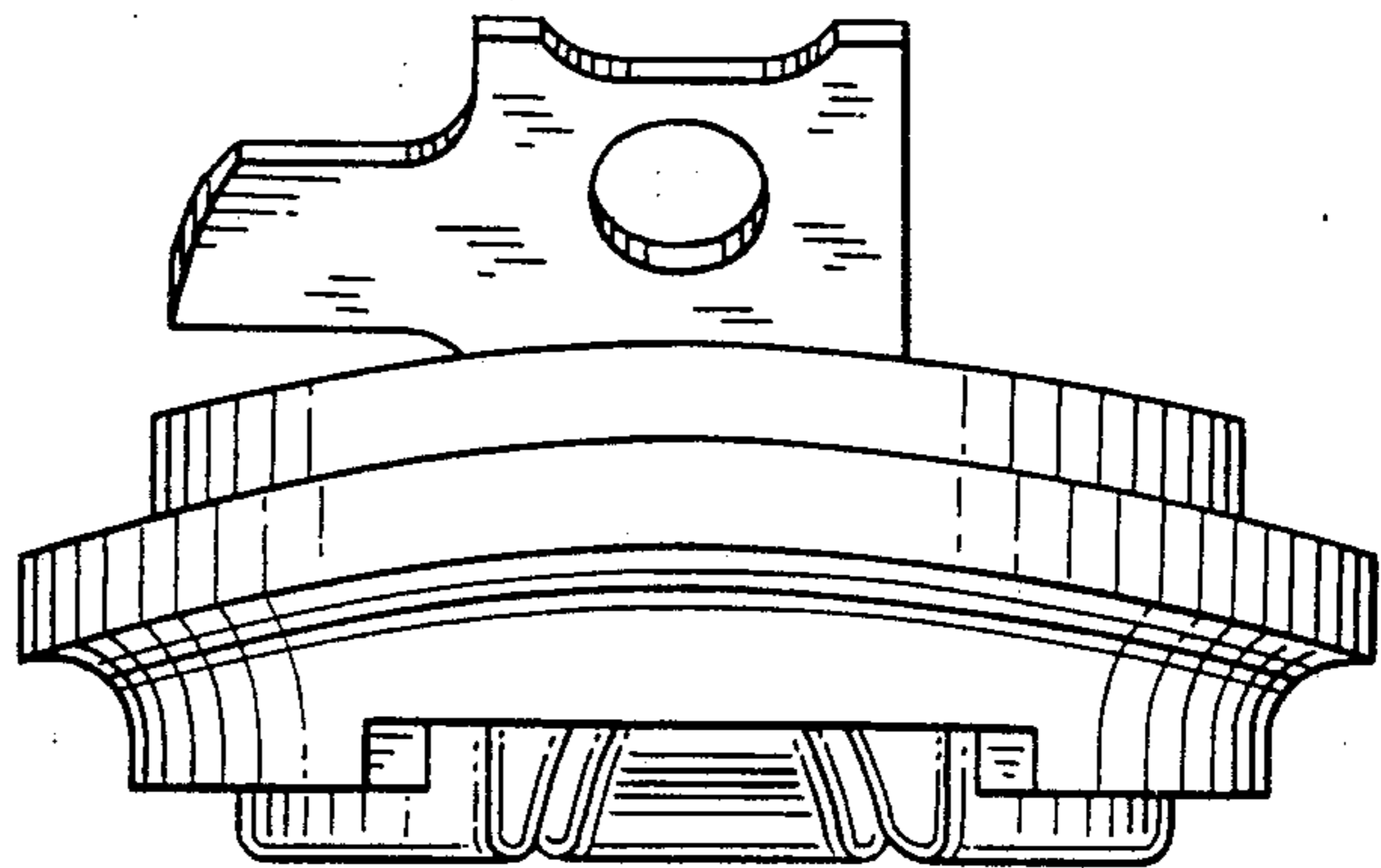

FIG.8

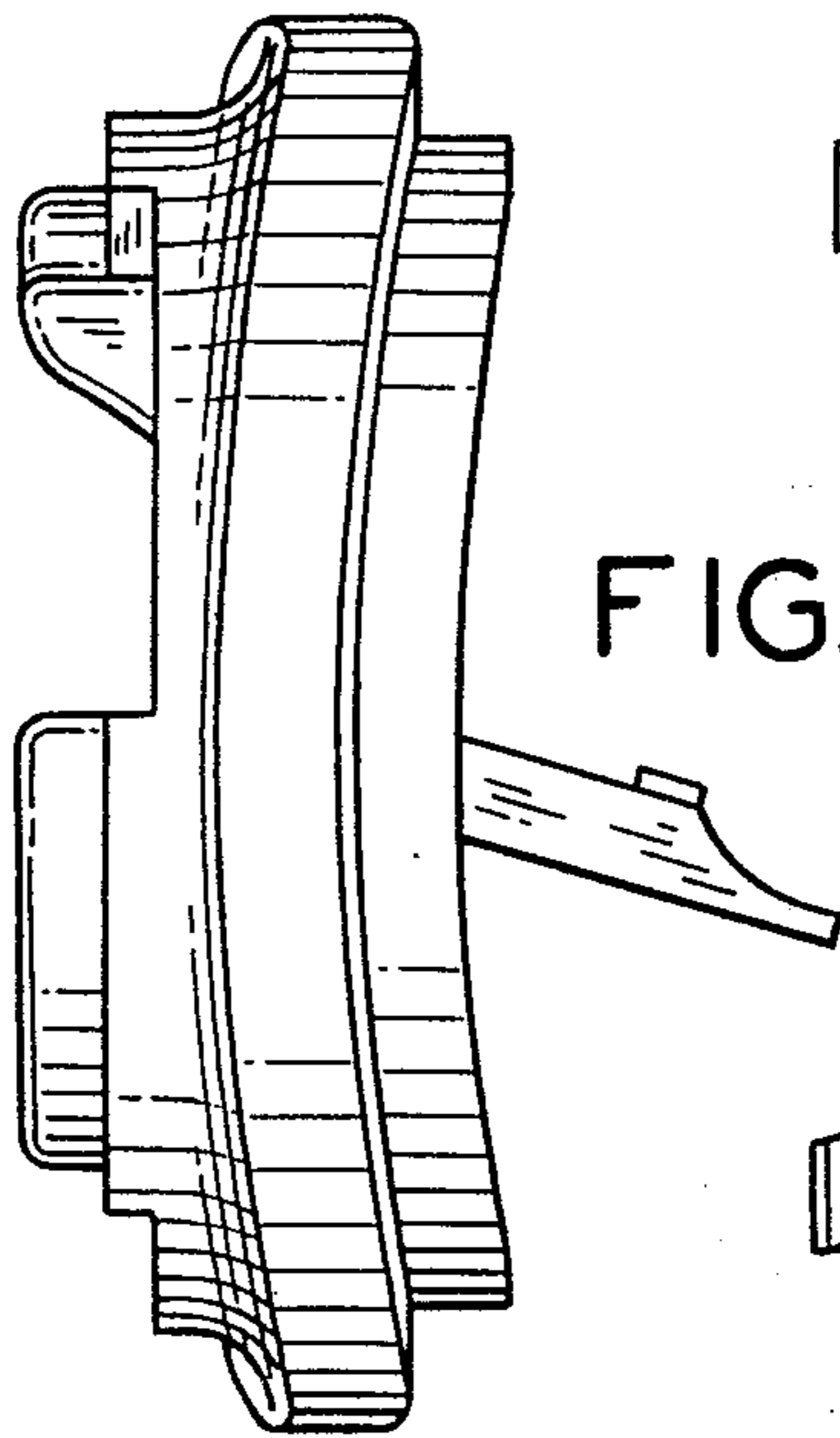

FIG.9

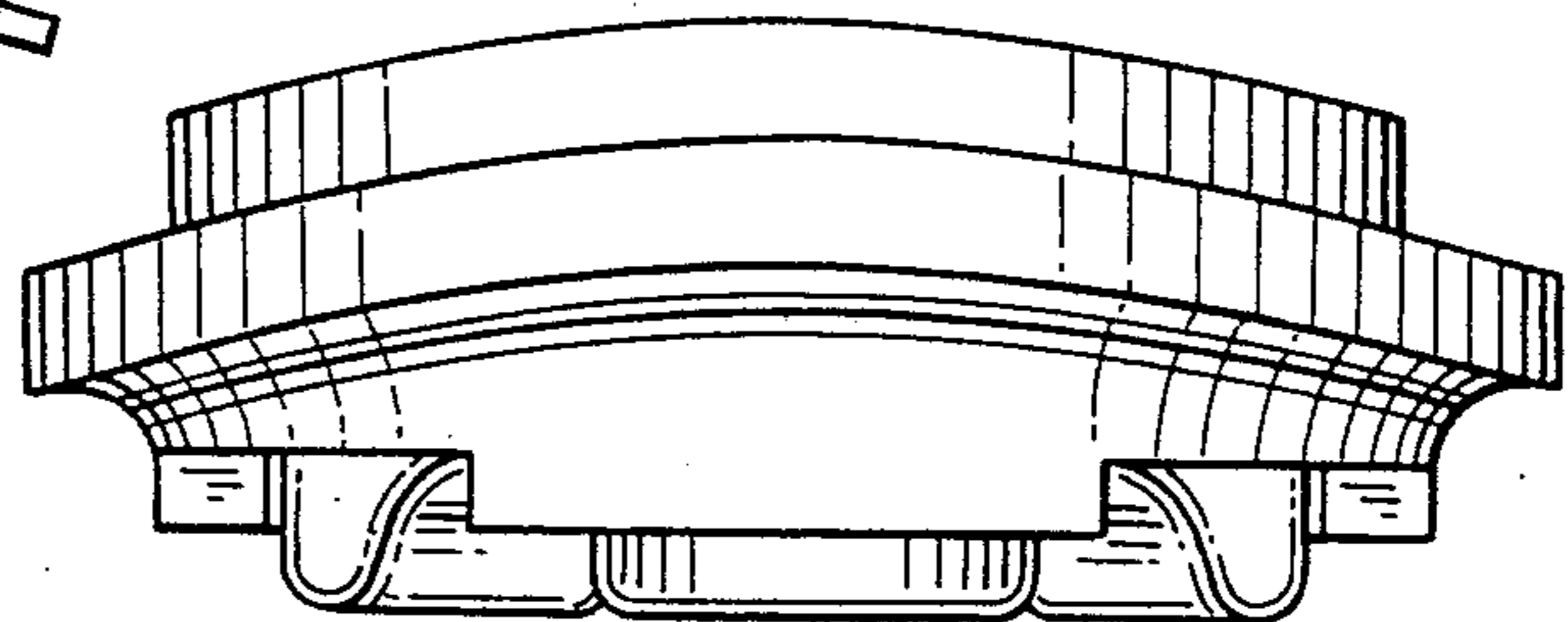

FIG.10

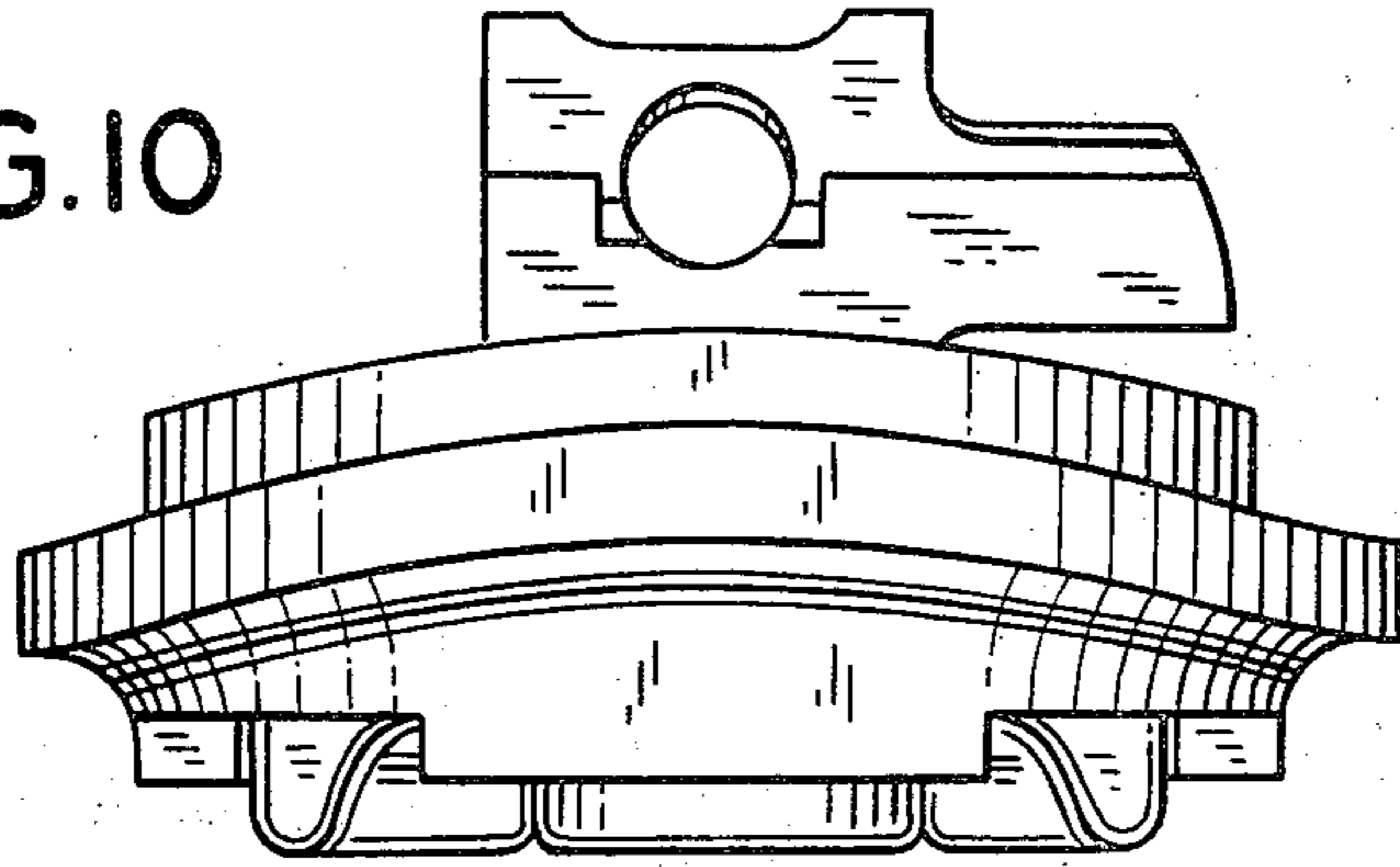

FIG.11

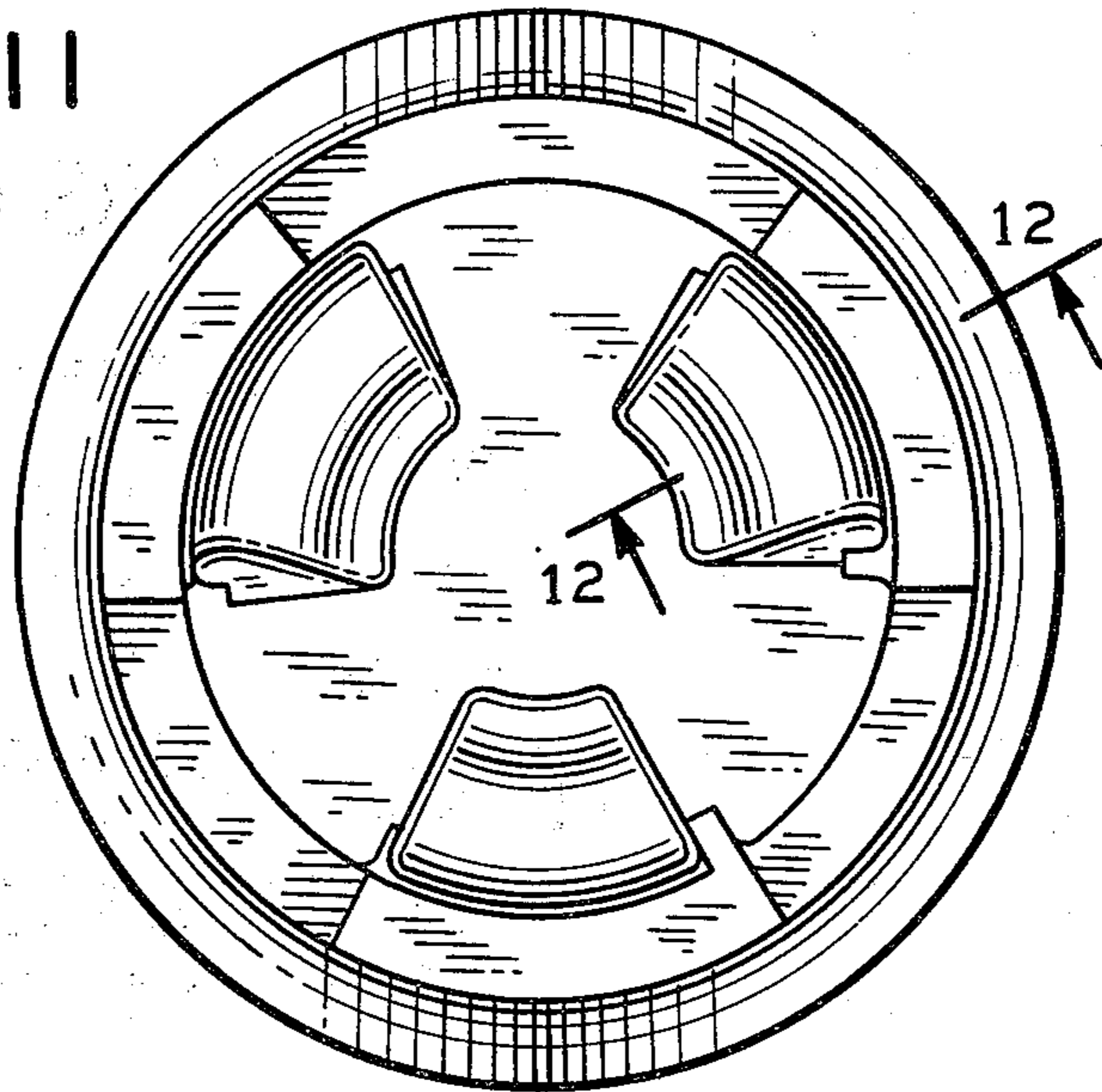

FIG.12

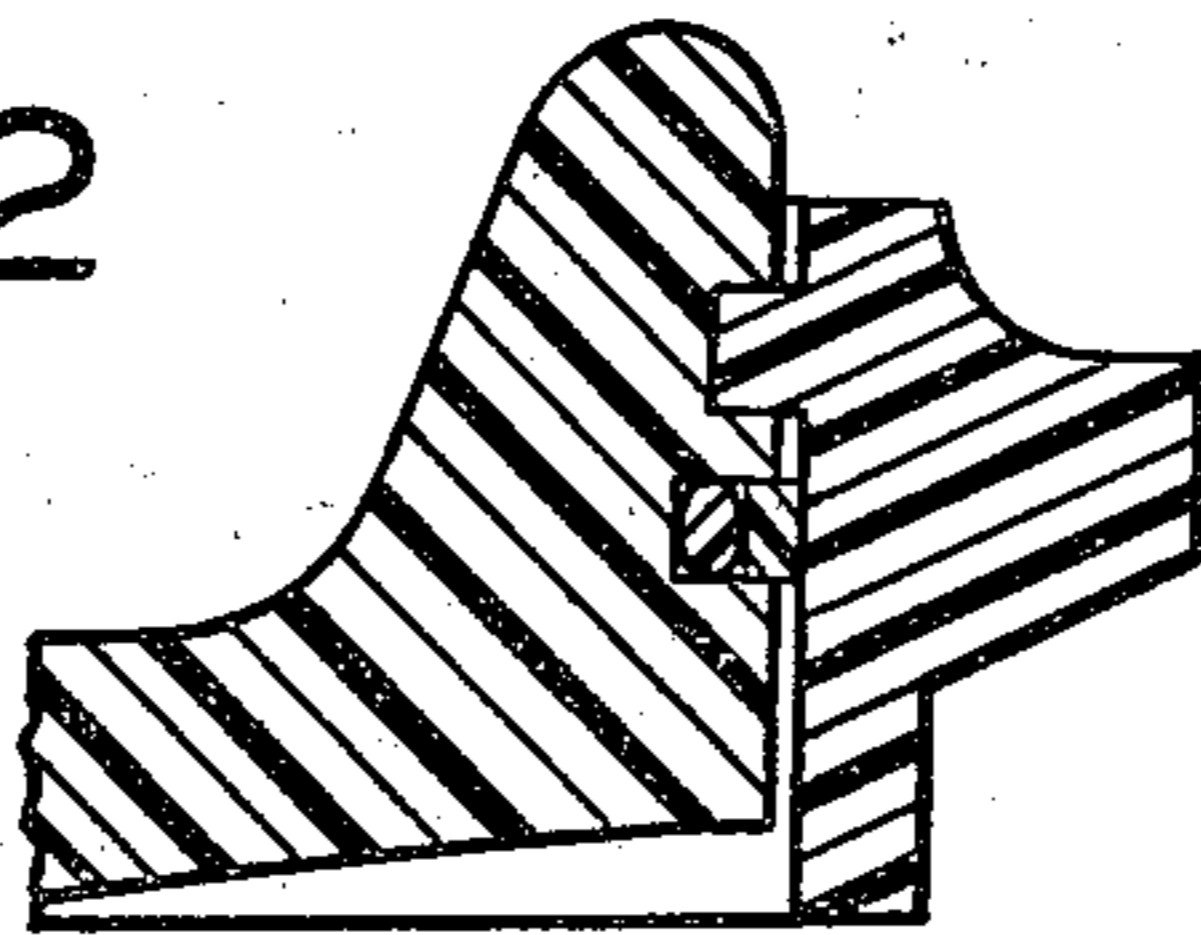

FIG.13

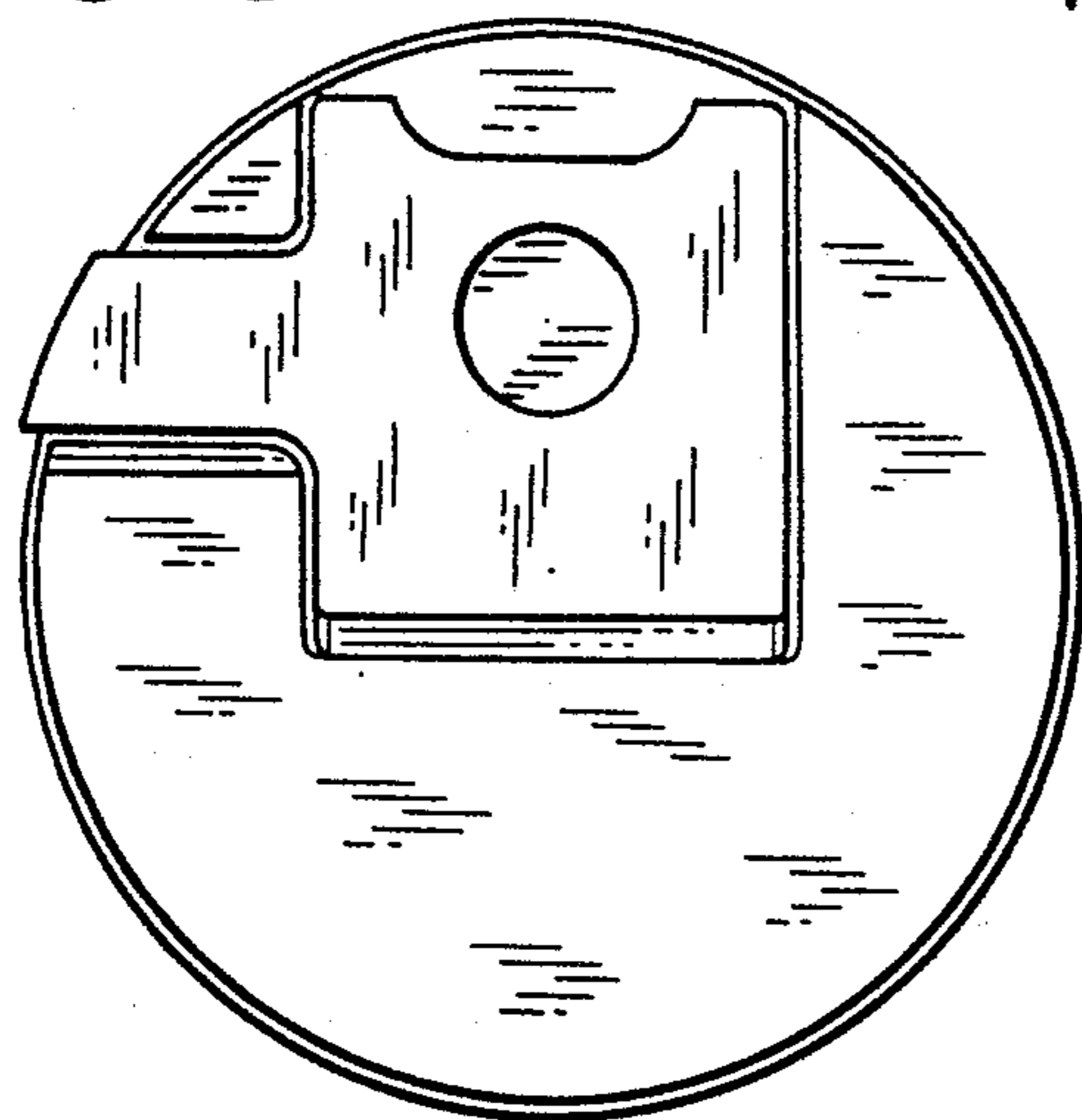

FIG.15

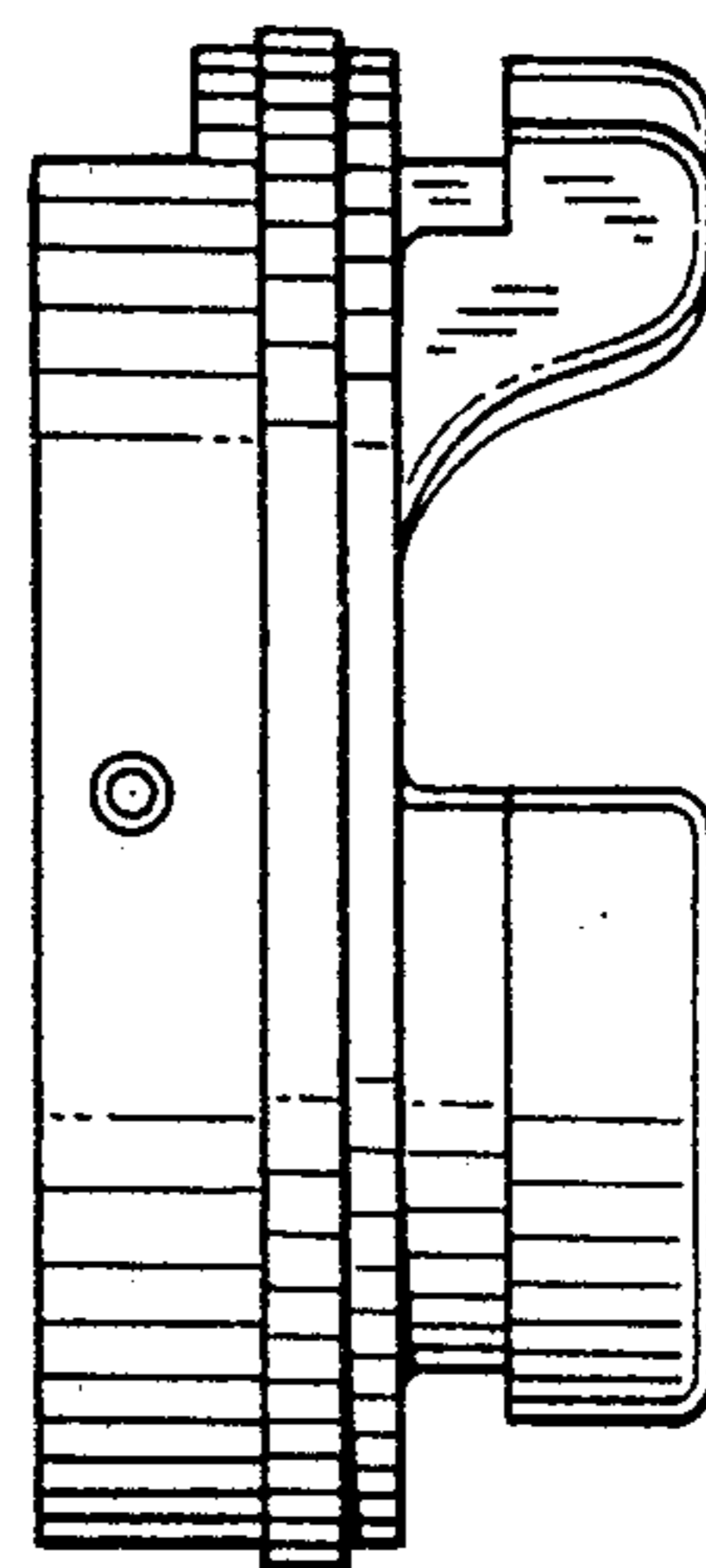

FIG.14

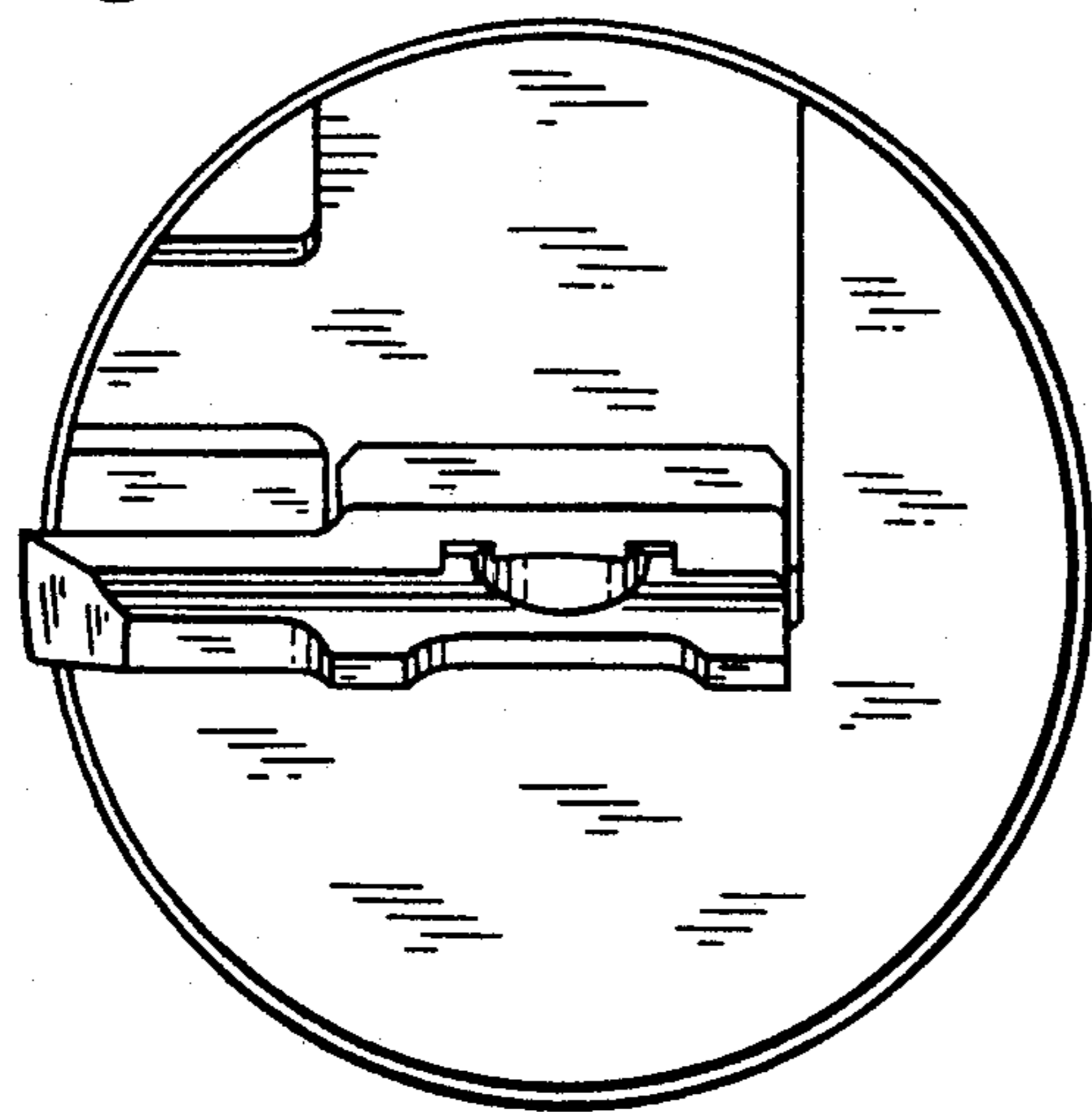

FIG.16

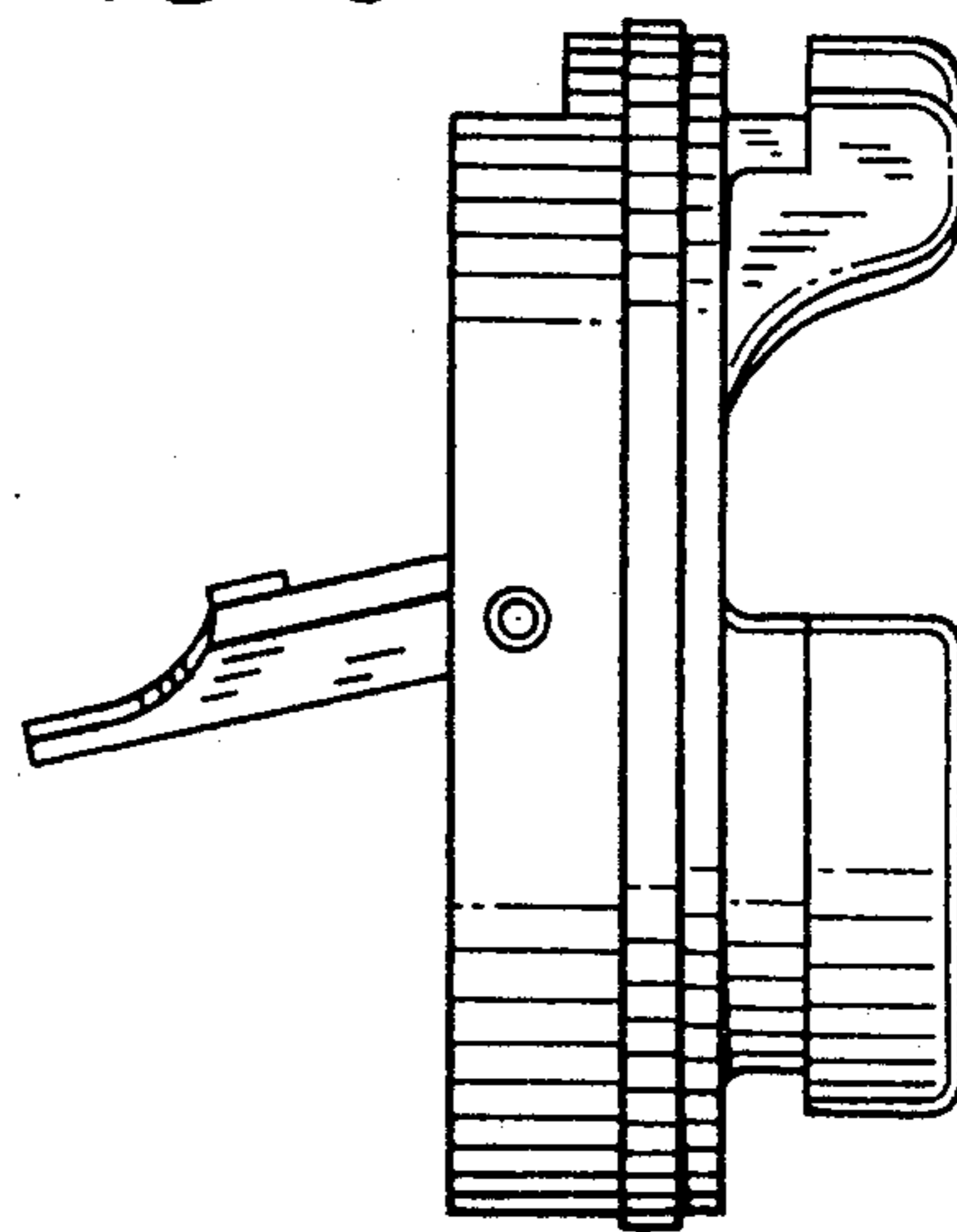
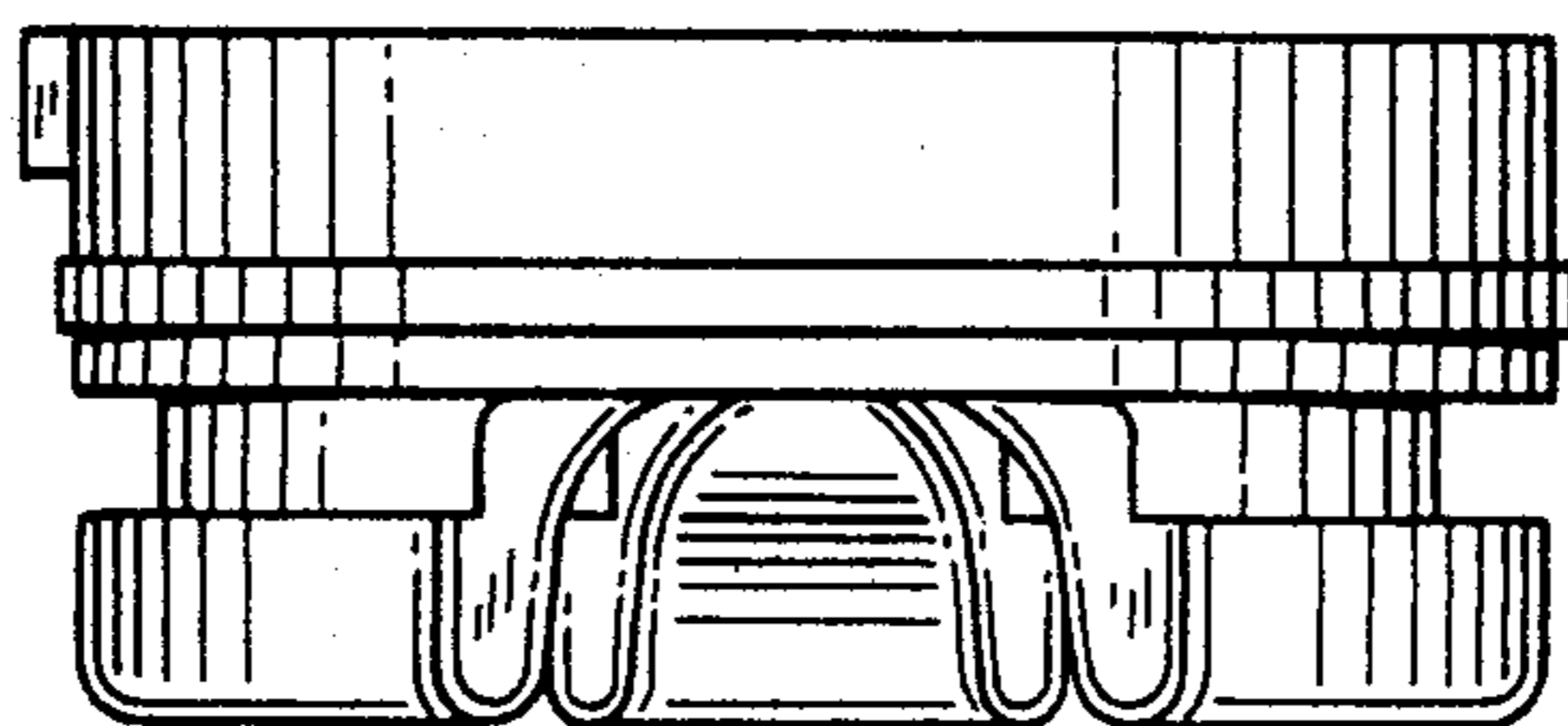

FIG.17



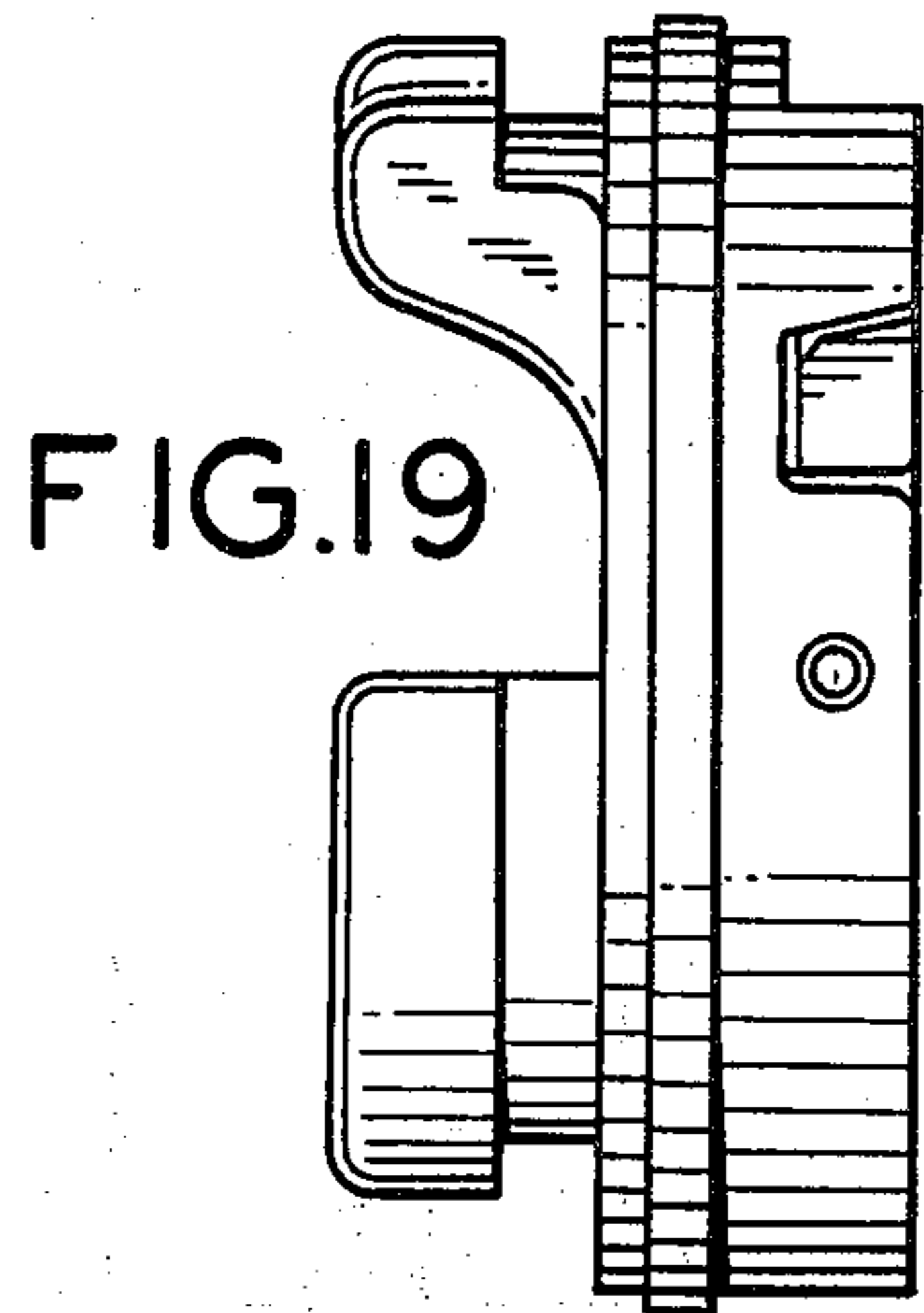

FIG. 19

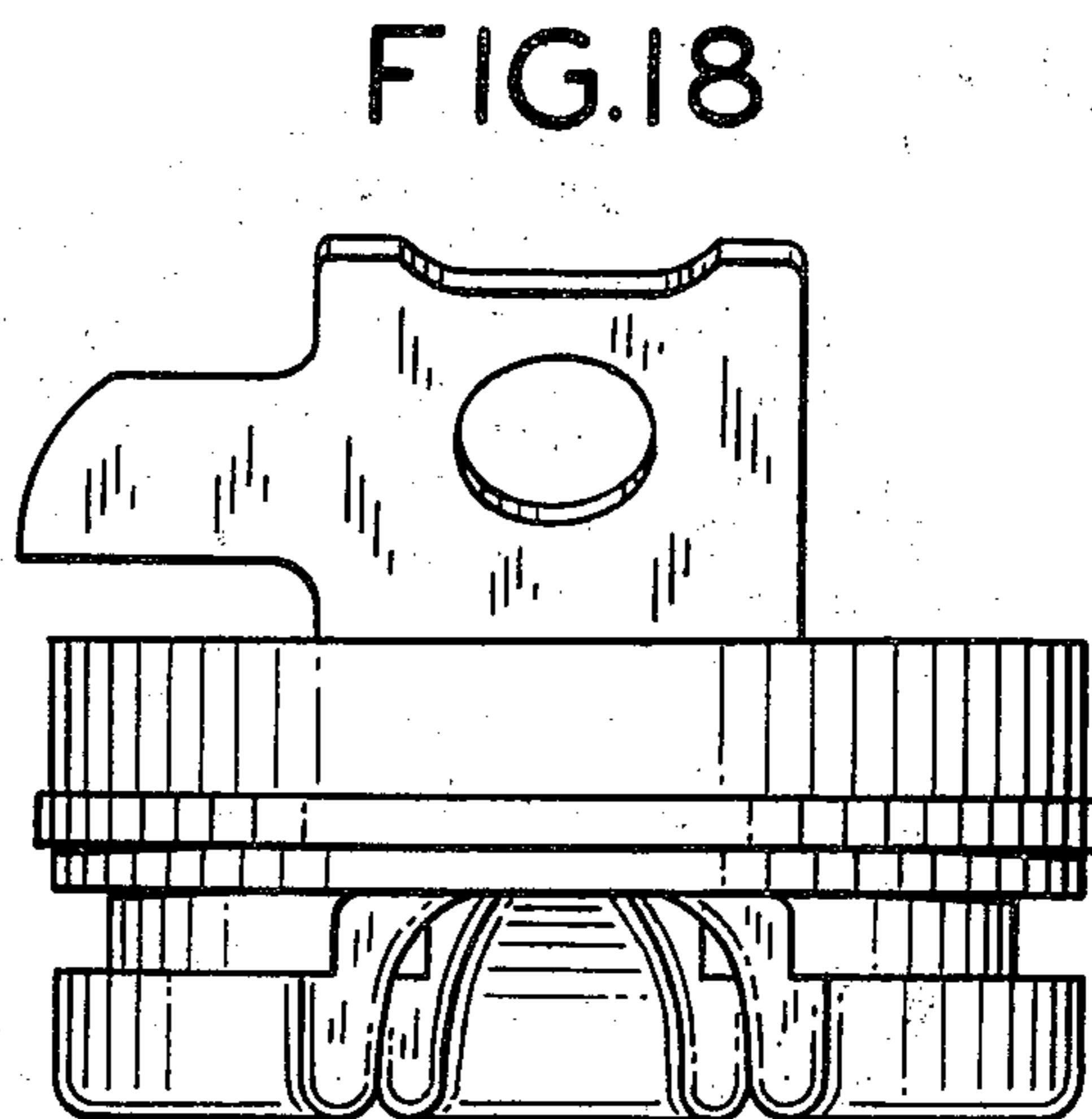

FIG. 18

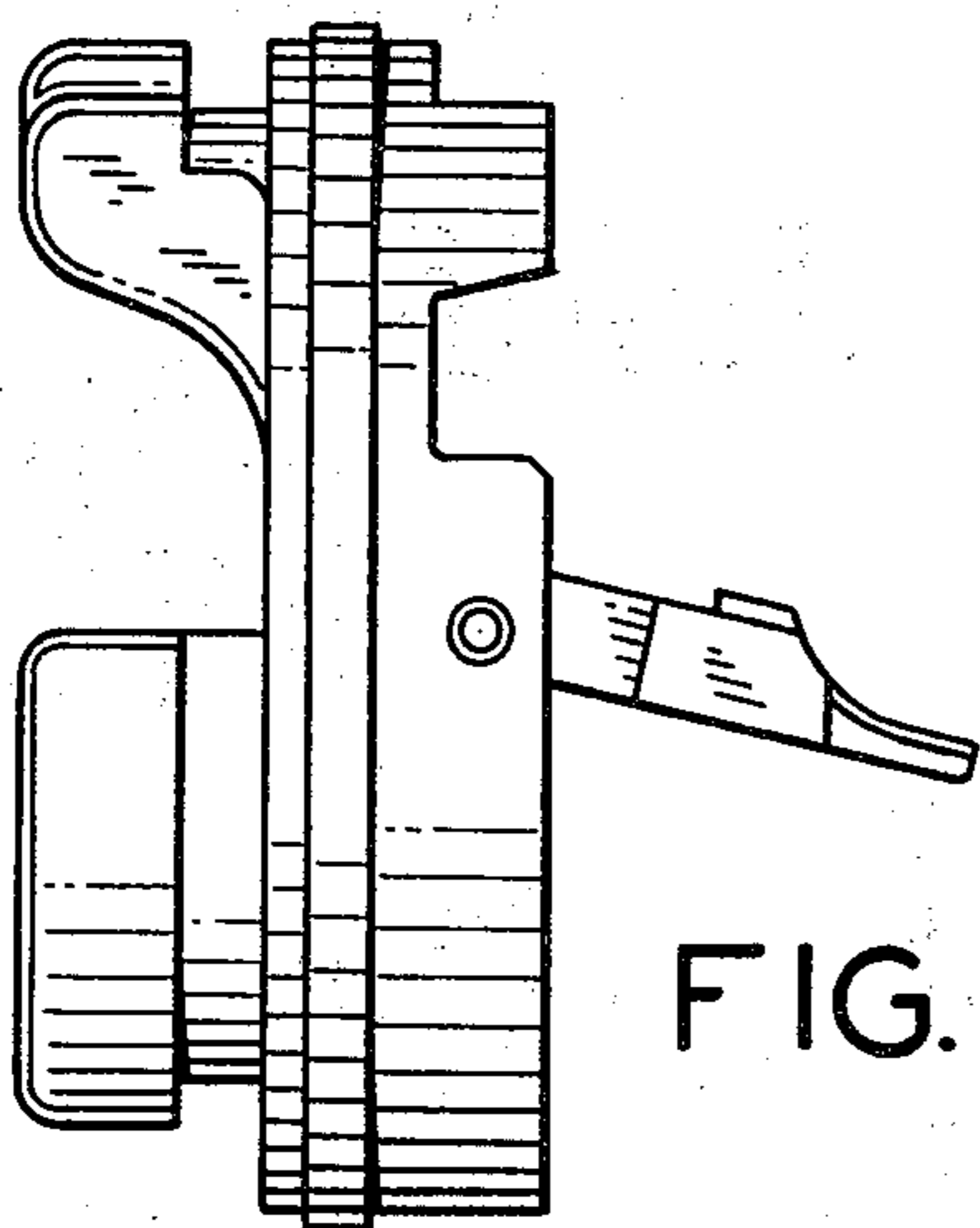

FIG. 20

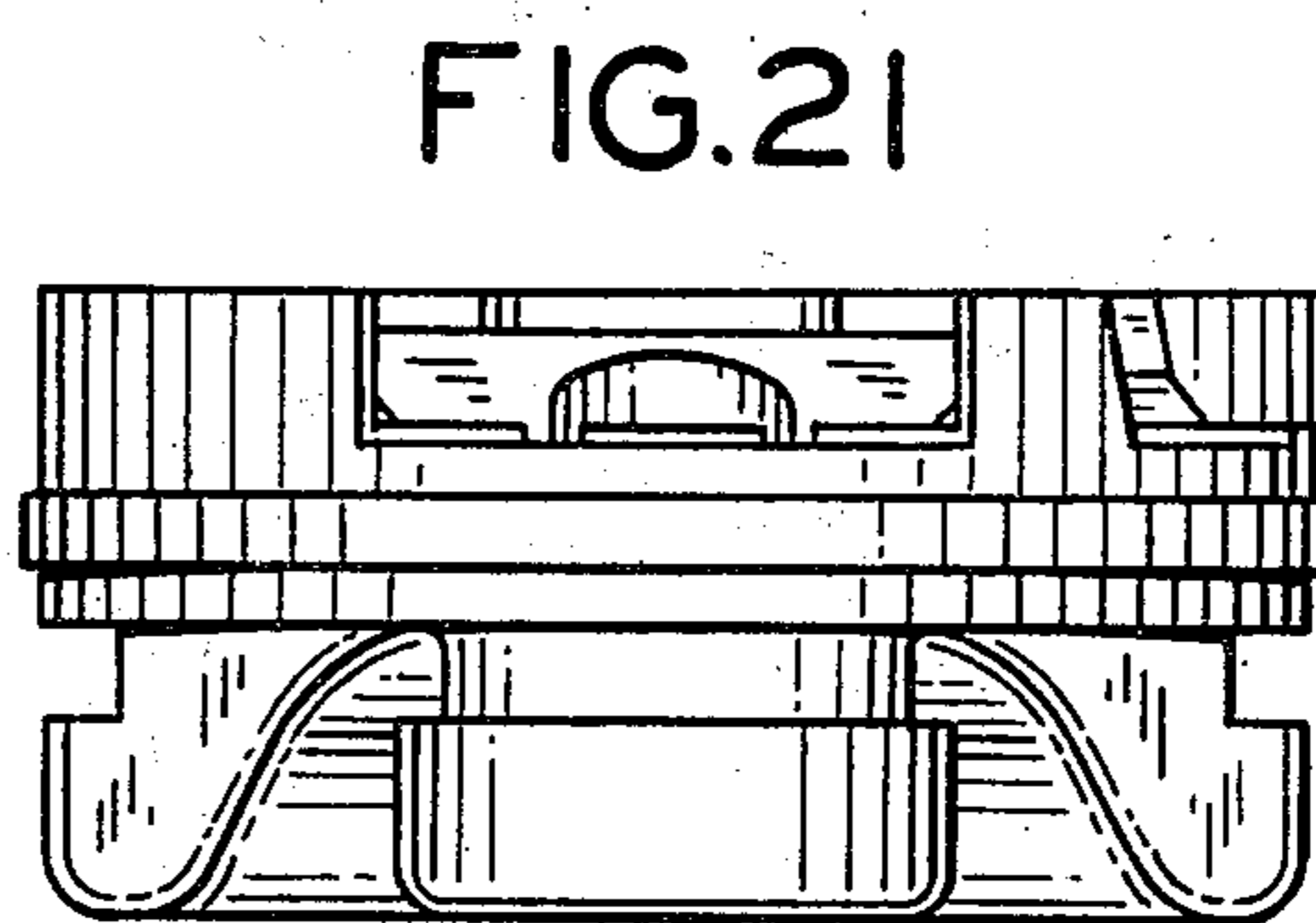

FIG. 21

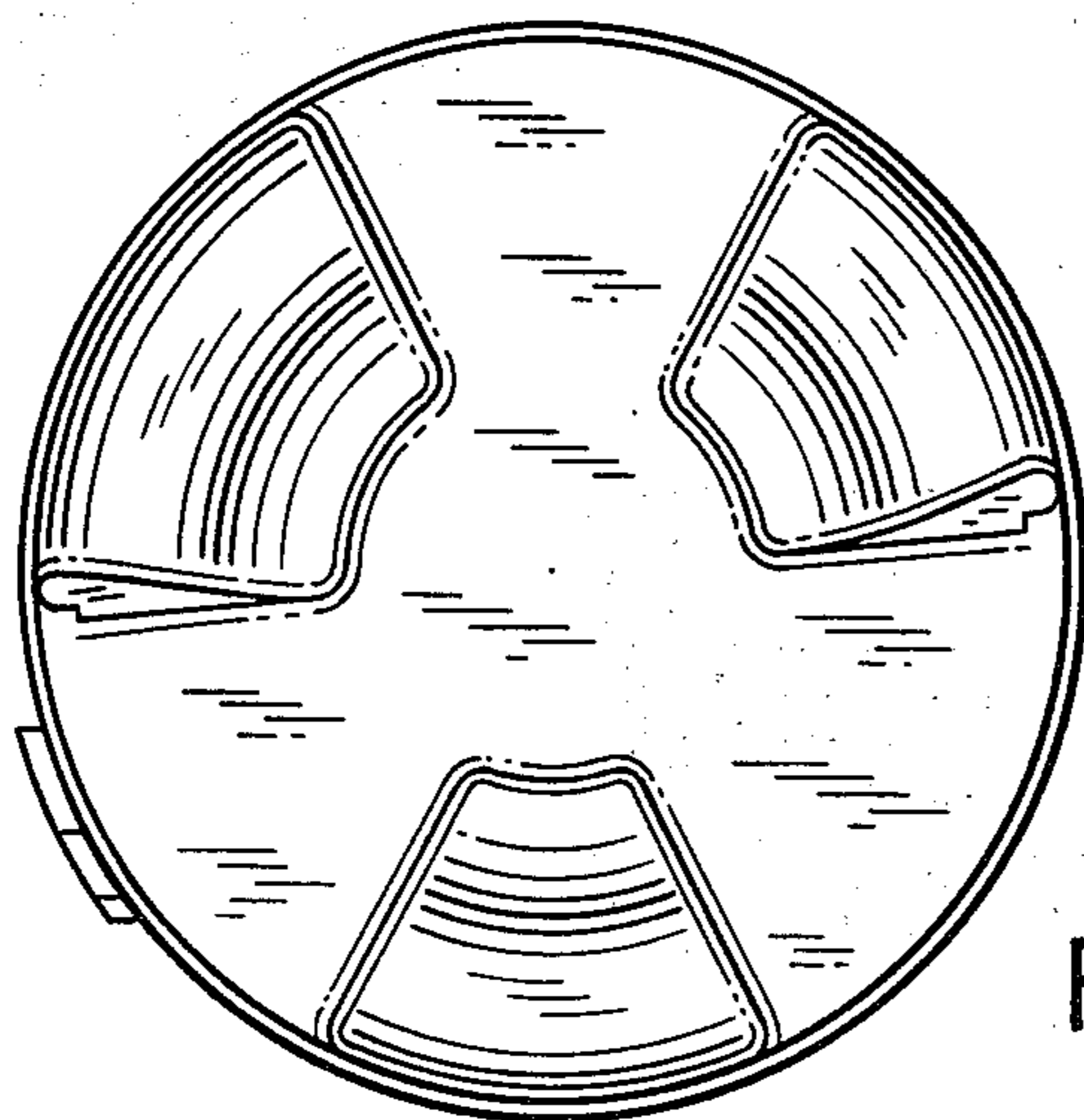

FIG. 23

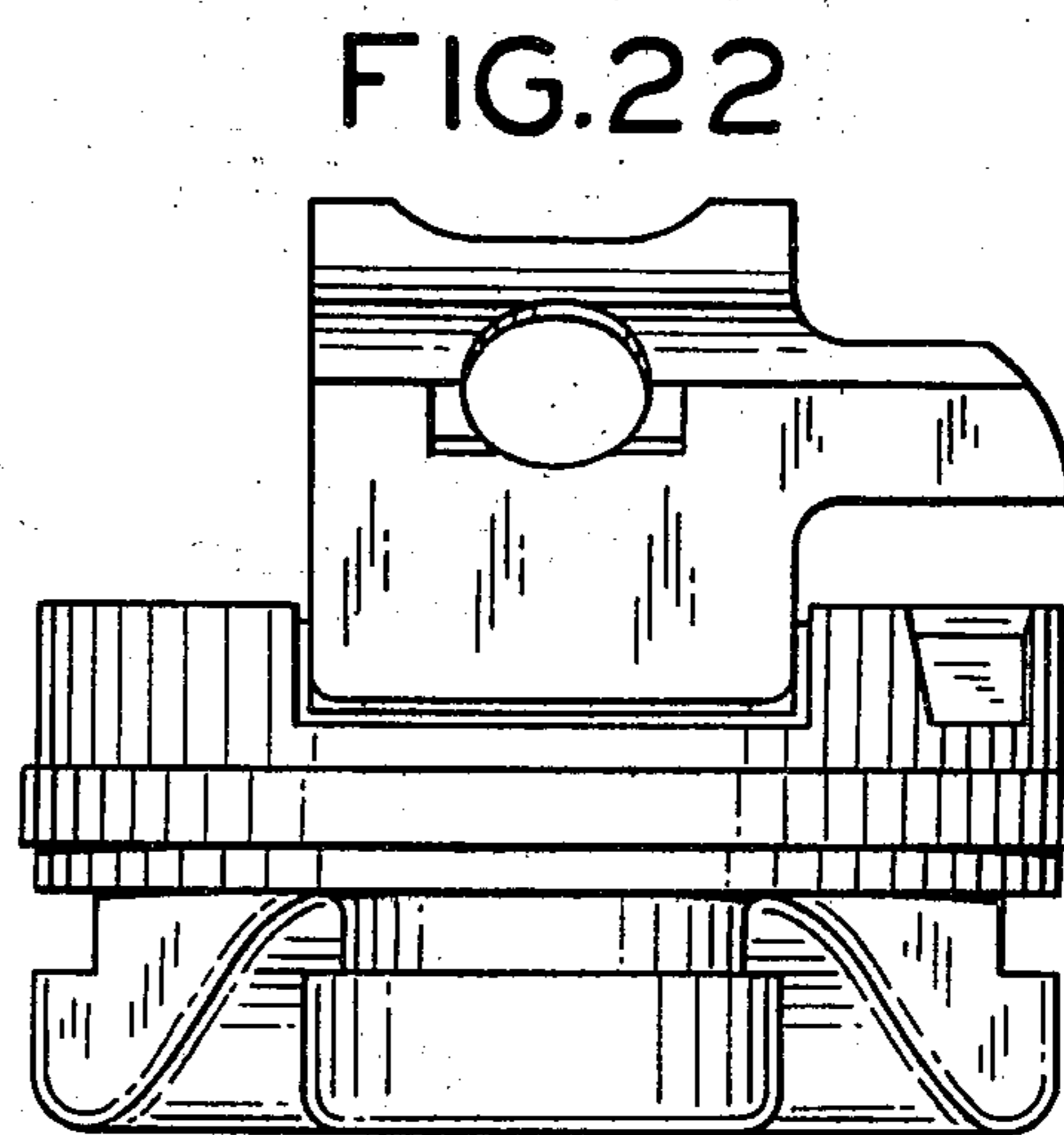

FIG. 22

FIG.24

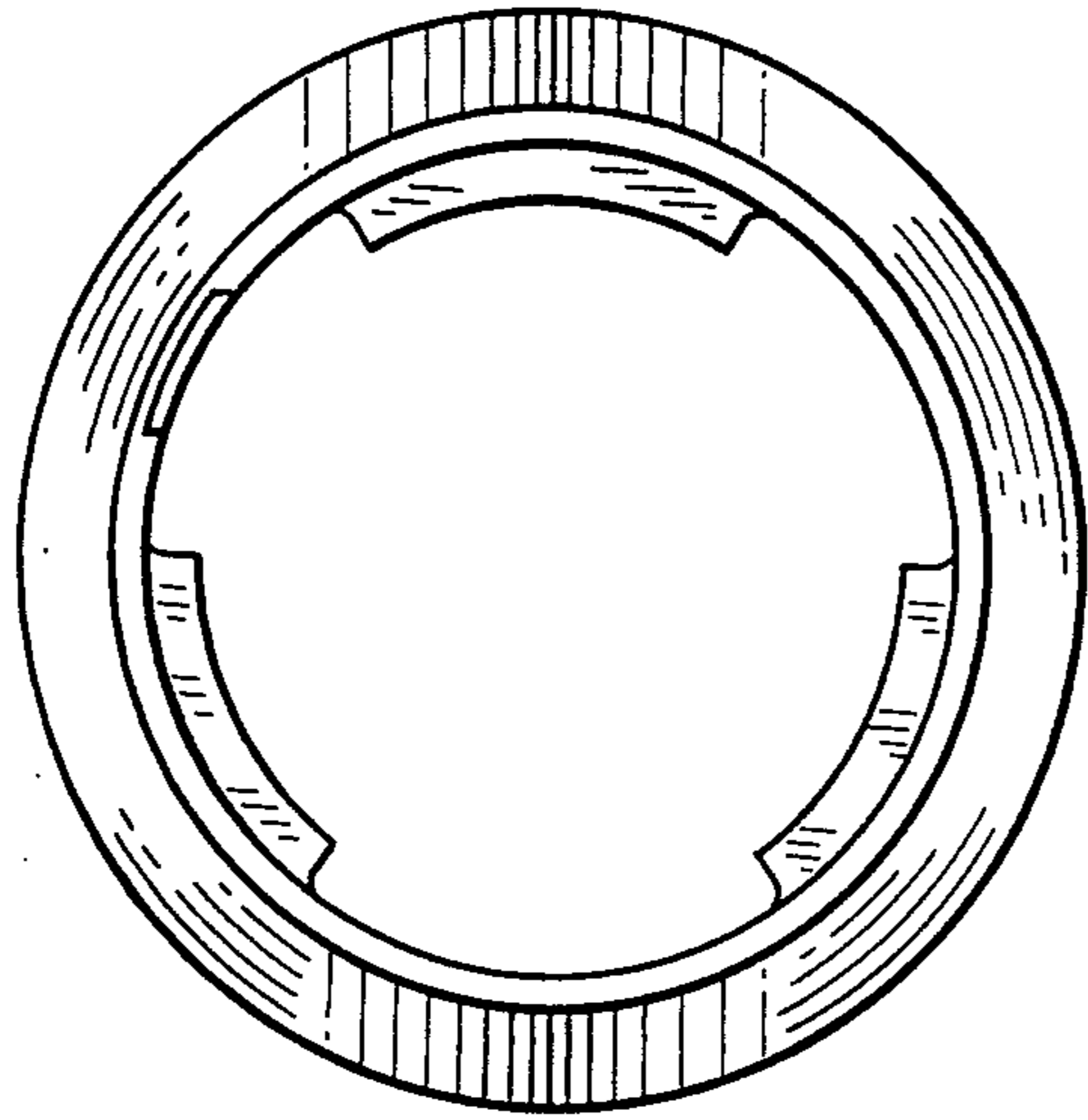

FIG.25

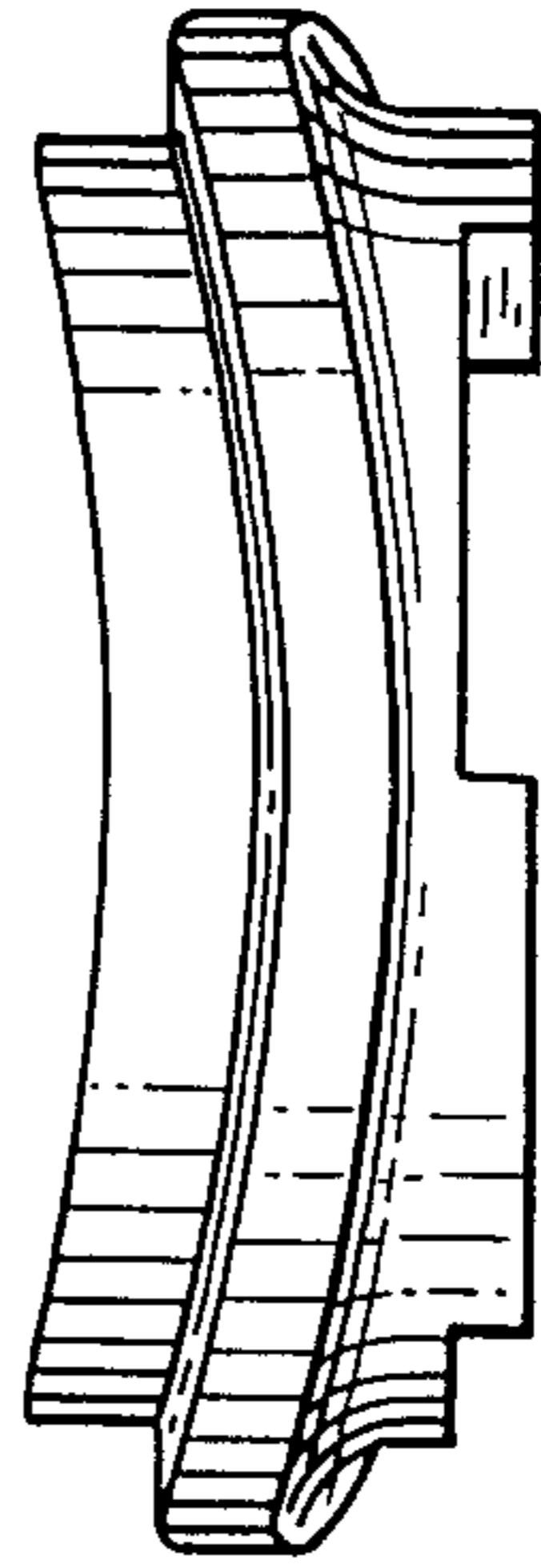

FIG.26

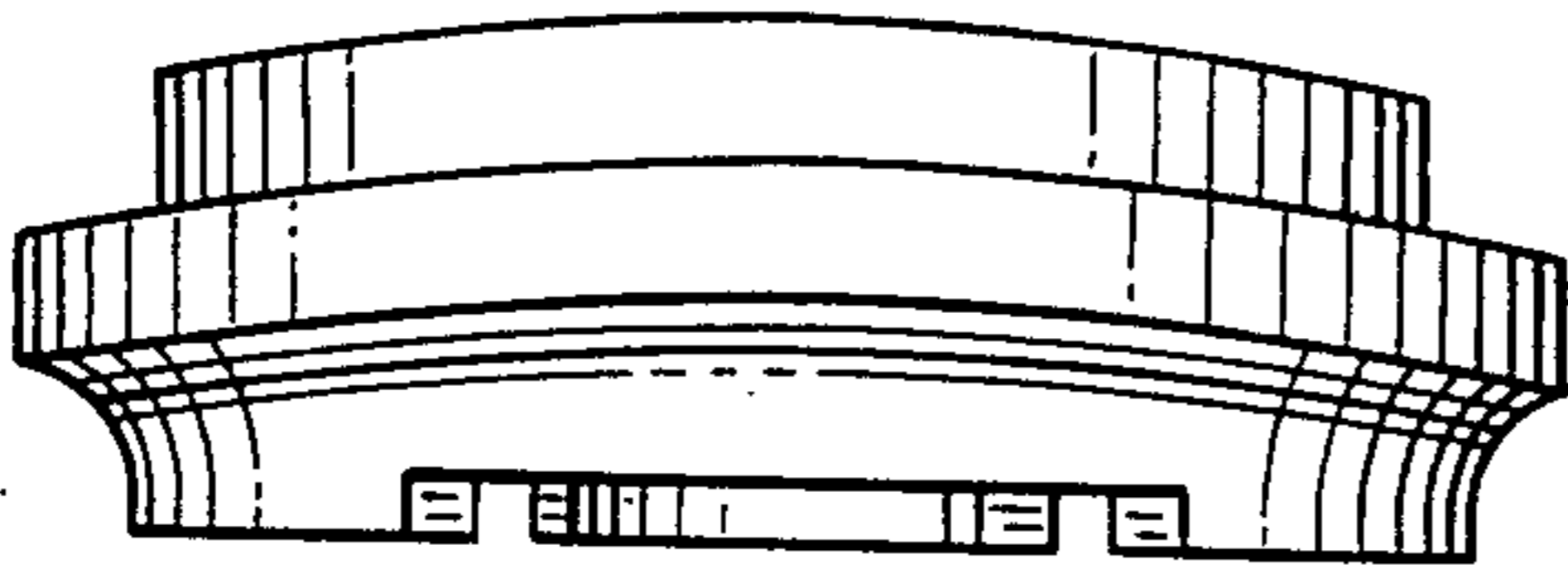

FIG.28

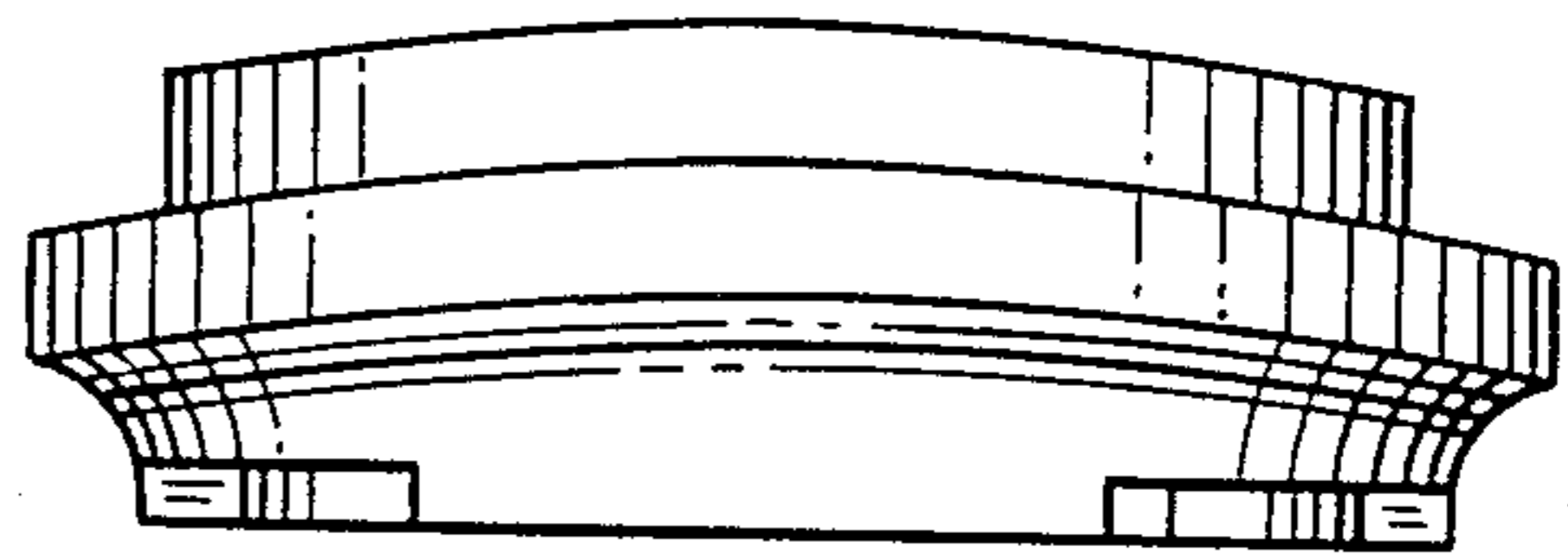

FIG.27

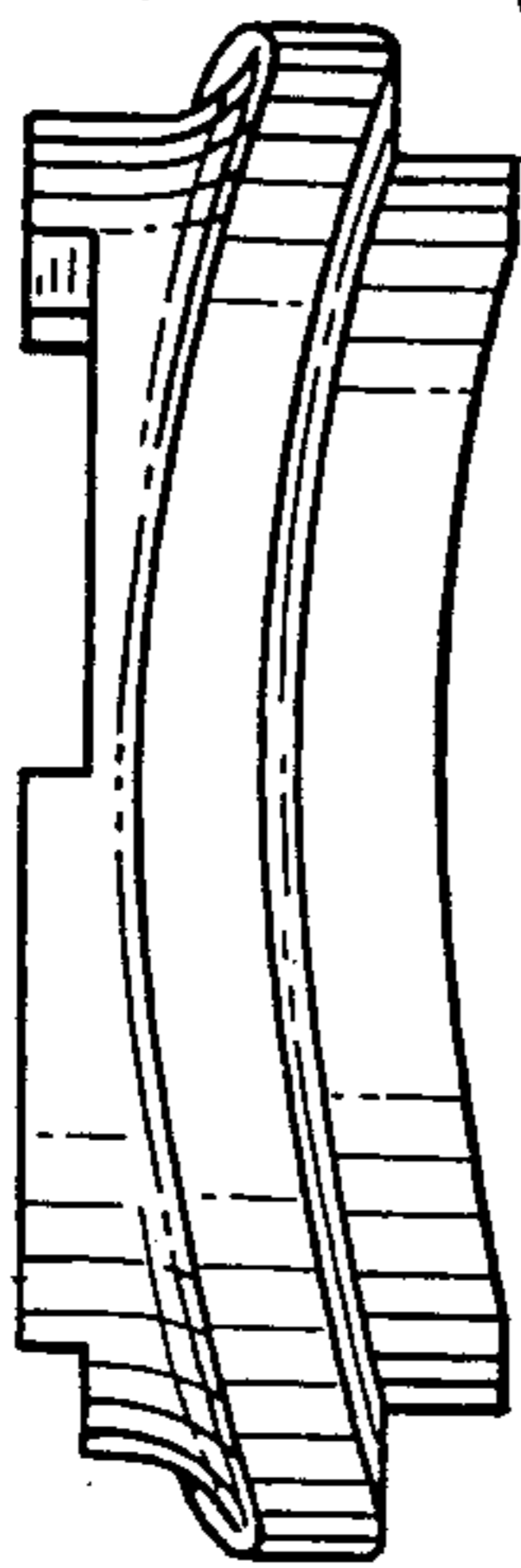

FIG.29

