

[54] TOY AUTOMOBILE

[75] Inventors: Mel Appel, Nine Nottingham Rd., Livingston, N.J. 07039; George Kress, Scotch Plains, N.J.

[73] Assignee: Mel Appel, Livingston, N.J.

[**] Term: 14 Years

[21] Appl. No.: 390,219

[22] Filed: Jun. 21, 1982

[52] U.S. Cl. D21/78

[58] Field of Search D21/73, 76, 78, 79, D21/80, 128, 132, 134, 135, 136, 137, 140; D12/93, 99; 46/201, 210, 222, 223; 280/87.01, 87.04

[56]

References Cited

U.S. PATENT DOCUMENTS

- D. 253,193 10/1979 Pauly D21/136
- D. 259,730 6/1981 Arad et al. D21/78
- 4,361,338 11/1982 Kuchenbecker et al. D21/80

Primary Examiner—Charles A. Rademaker
Attorney, Agent, or Firm—Lerner, David, Littenberg, Krumholz & Mentlik

[57]

CLAIM

The ornamental design for a toy automobile, substantially as shown and described.

DESCRIPTION

FIG. 1 is a perspective view of a toy automobile showing our new design;
 FIG. 2 is a left side elevational view thereof, the right side elevational view being a mirror image thereto;
 FIG. 3 is a front elevational view thereof;
 FIG. 4 is a rear elevational view thereof;
 FIG. 5 is a top plan view thereof; and
 FIG. 6 is a bottom plan view thereof.

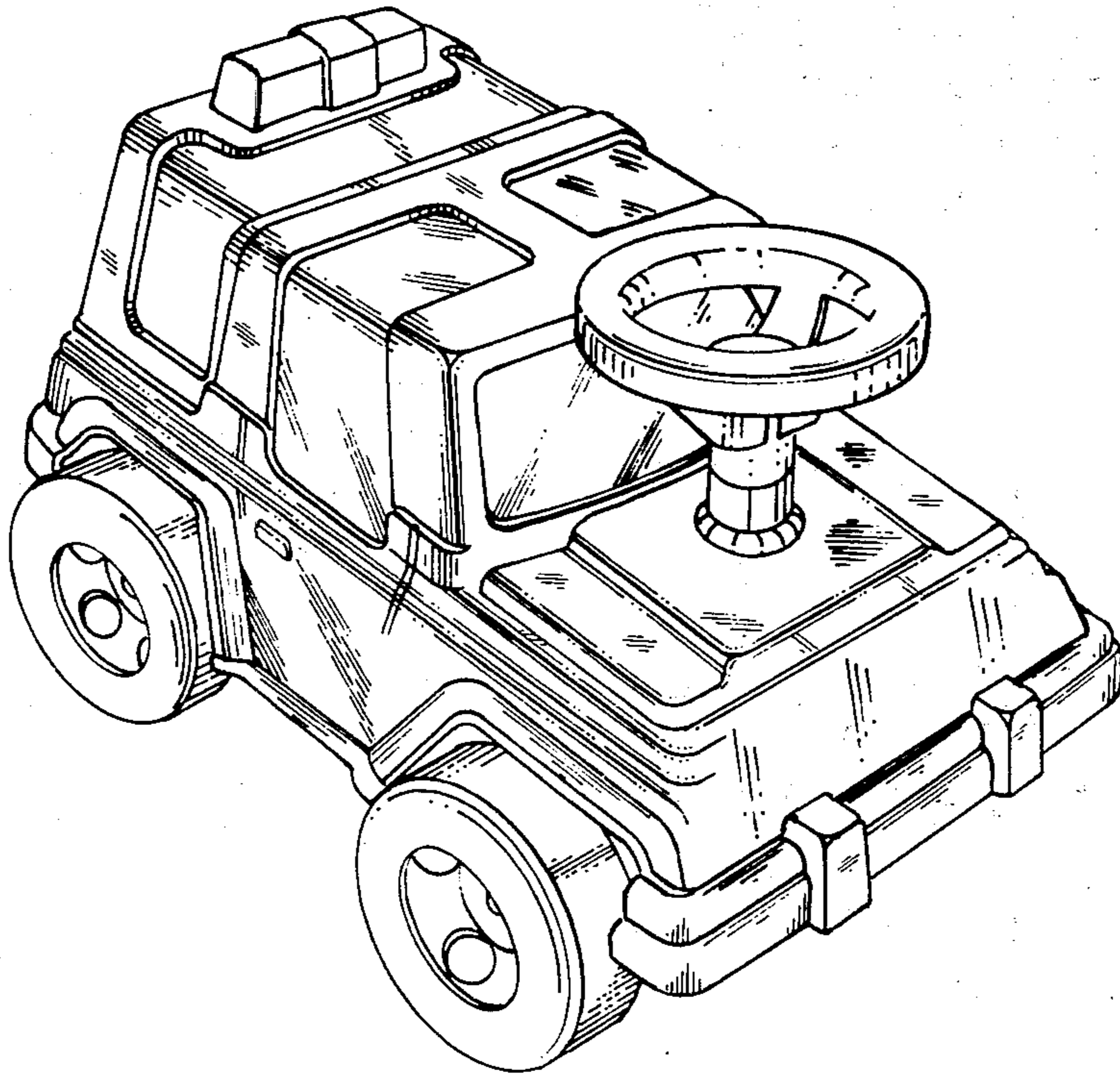

FIG. 1

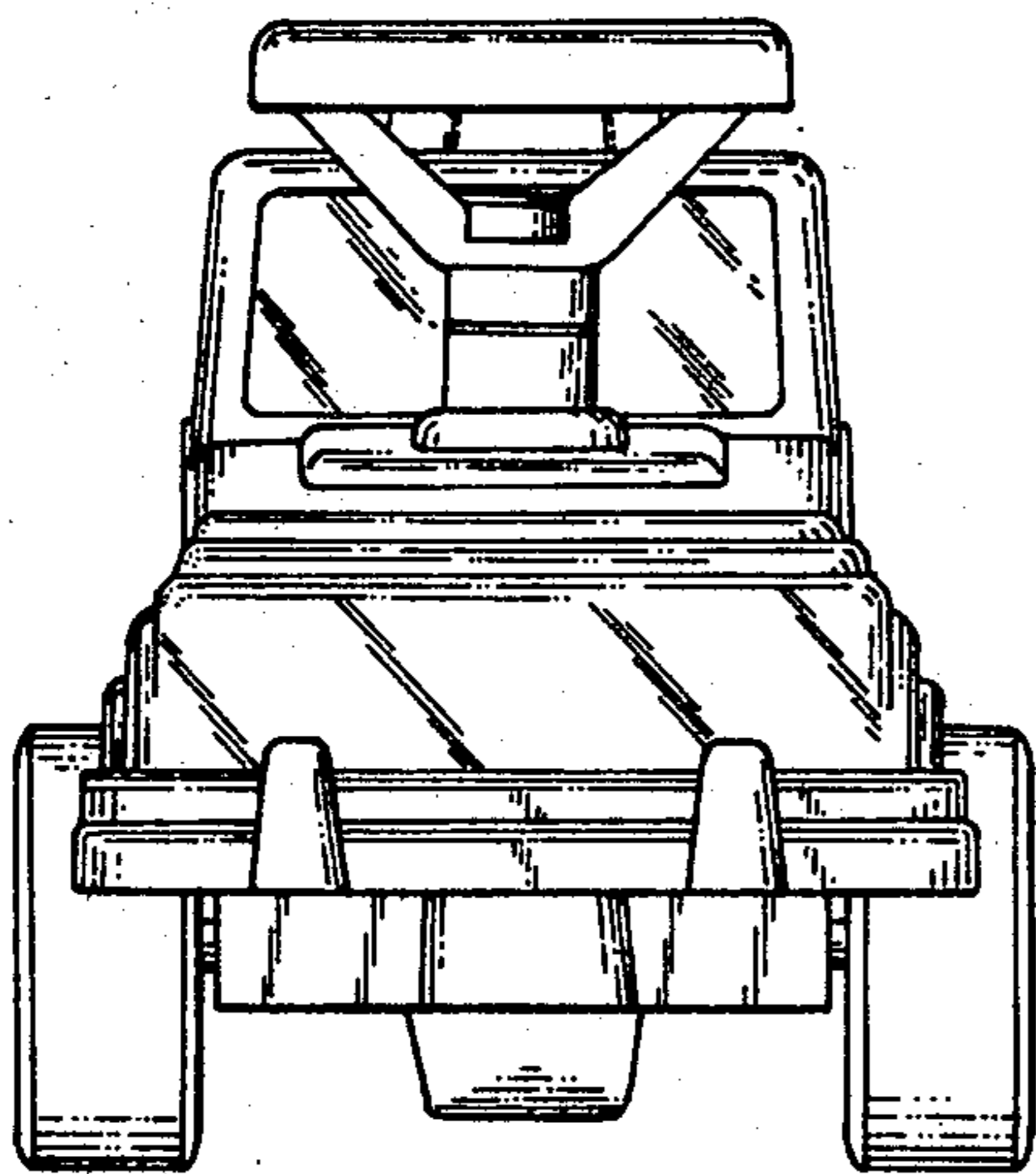
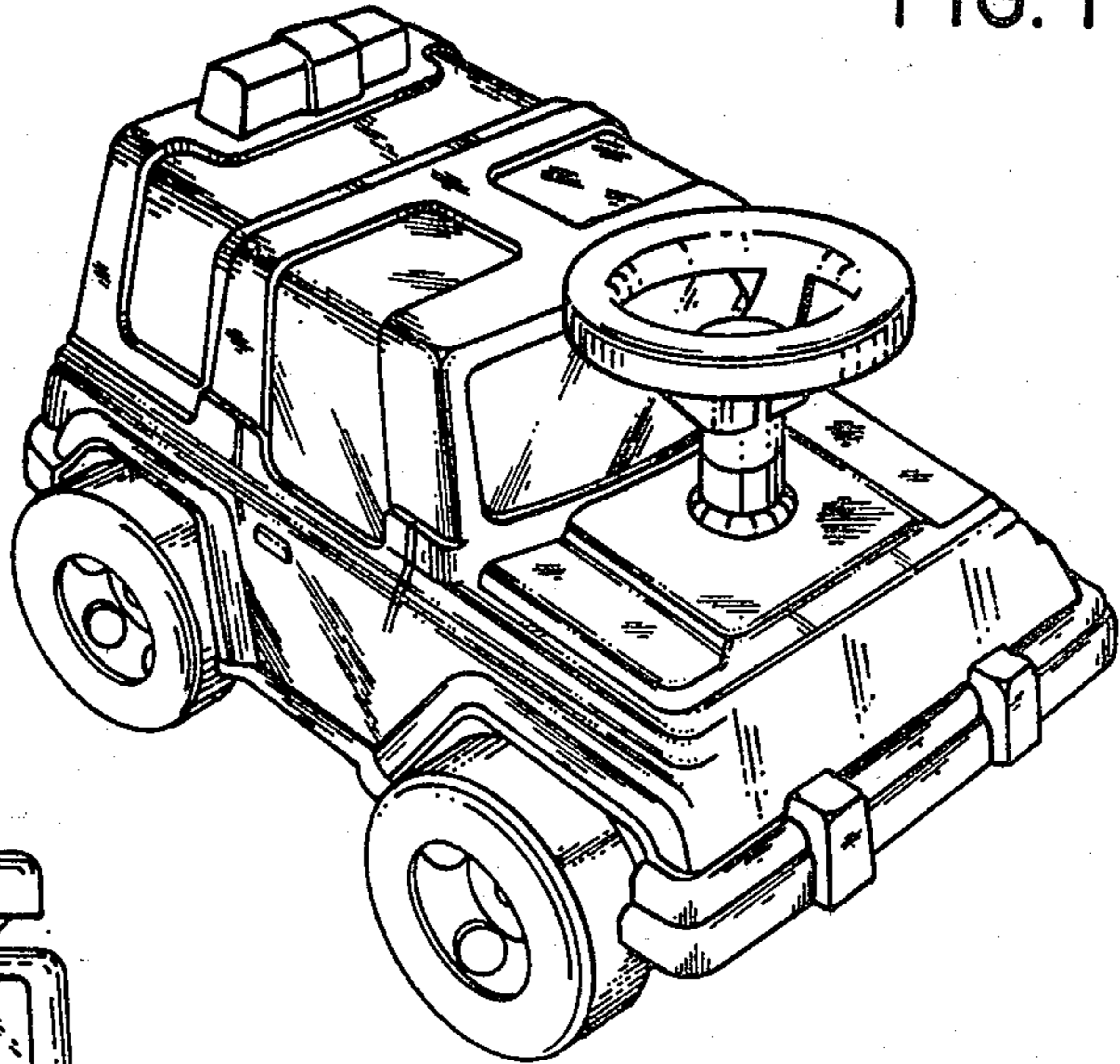

FIG. 3

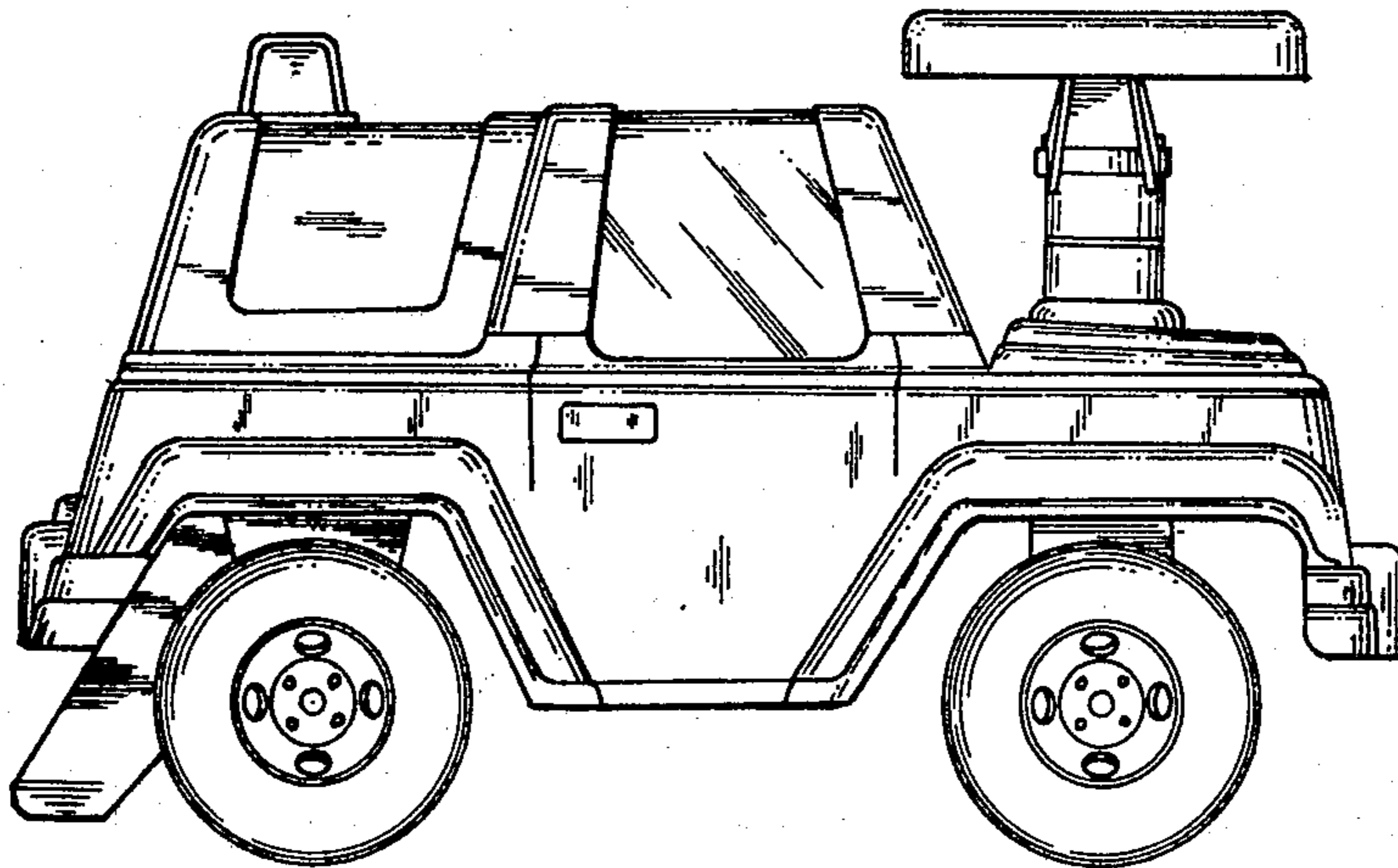

FIG. 2

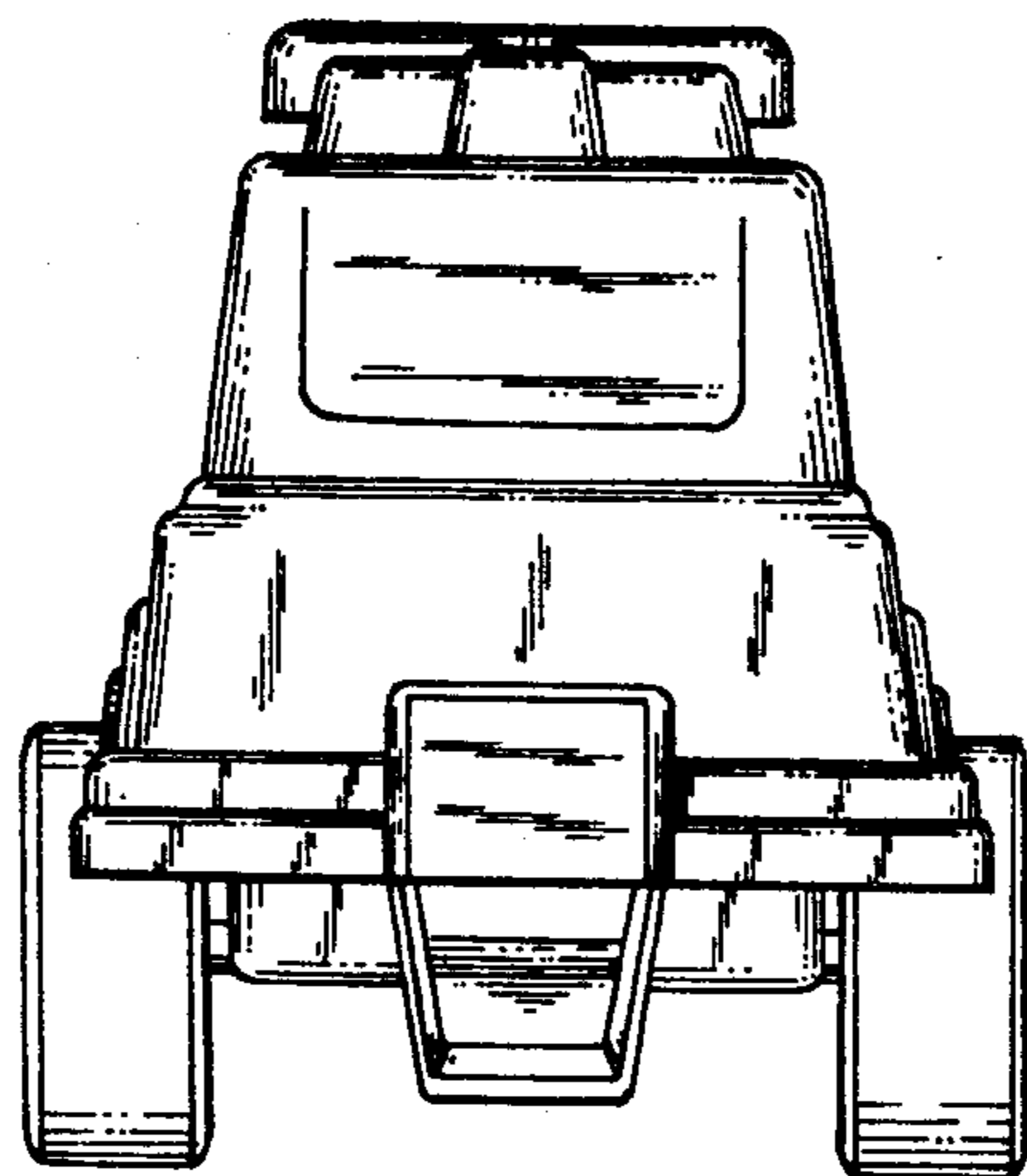

FIG. 4

FIG. 5

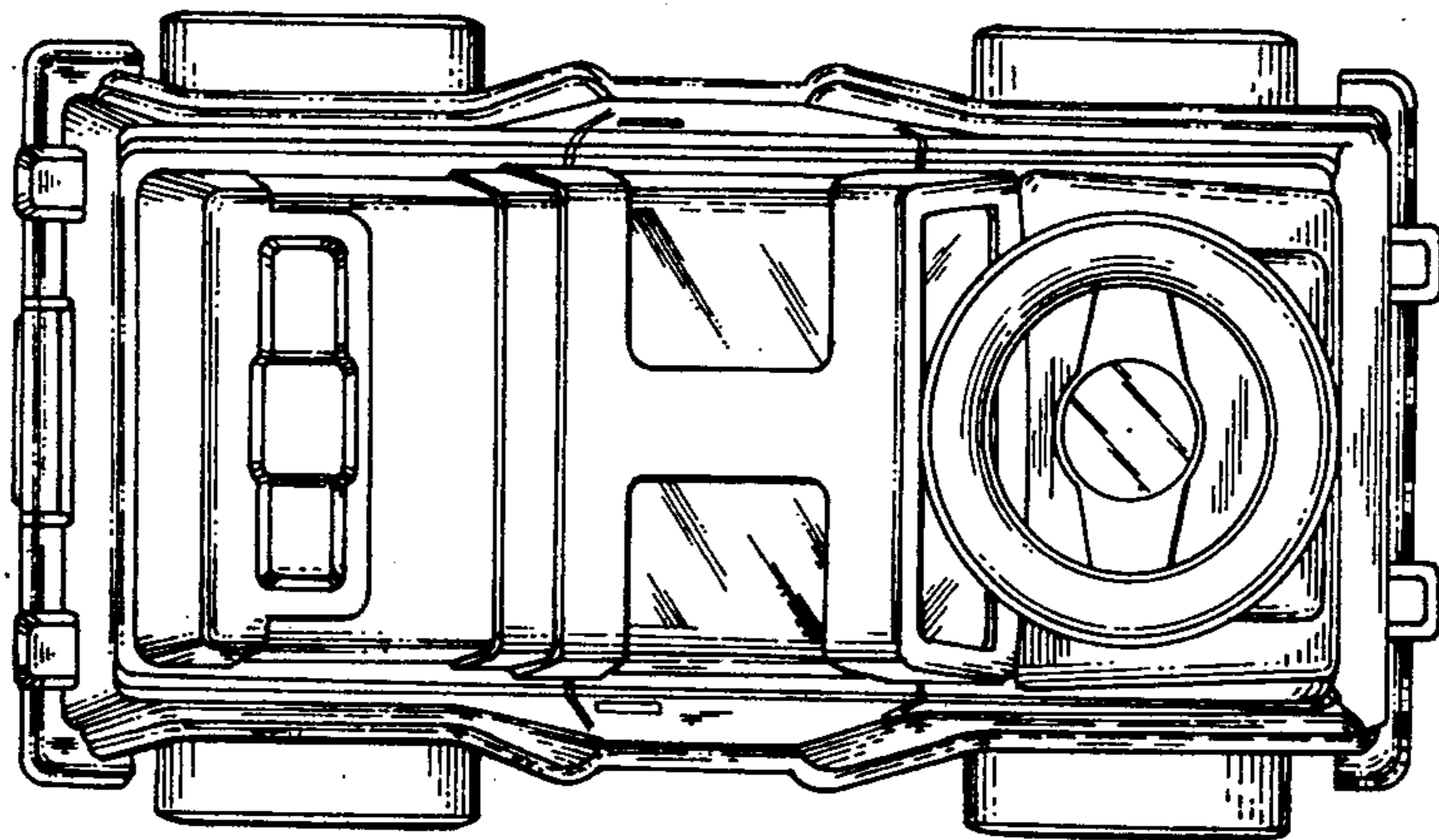

FIG. 6

