

[54] CARRIER FOR A BICYCLE

4,053,091 10/1977 Martelet 224/32 A
4,085,968 4/1978 Svensson et al. 297/243

[76] Inventor: John P. Kusz, 5536 N. Monitor,
Chicago, Ill. 60630

Primary Examiner—James M. Gandy

[**] Term: 14 Years

[57] CLAIM

[21] Appl. No.: 225,707

The ornamental design for a carrier for a bicycle, substantially as shown and described.

[22] Filed: Jan. 16, 1981

[52] U.S. Cl. D12/158

DESCRIPTION

[58] Field of Search D12/158, 114; D6/48.1;
224/32 A; 280/202, 289 A; 297/243

FIG. 1 is a top front perspective view of a carrier for a bicycle showing my new design, it being understood that the broken lines are for illustrative purposes only; FIG. 2 is a front perspective view thereof; FIG. 3 is a rear perspective view thereof; FIG. 4 is an enlarged rear elevational view thereof; FIG. 5 is an enlarged bottom plan view thereof; and FIG. 6 is a cross sectional view thereof taken along line 6—6 in FIG. 4.

[56] References Cited

U.S. PATENT DOCUMENTS

- D. 224,074 6/1972 Harmon, Jr. D12/158
- D. 237,168 10/1975 Scott et al. D12/158
- D. 240,298 6/1976 Kline D12/158
- 4,026,448 5/1977 Lewis 224/32 A

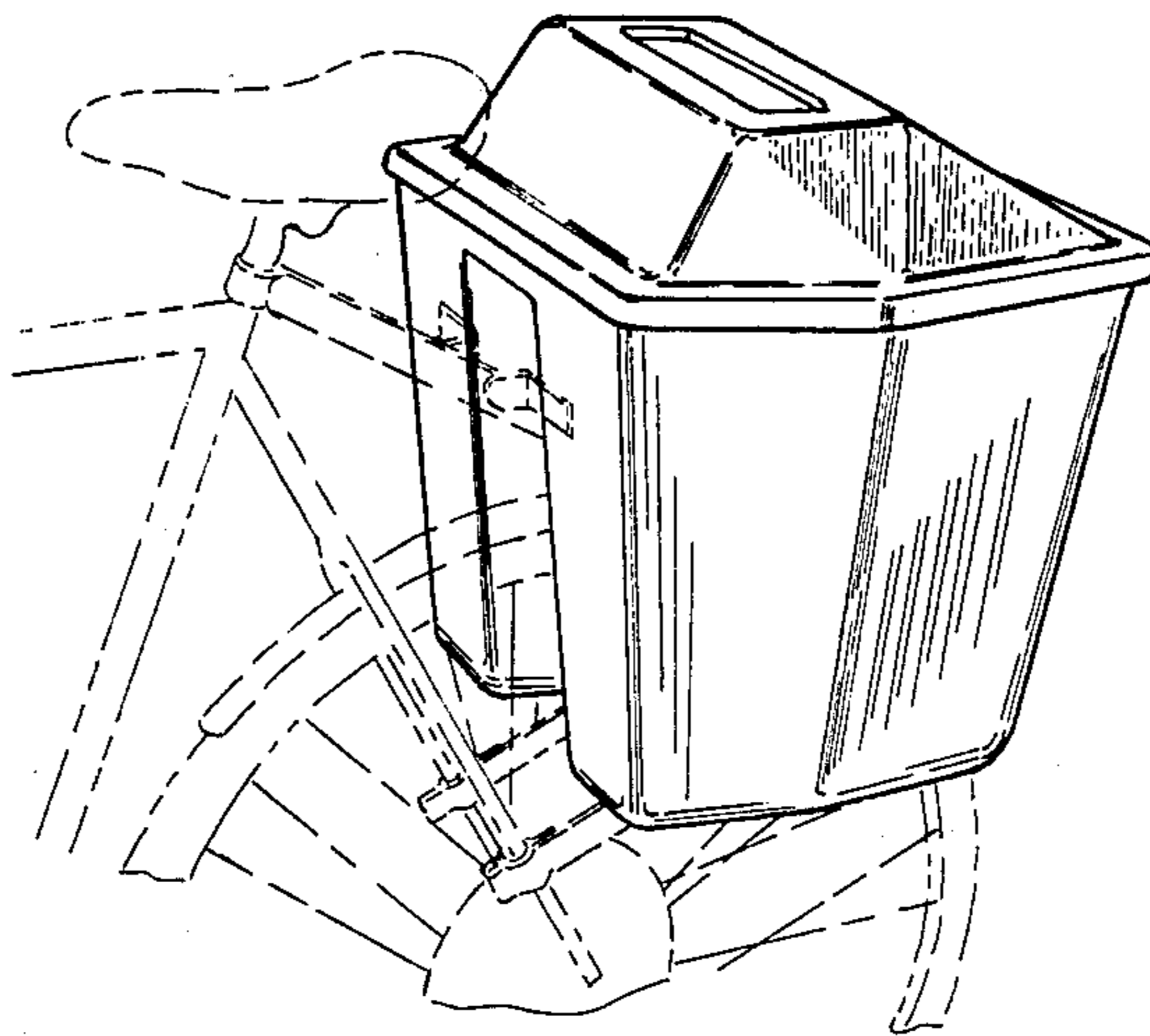

FIG. 1.

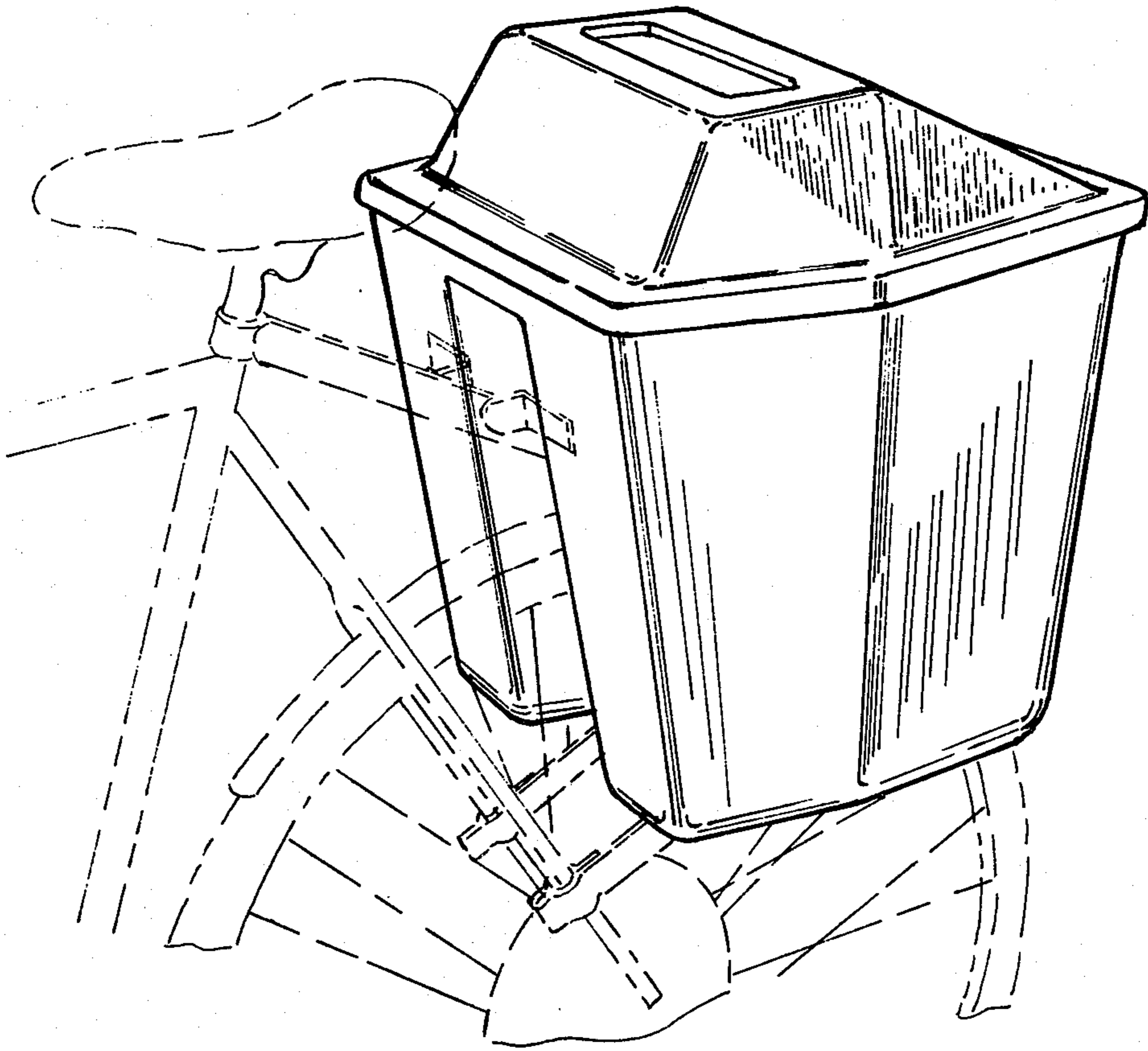

FIG. 3.

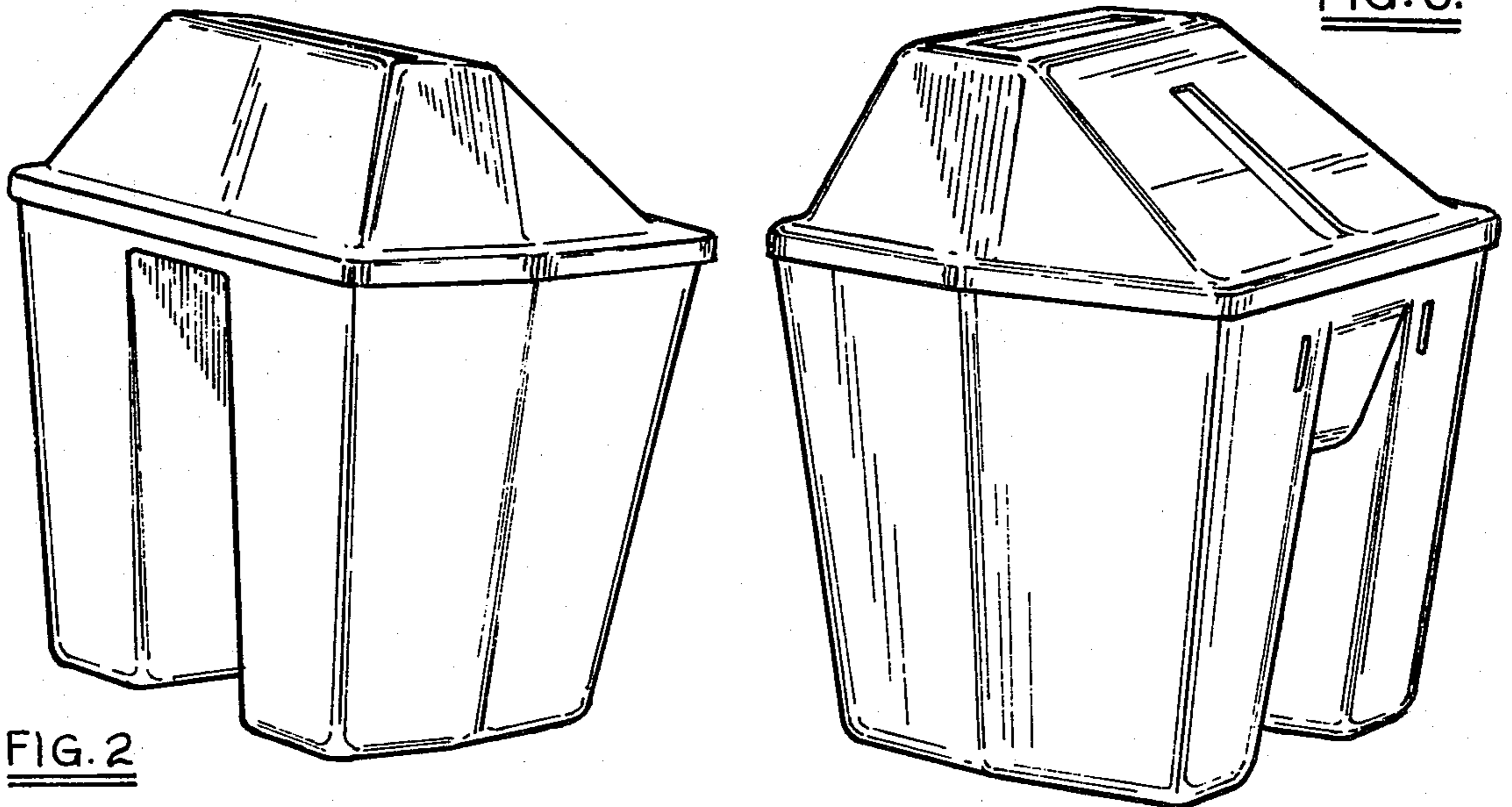

FIG. 2

FIG. 4.

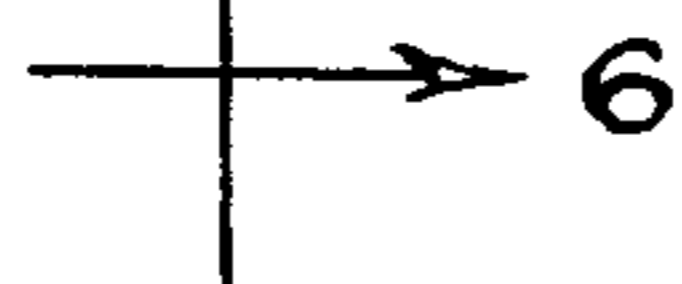
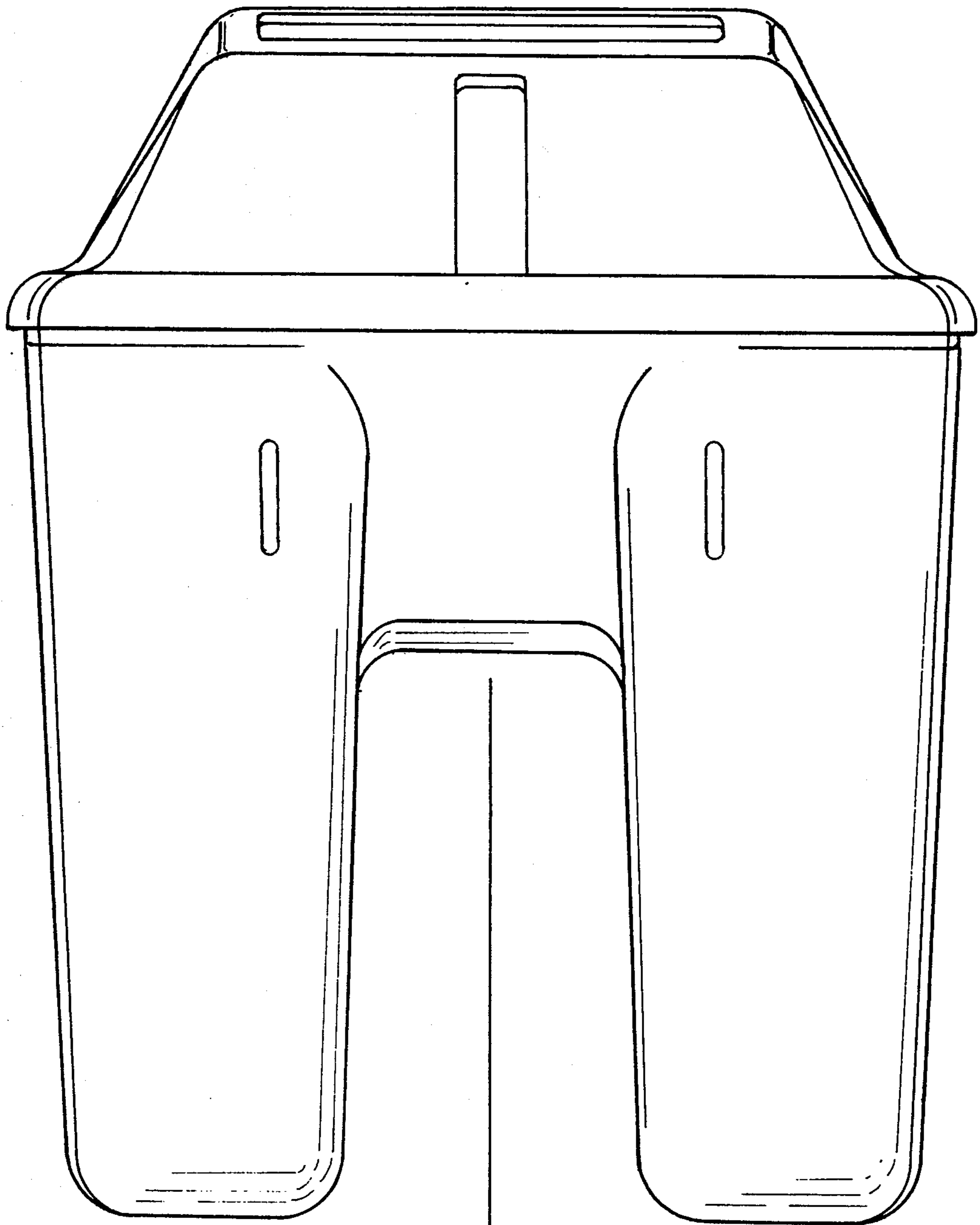
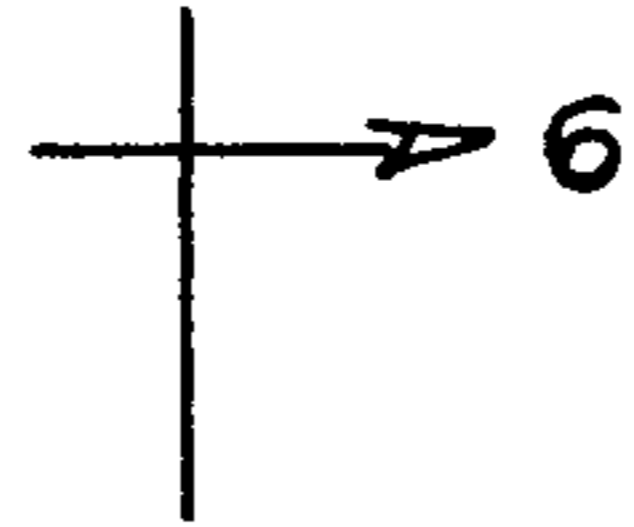

FIG. 5.

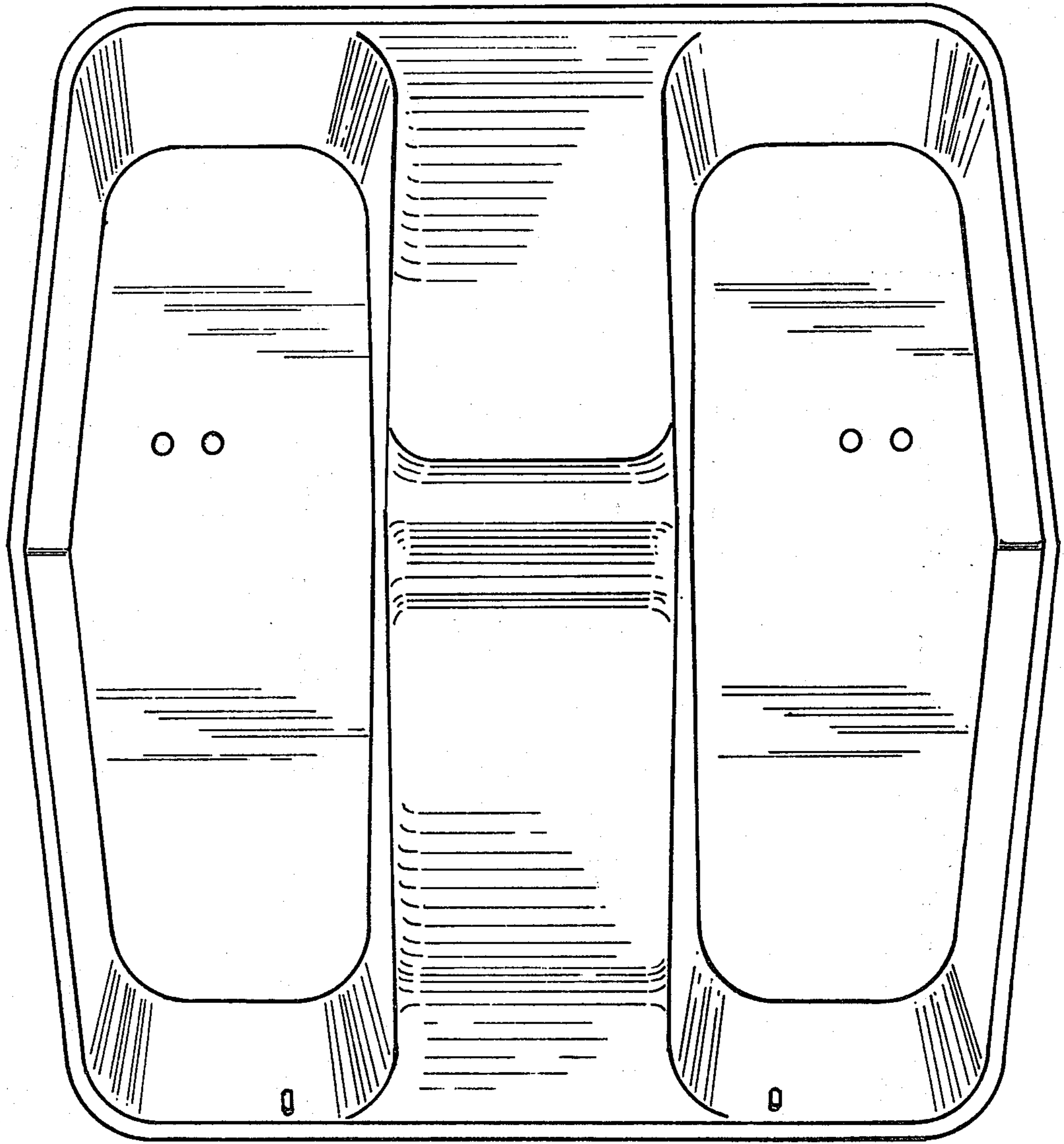

FIG. 6.

