

[54] COMBINED FOLDING SEAT AND SHOPPING BAG

[76] Inventor: Marcia B. Bockus, 1036 Park Ave., New York, N.Y. 10028

[**] Term: 14 Years

[21] Appl. No.: 286,179

[22] Filed: Oct. 29, 1981

[52] U.S. Cl. D6/64; D3/43; D3/71; D6/4

[58] Field of Search D6/64, 42, 45, 178, D6/32; D3/43, 71; 190/8, 12 A, 12 R; 297/118, 119, 16, 17

[56] References Cited

U.S. PATENT DOCUMENTS

- D. 199,871 12/1964 Lanigan D6/178 X
- D. 259,075 5/1981 Solomon D3/71
- D. 263,176 3/1982 Harrington D3/71
- 1,444,455 2/1923 Brown et al. 190/12 A

- 1,850,636 3/1932 Schaver 190/12 R
- 1,864,648 6/1932 Haines D6/201 X
- 2,868,274 1/1959 Miller 190/8
- 4,273,221 6/1981 Poag 190/8

Primary Examiner—Bruce W. Dunkins

[57] CLAIM

The ornamental design for a combined folding seat and shopping bag, substantially as shown and described.

DESCRIPTION

FIG. 1 is a perspective view of an ornamental design for a combined folding seat and shopping bag, shown closed;

FIG. 2 is similar to FIG. 1, but illustrates the legs folded outwards, with the leg covers unzipped;

FIG. 3 is a left end view of FIG. 1, shown in elevation with the carrying handles in raised position;

FIG. 4 is a rear view of FIG. 1, shown in elevation;

FIG. 5 is a top plan view of FIG. 1, showing the interior of the seat portion, for use as a shopping bag, and

FIG. 6 is a bottom plan view of FIG. 1.

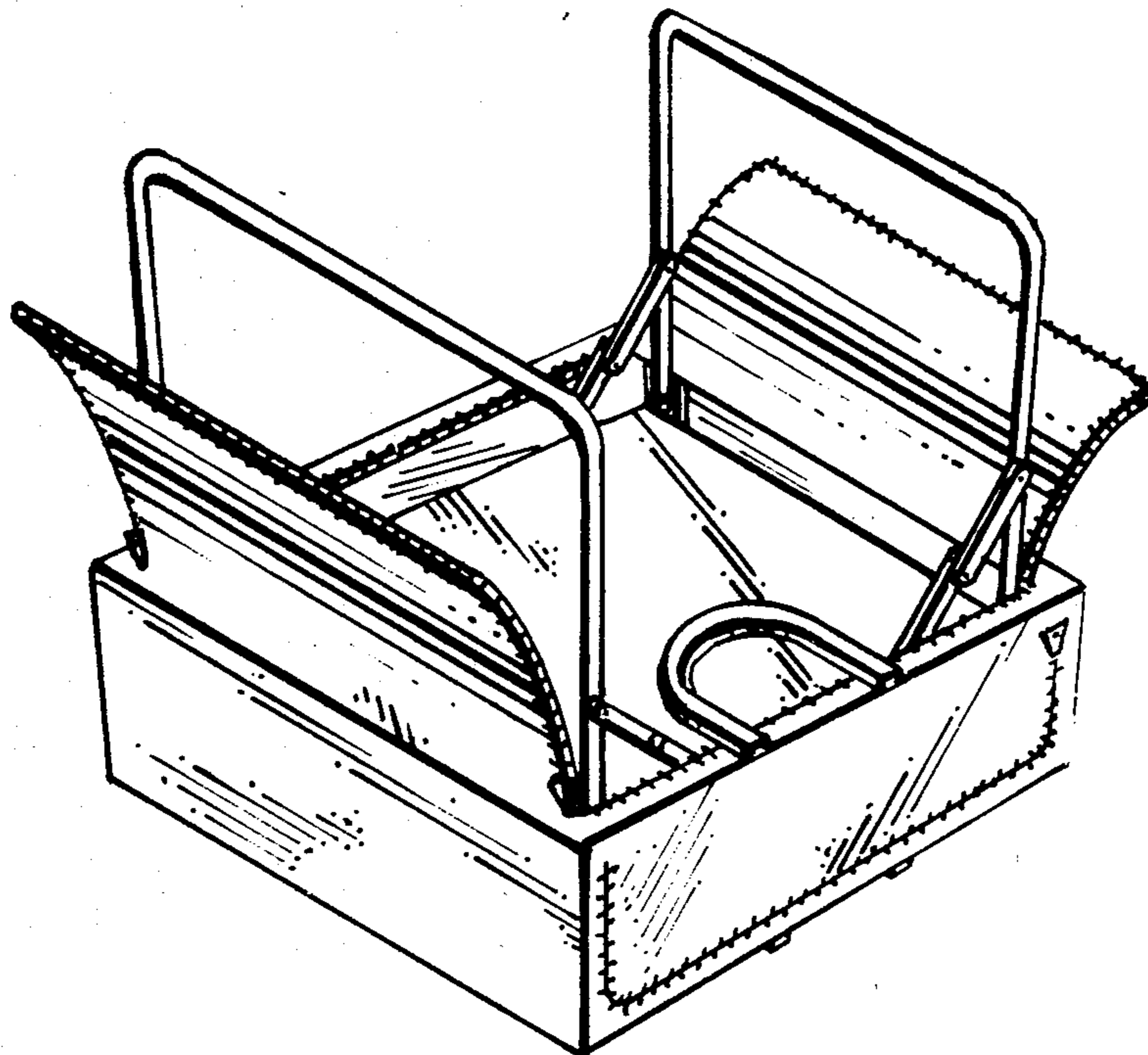

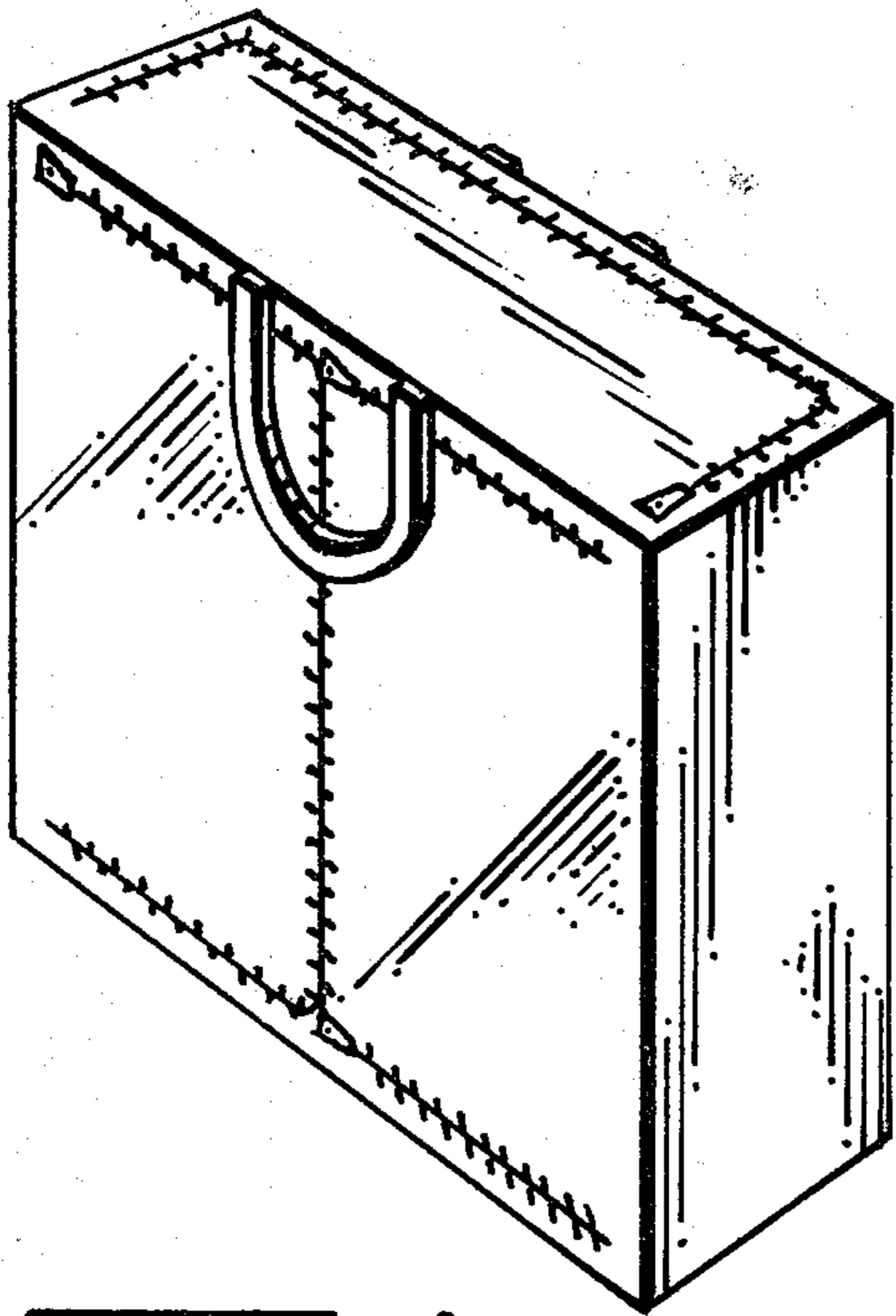

FIG. 1

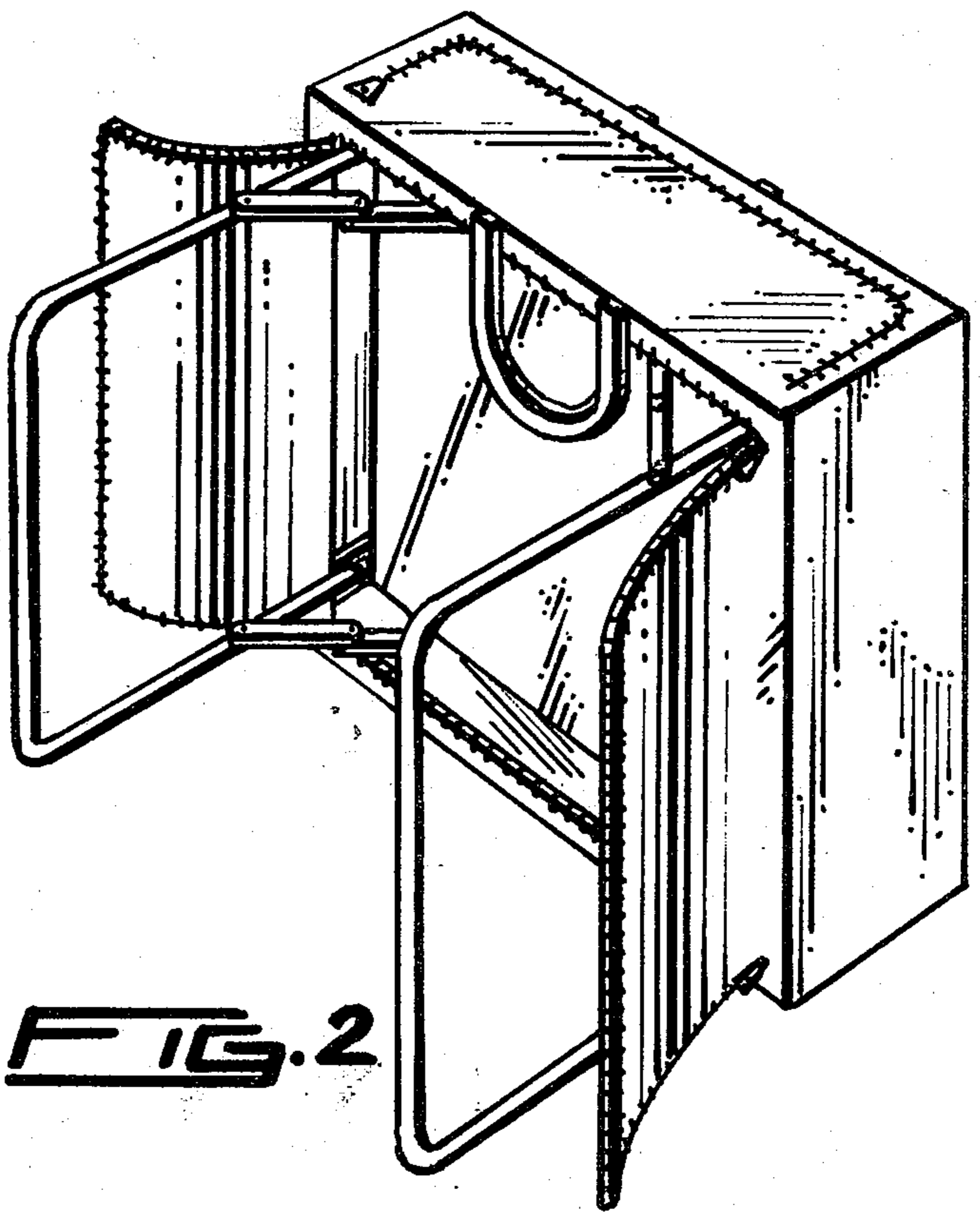

FIG. 2

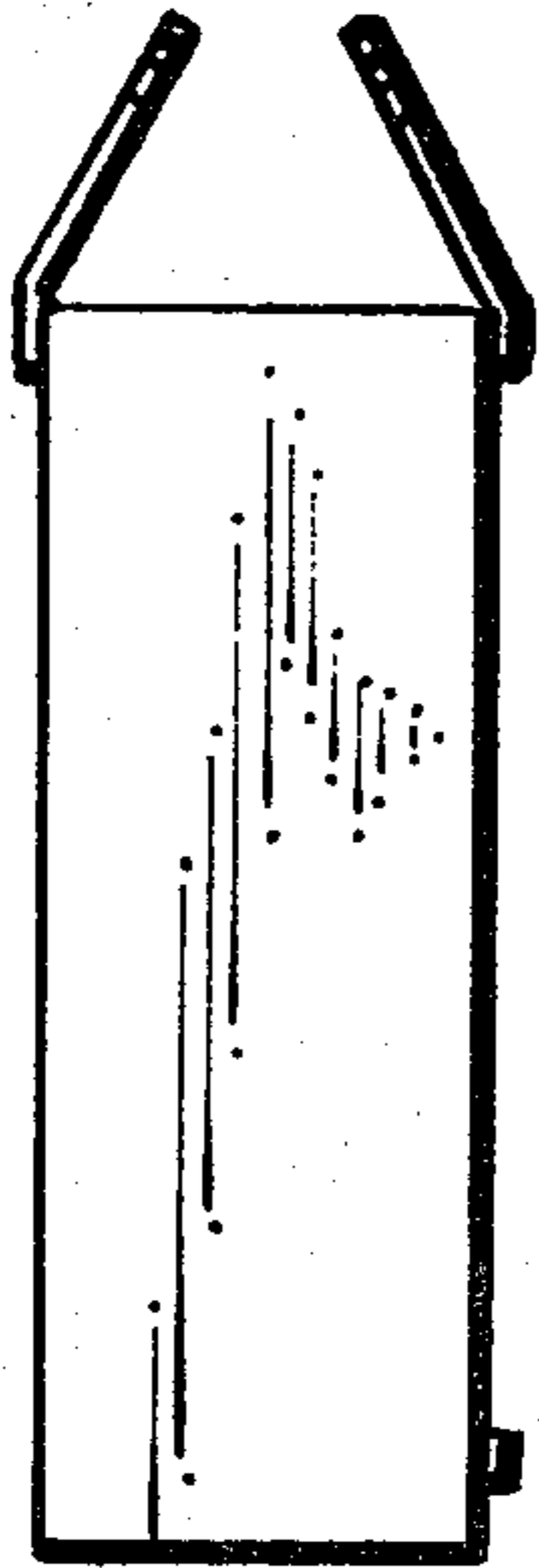

FIG. 3

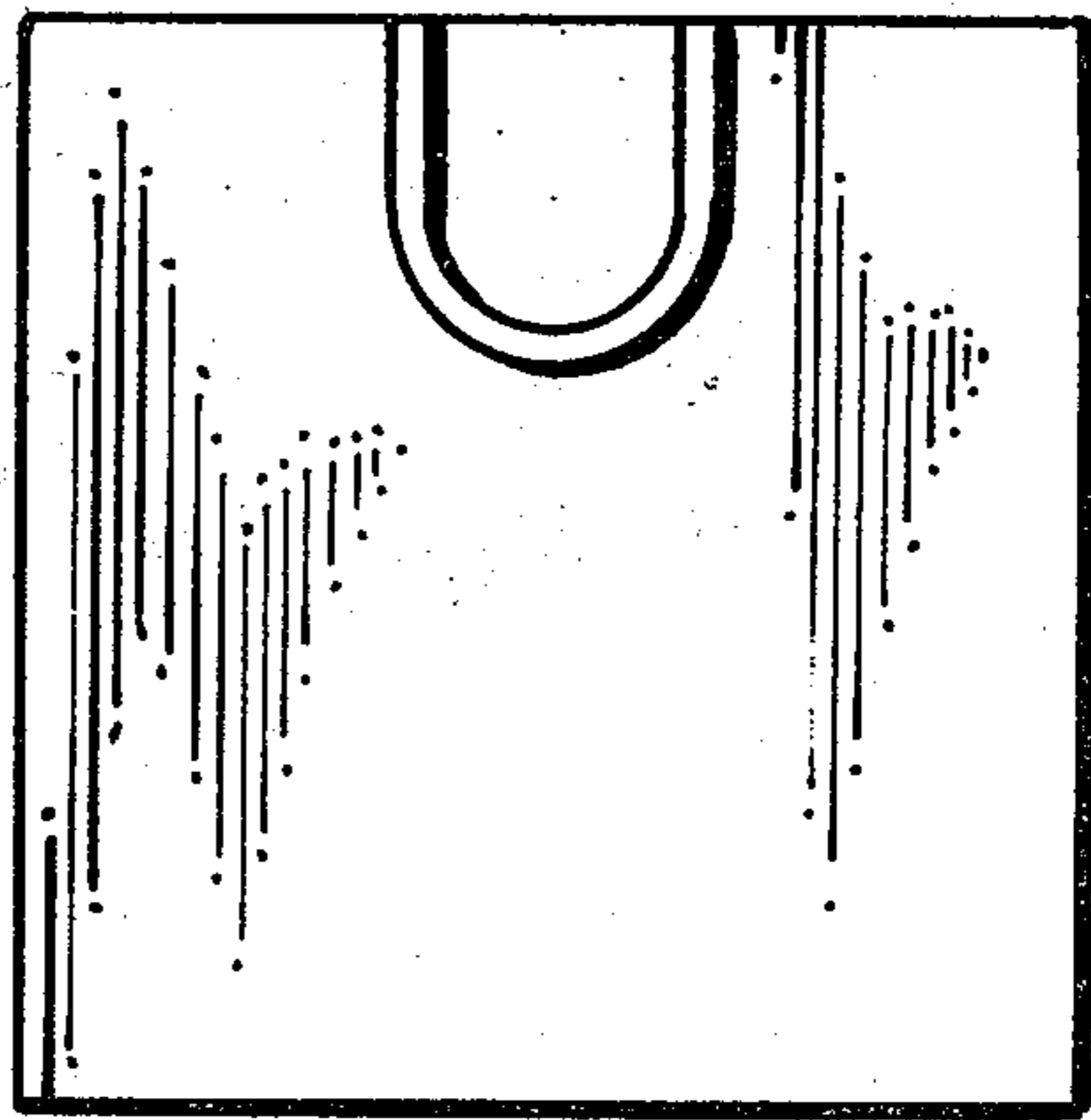

FIG. 4

FIG. 5

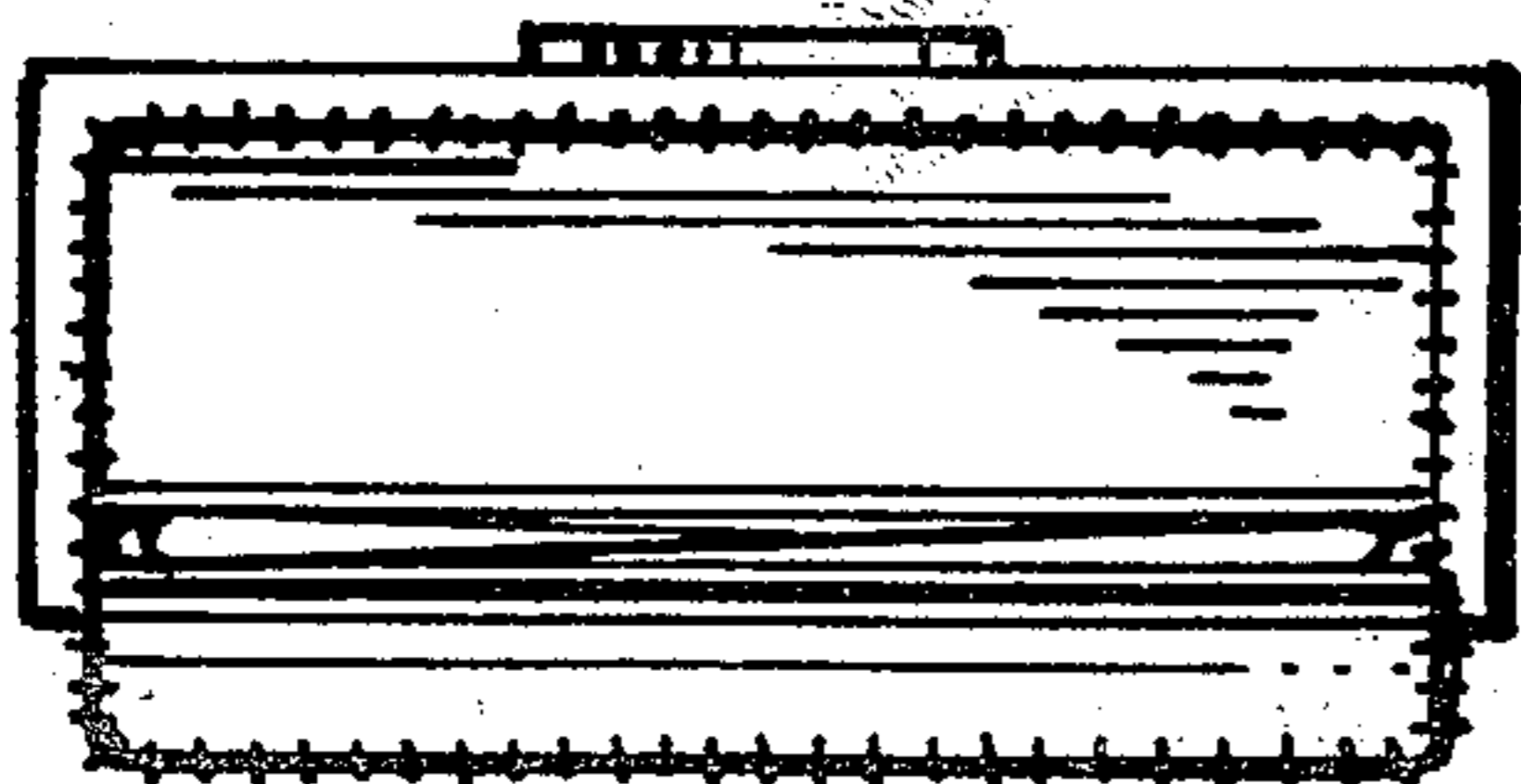

FIG. 6

