

[54] SAFETY FLUSH VALVE FITTING FOR AUTOMOTIVE AIR CONDITIONER

[76] Inventor: Harrison Burruss, 3120 Teton Cir., Huntsville, Ala. 35810

[**] Term: 14 Years

[21] Appl. No.: 293,287

[22] Filed: Aug. 17, 1981

[52] U.S. Cl. D23/21

[58] Field of Search D23/19, 20, 21, 22; 251/148

D. 260,280	8/1981	Campbell	D23/22
D. 264,616	5/1982	Hull	D23/34
1,081,968	12/1913	Kitts, Jr.	251/148
3,890,999	6/1975	Moskow	251/148 X

Primary Examiner—Catherine E. Kemper
Attorney, Agent, or Firm—C. A. Phillips

[57] CLAIM

The ornamental design for a safety flush valve fitting for an automotive air conditioner, substantially as shown and described.

DESCRIPTION

FIG. 1 is an end elevational view of a safety flush valve fitting for an automotive air conditioner, showing my new design;

FIG. 2 is a perspective view taken from the end opposite that shown in FIG. 1;

FIG. 3 is a perspective view taken from the end opposite that shown in FIG. 2.

[56] References Cited

U.S. PATENT DOCUMENTS

D. 119,175	2/1940	Shaw	D23/21 X
D. 121,785	8/1940	Ernst	D23/19
D. 180,992	9/1957	Britton	D23/20
D. 217,246	4/1970	Armand	D23/21

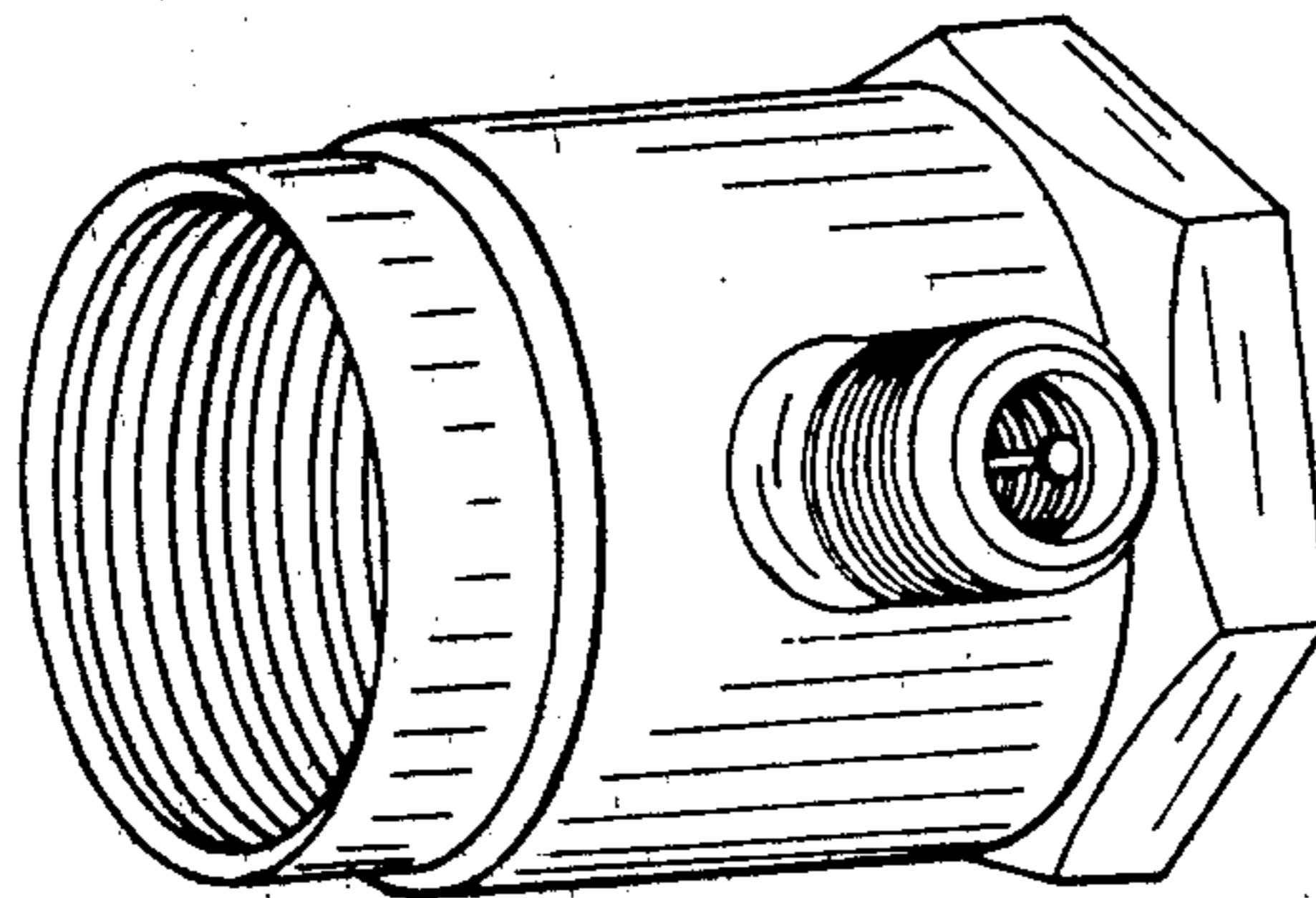
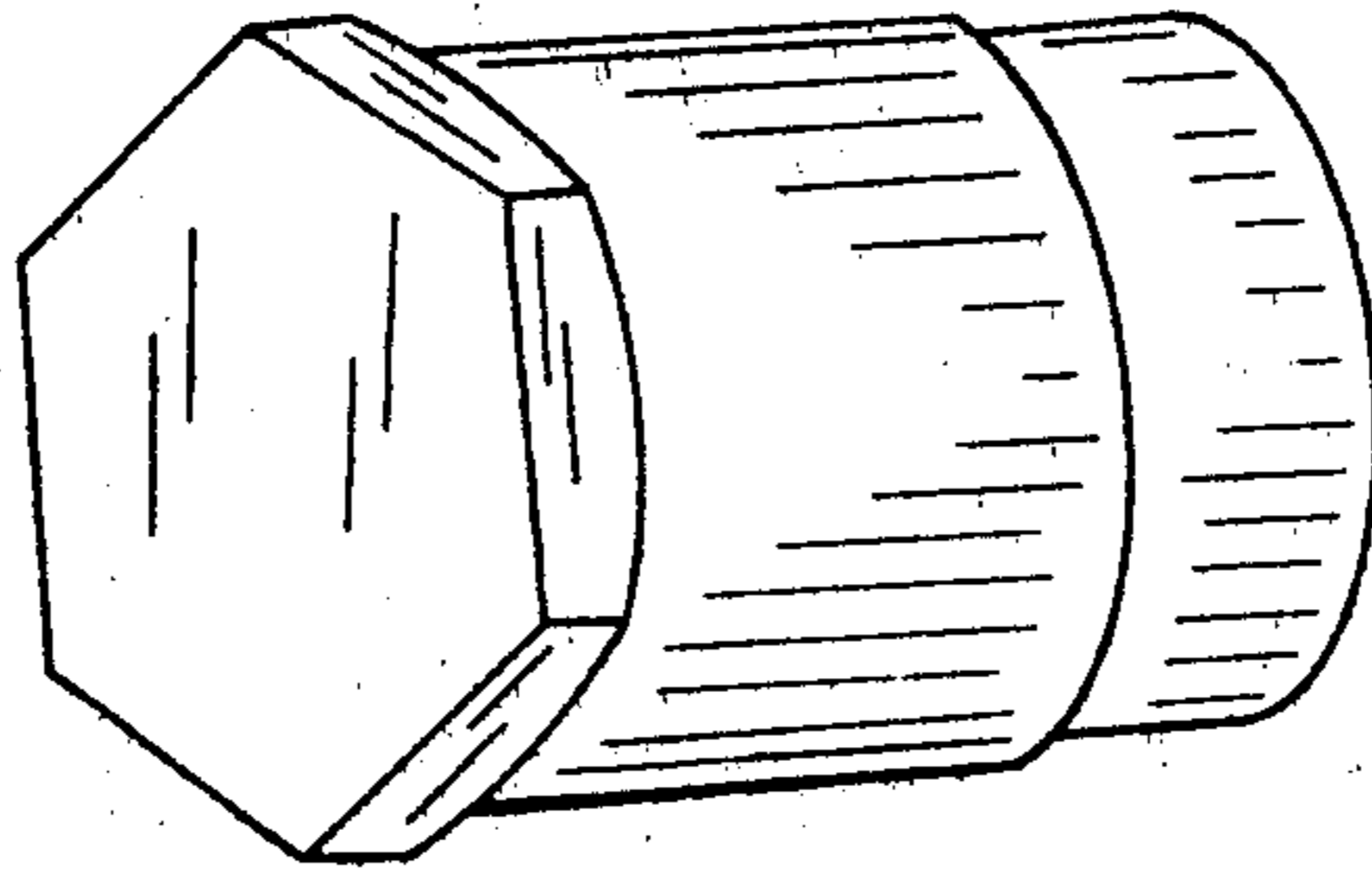

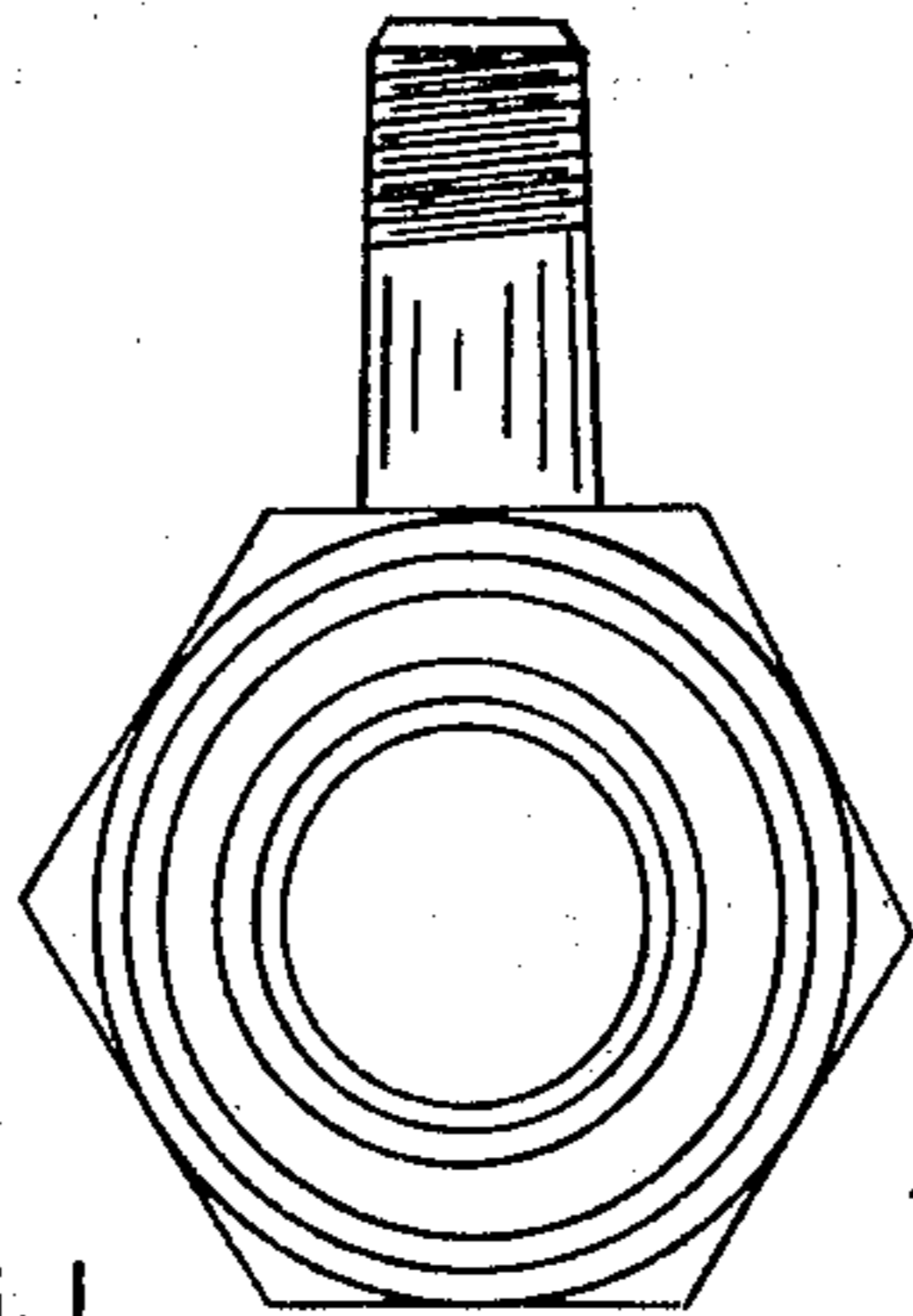

FIG. 1

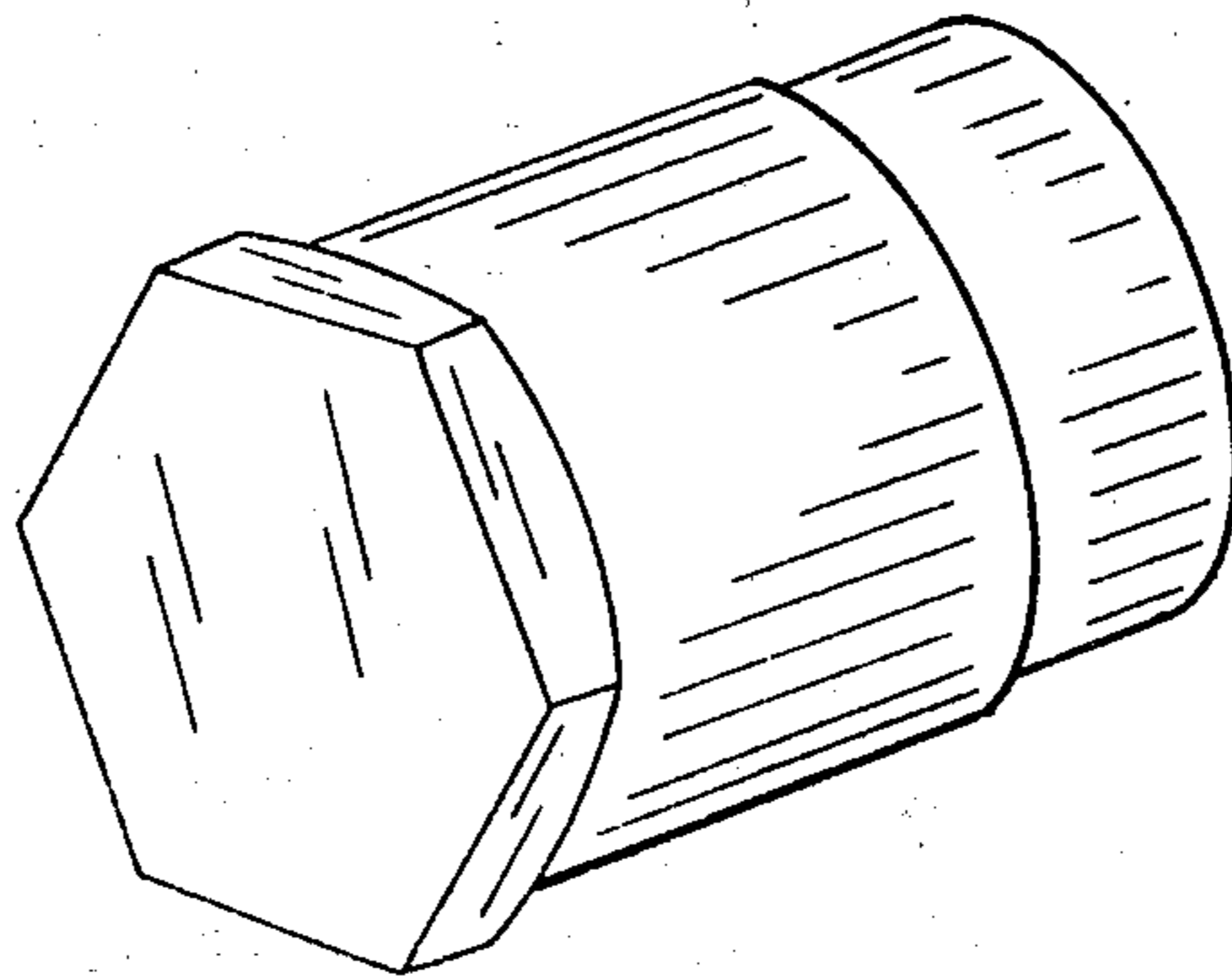

FIG. 2

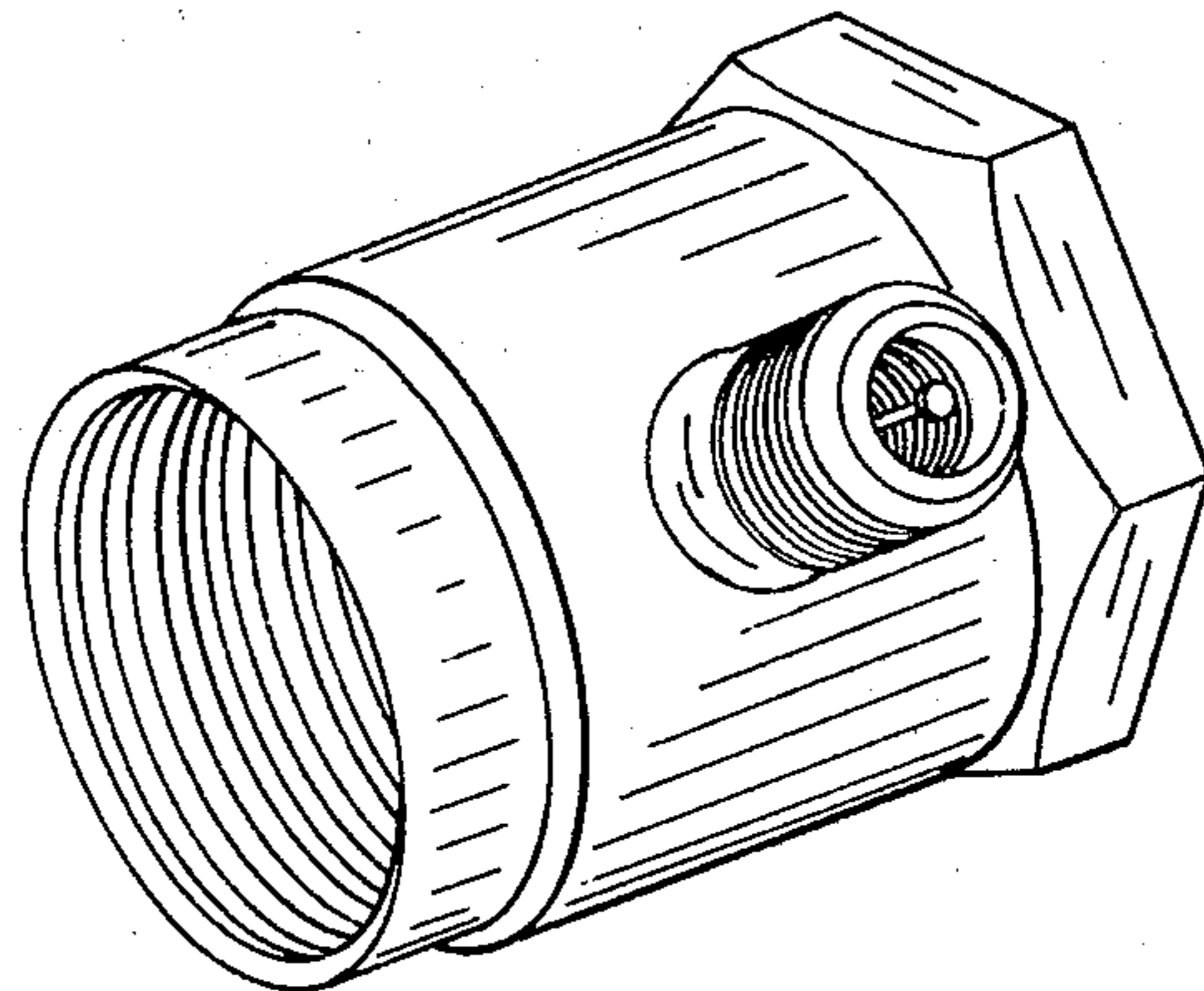

FIG. 3