

[54] MOTORCYCLE

[75] Inventors: Masato Iwakura, Asaka; Mutsuo Hirose; Toshiyuki Yamada, both of Niiza, all of Japan

[73] Assignee: Honda Giken Kogyo Kabushiki Kaisha, Tokyo, Japan

[**] Term: 14 Years

[21] Appl. No.: 450,731

[22] Filed: Dec. 17, 1982

[30] Foreign Application Priority Data

Jun. 22, 1982 [JP] Japan 57/28084

[52] U.S. Cl. D12/110

[58] Field of Search D12/110; 180/219

[56] References Cited

PUBLICATIONS

Cycle World, 2/80, pp. 12 & 13, Harley-Davidson Motorcycle.

Cycle World, 3/81, p. 145, Yamaha Motorcycle, center of page.

Cycle World, 6/81, p. 45, Yamaha 750 Seca, top of page.

Cycle World, 12/81, p. 74, Honda Motorcycle, center left side of page.

Extract from the Enlarged Issue of Japanese Magazine Entitled "Motorcyclist", Apr. 1, 1982, pp. 76 and 77.

Extract from the Extra Issue of Japanese Magazine Entitled "Motorcyclist", Nov. 1, 1979, pp. - unknown.

Primary Examiner—James M. Gandy
Attorney, Agent, or Firm—Armstrong, Nikaido, Marmelstein & Kubovcik

[57] CLAIM

The ornamental design for a motorcycle, as shown and described.

DESCRIPTION

FIG. 1 is a left side elevational view of a motorcycle, showing our new design;

FIG. 2 is a right side elevational view thereof;

FIG. 3 is a front elevational view thereof;

FIG. 4 is a rear elevational view thereof;

FIG. 5 is a top plan view thereof;

FIG. 6 is a bottom plan view thereof; and

FIG. 7 is a perspective view thereof.

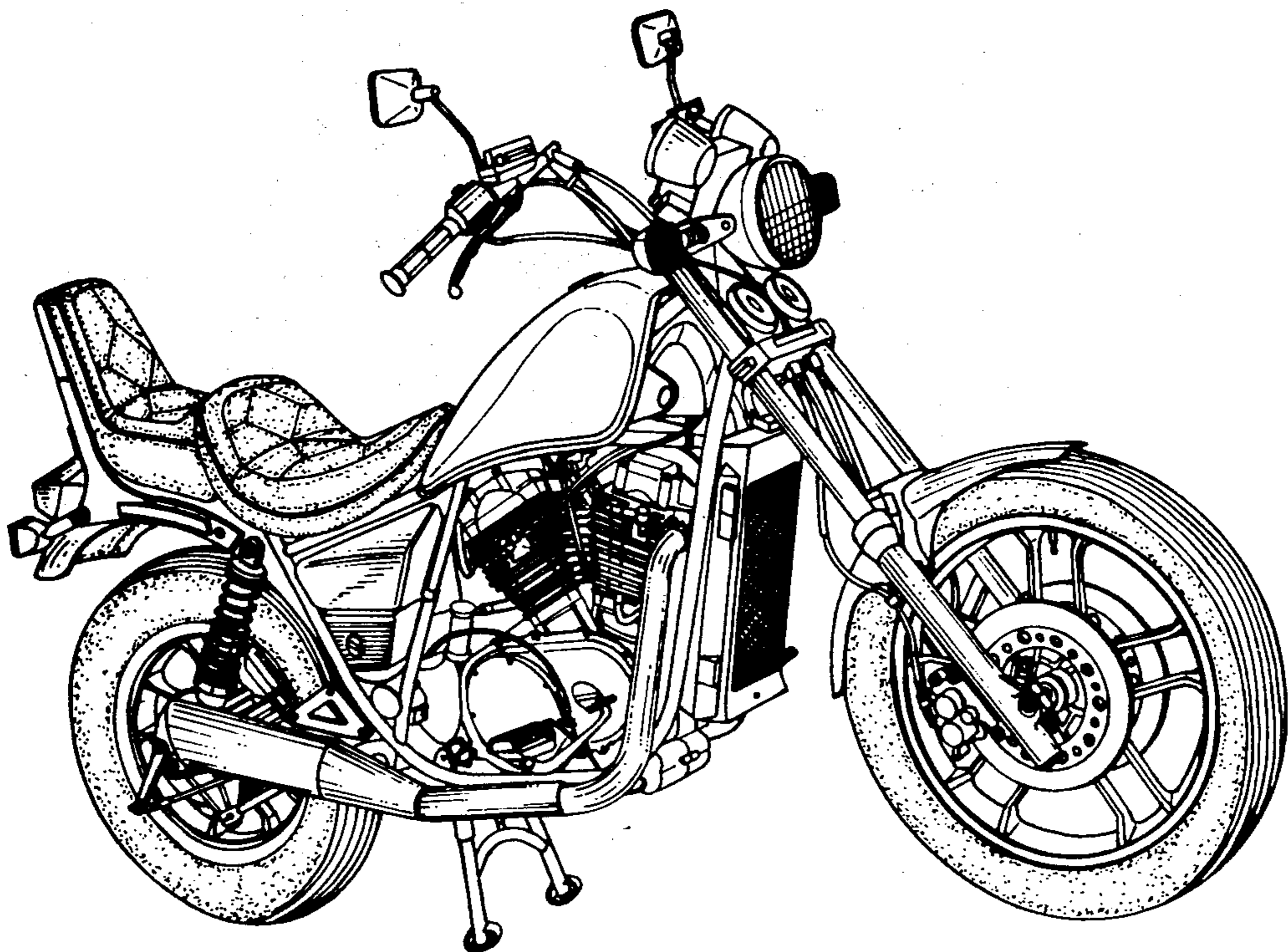

FIG. 1

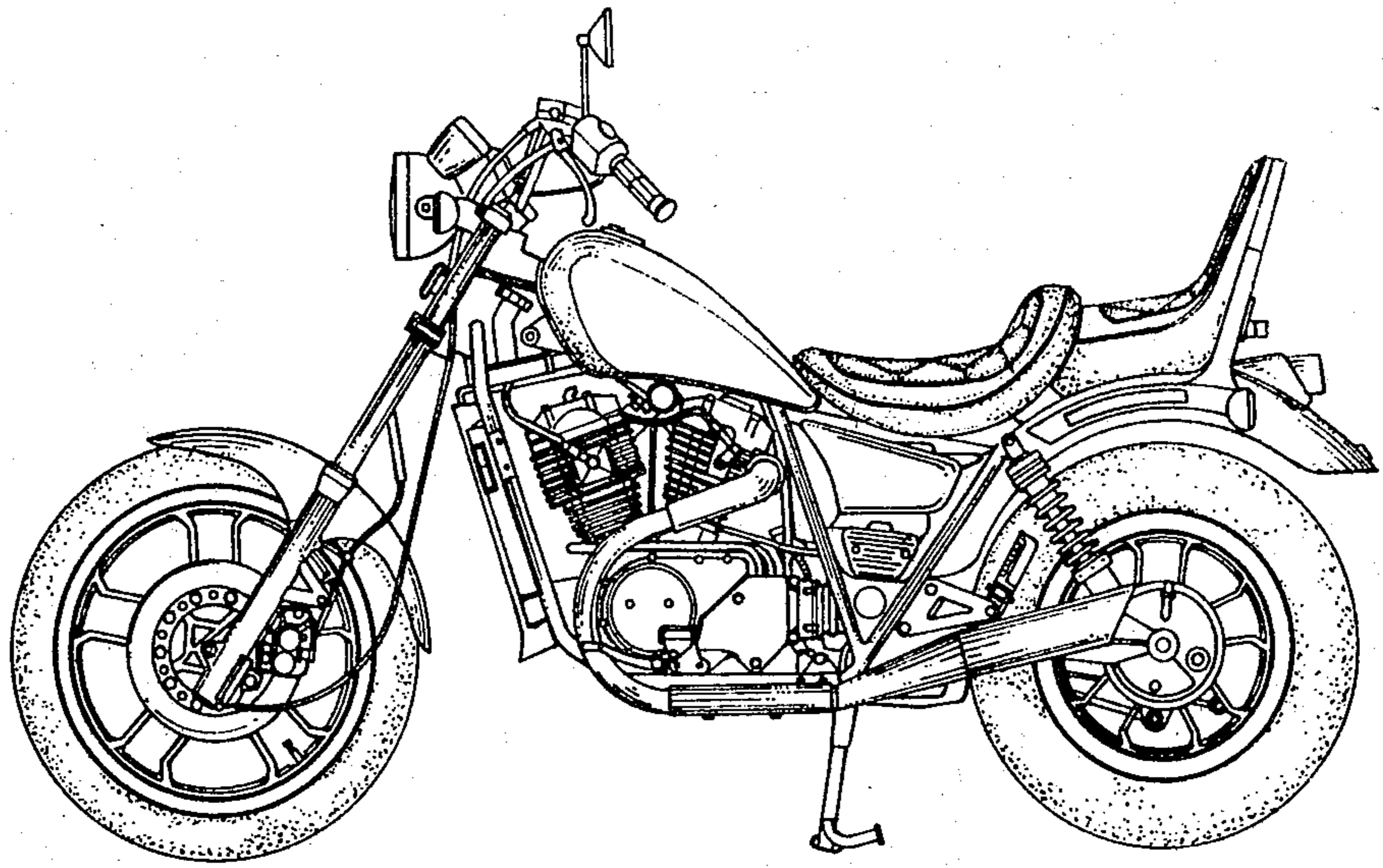

FIG. 2

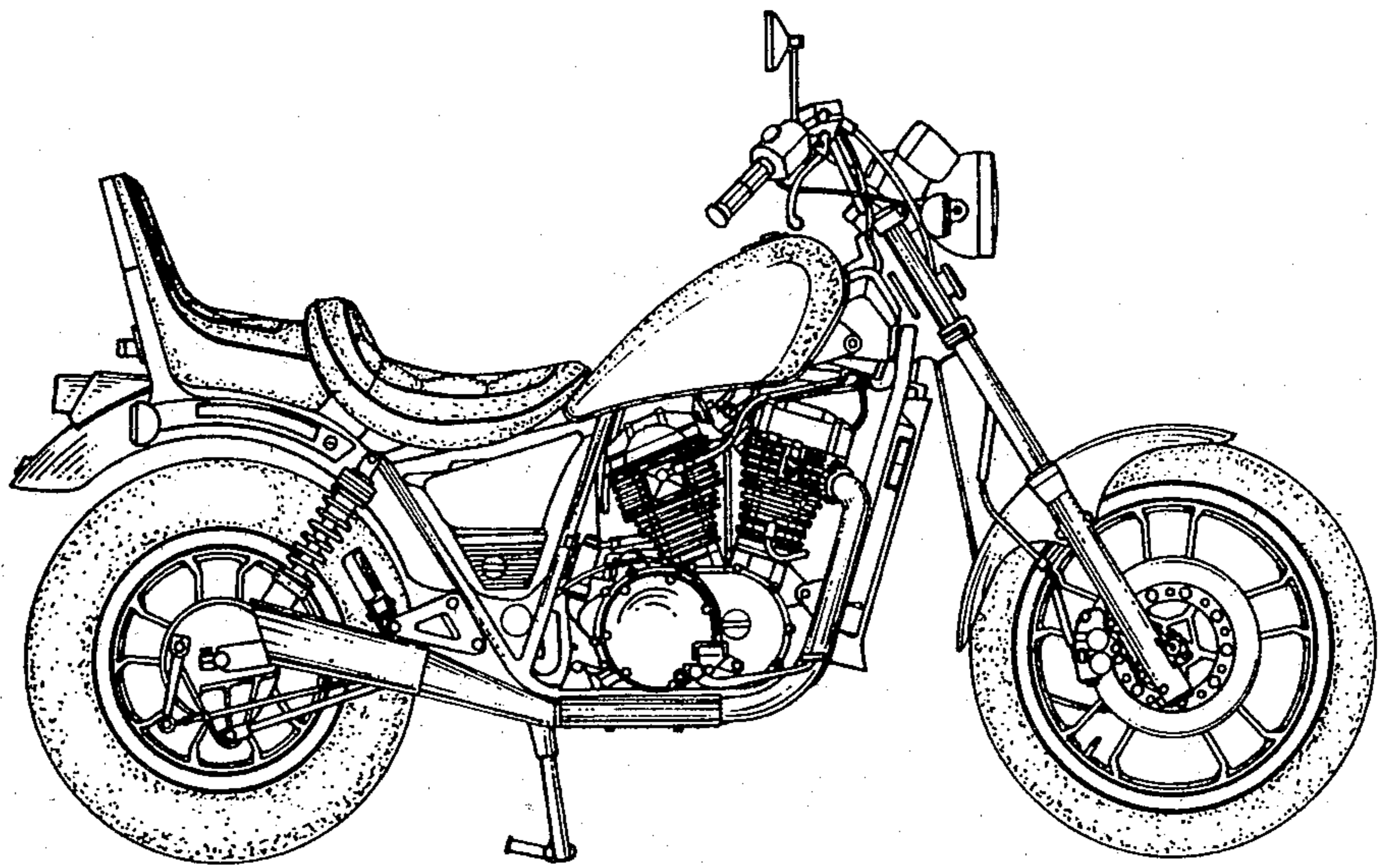

FIG. 3

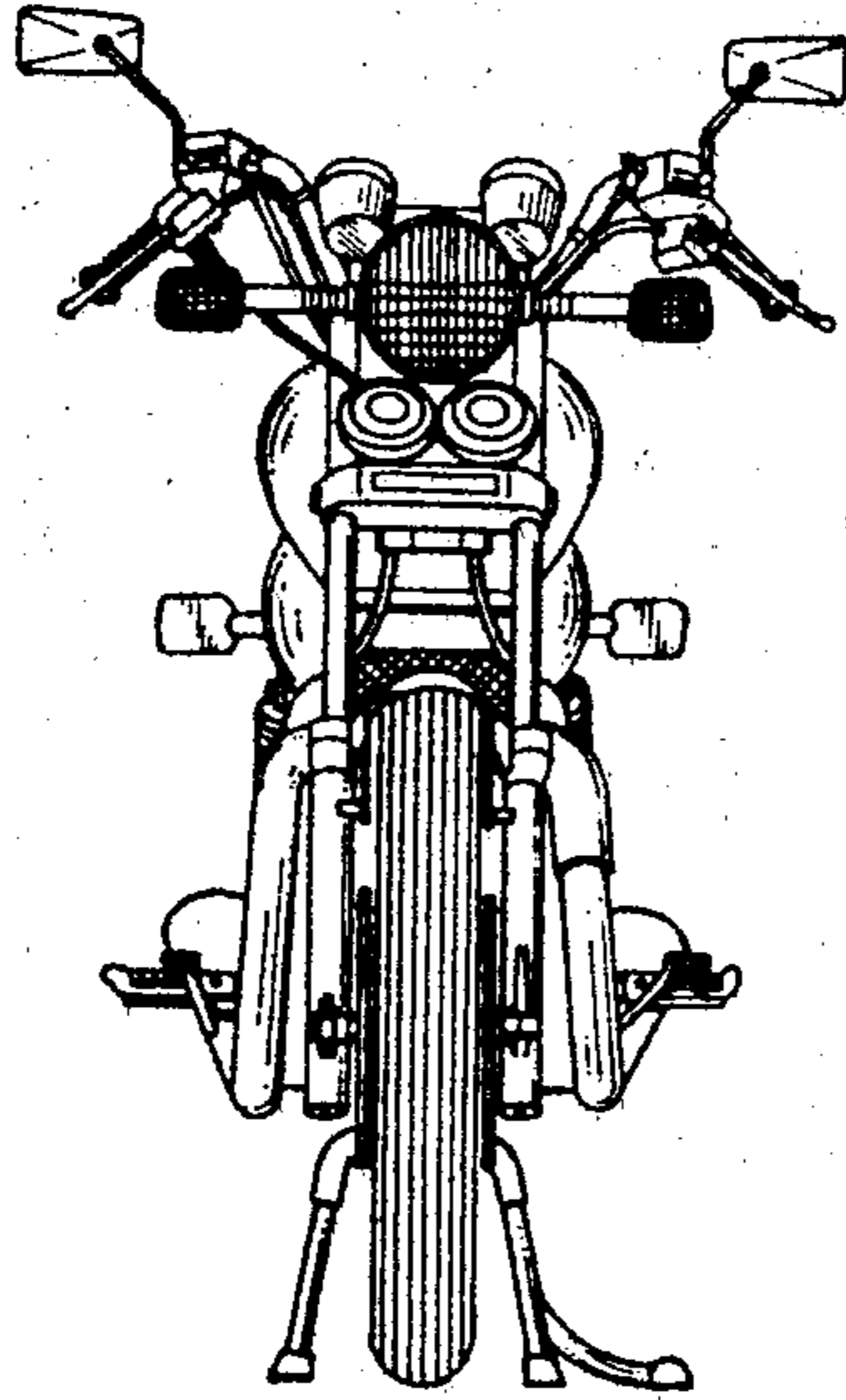

FIG. 4

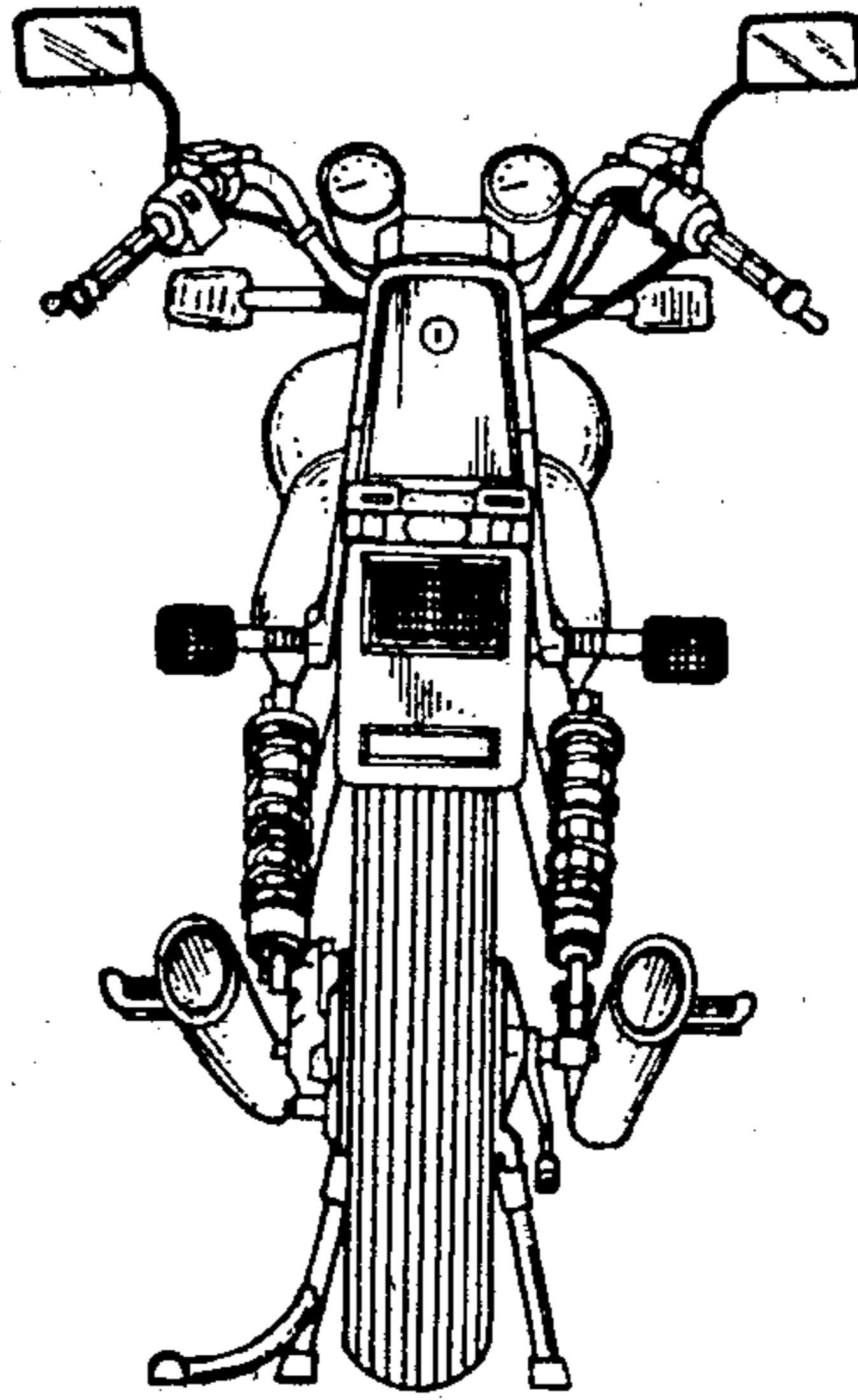

FIG. 5

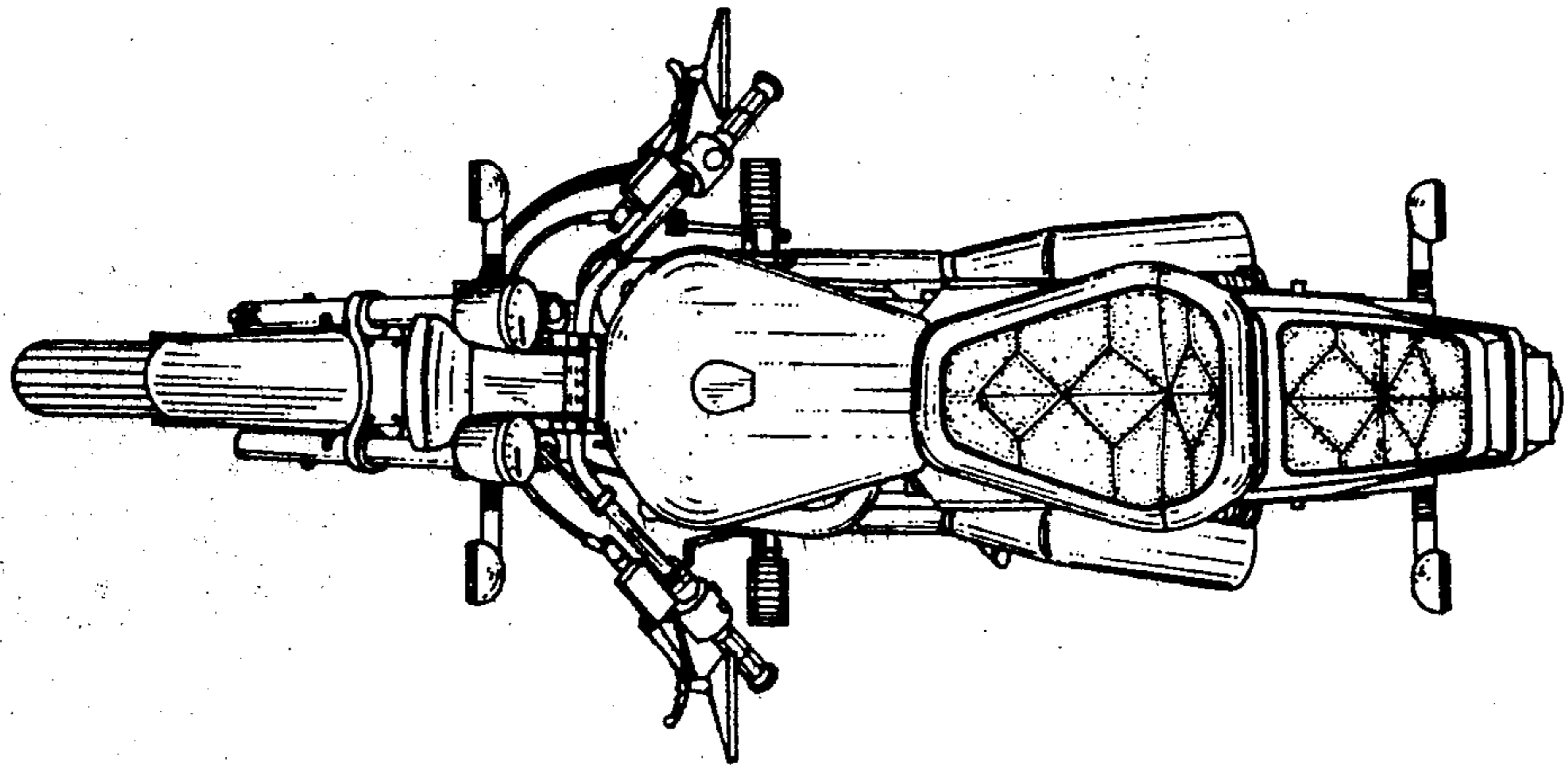

FIG. 6

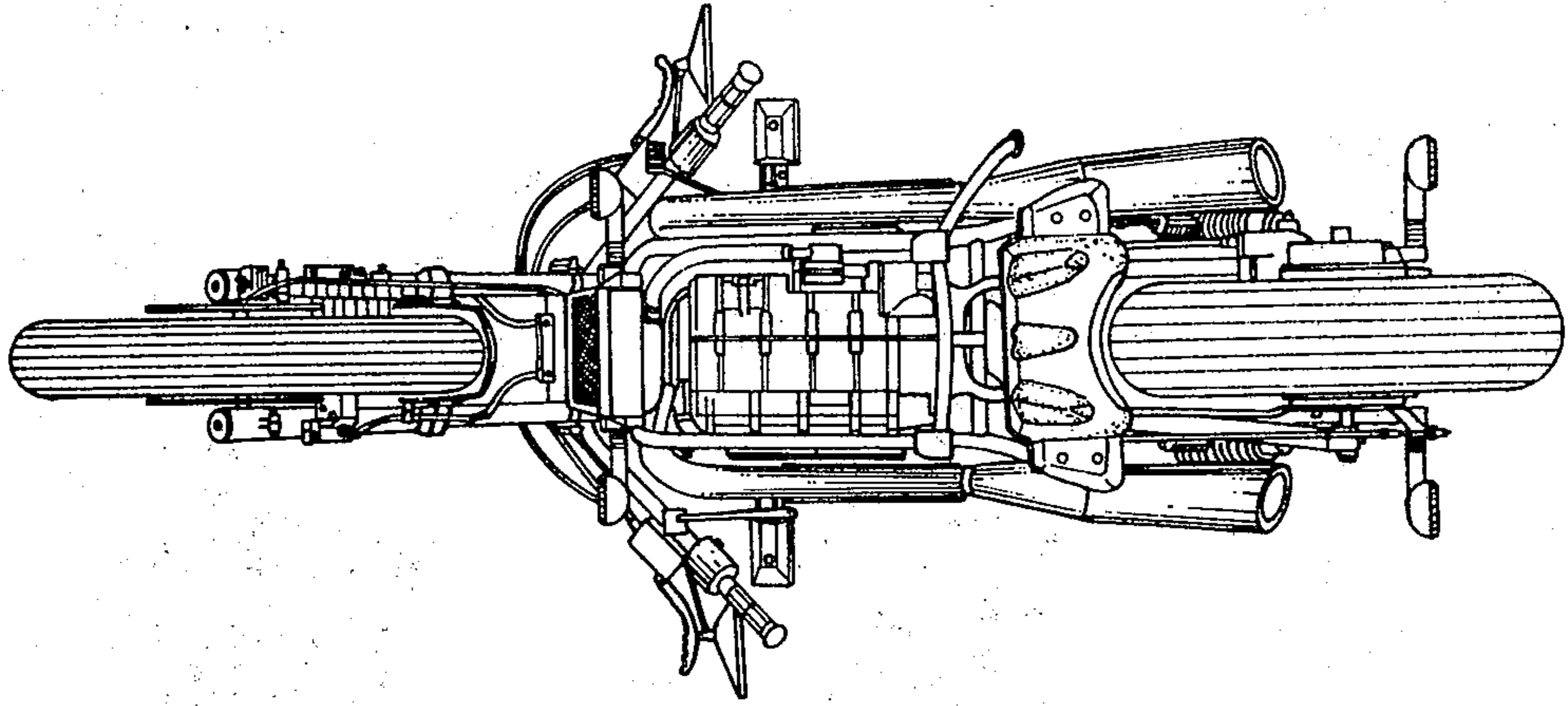

FIG. 7

