

[54] AIR PRECLEANER FOR AN INTERNAL COMBUSTION ENGINE

4,201,557 5/1980 Petersen 55/337

[76] Inventor: Ross K. Petersen, c/o Medalie Manufacturing Co. 4701 Humboldt Ave. N., Minneapolis, Minn. 55430

[**] Term: 14 Years

[21] Appl. No.: 289,045

[22] Filed: Jul. 31, 1981

[52] U.S. Cl. D15/5

[58] Field of Search D15/5; 123/198 E, 142, 123/153; 55/337, 418, 419, DIG. 28, 327, 391, 396, 398, 430, 449, 385 B; D23/153, 138

[56] References Cited

U.S. PATENT DOCUMENTS

D. 84,661	7/1931	Shurtleff	D23/137
D. 176,874	2/1956	Mattke	D23/153
D. 247,250	2/1978	Miller	D23/153
1,309,037	7/1919	Lichty et al.	D23/153
4,159,899	7/1979	Deschenes	55/385 B

OTHER PUBLICATIONS

Goldberg's Marine Catalog, p. 192, Item B, Low Profile Ventilator head member.

Honest Charley & Mr. Cycle 1975 Catalog, vol. 75-1, p. 29, Item #39-1146, Carburetor Scoop.

Primary Examiner—Wallace R. Burke

Assistant Examiner—Lynn Wilder

Attorney, Agent, or Firm—Leo Gregory

[57] CLAIM

The ornamental design for an air precleaner for an internal combustion engine, as shown and described.

DESCRIPTION

FIG. 1 is a perspective view of an air precleaner for an internal combustion engine showing my new design; FIG. 2 is a side elevational view thereof; FIG. 3 is a top plan view thereof; FIG. 4 is a bottom plan view thereof; FIG. 5 is a rear elevational view thereof; and FIG. 6 is a front elevational view thereof.

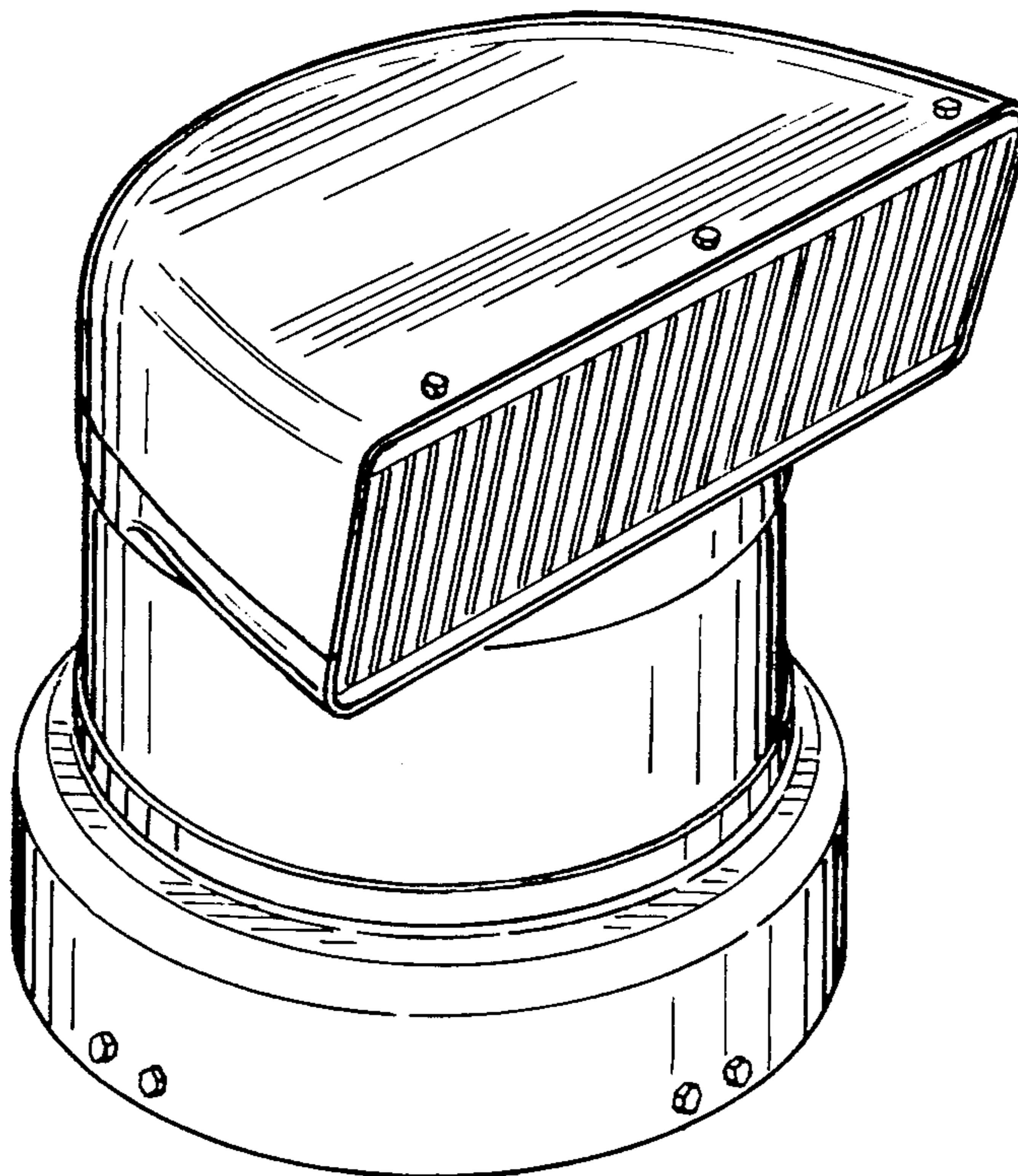

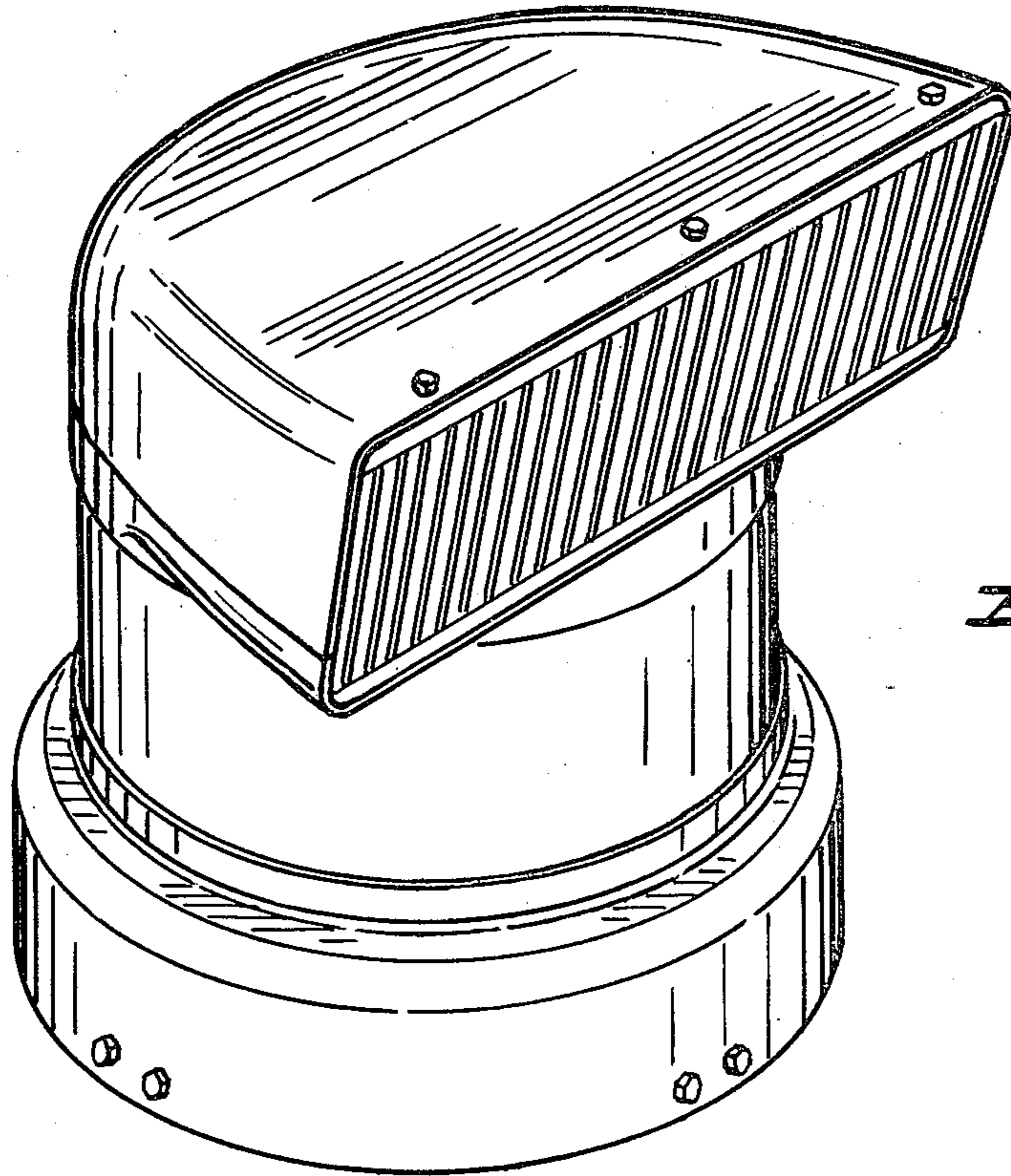

FIG. 1

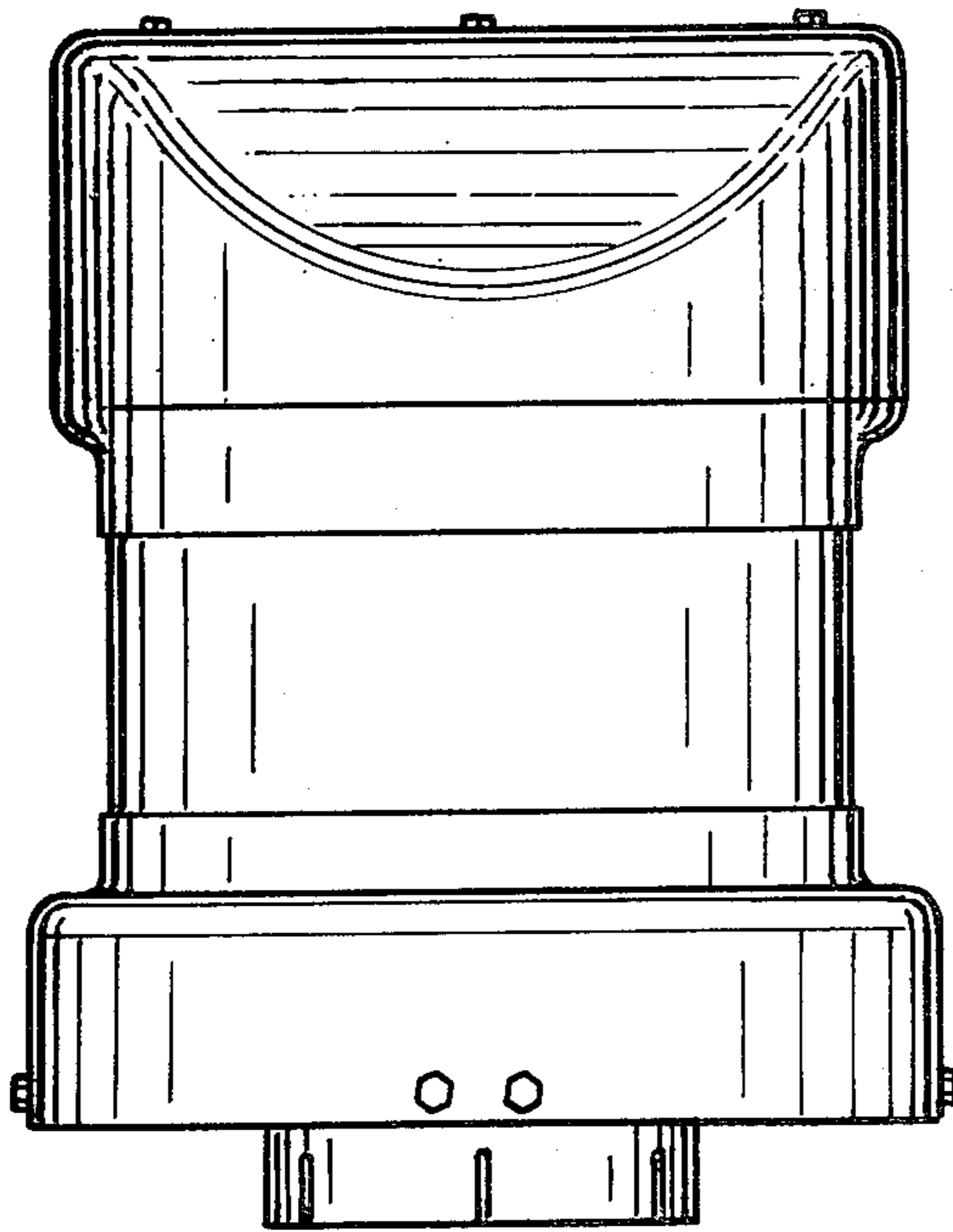

FIG. 5

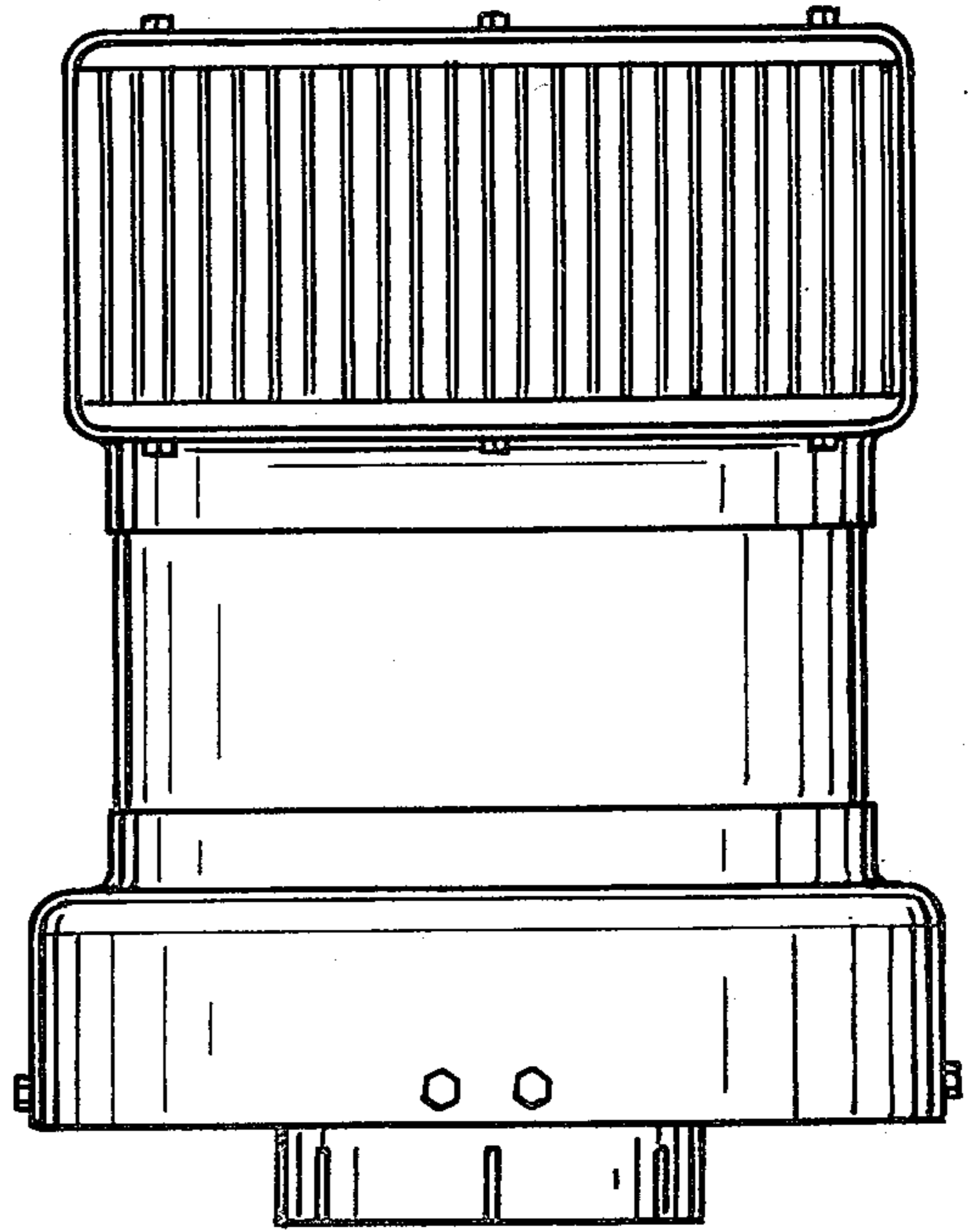

FIG. 6

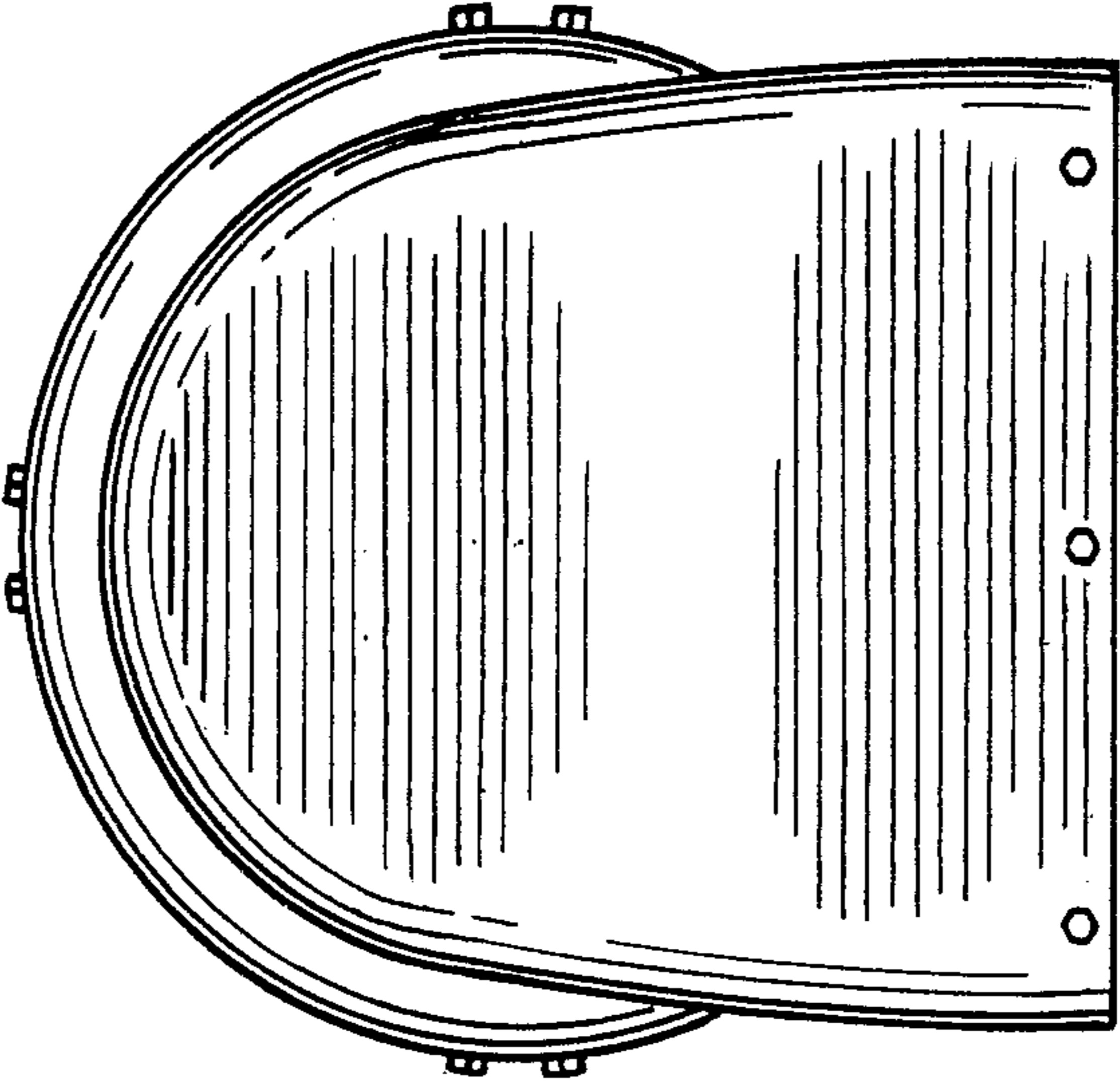

FIG. 3

FIG. 2

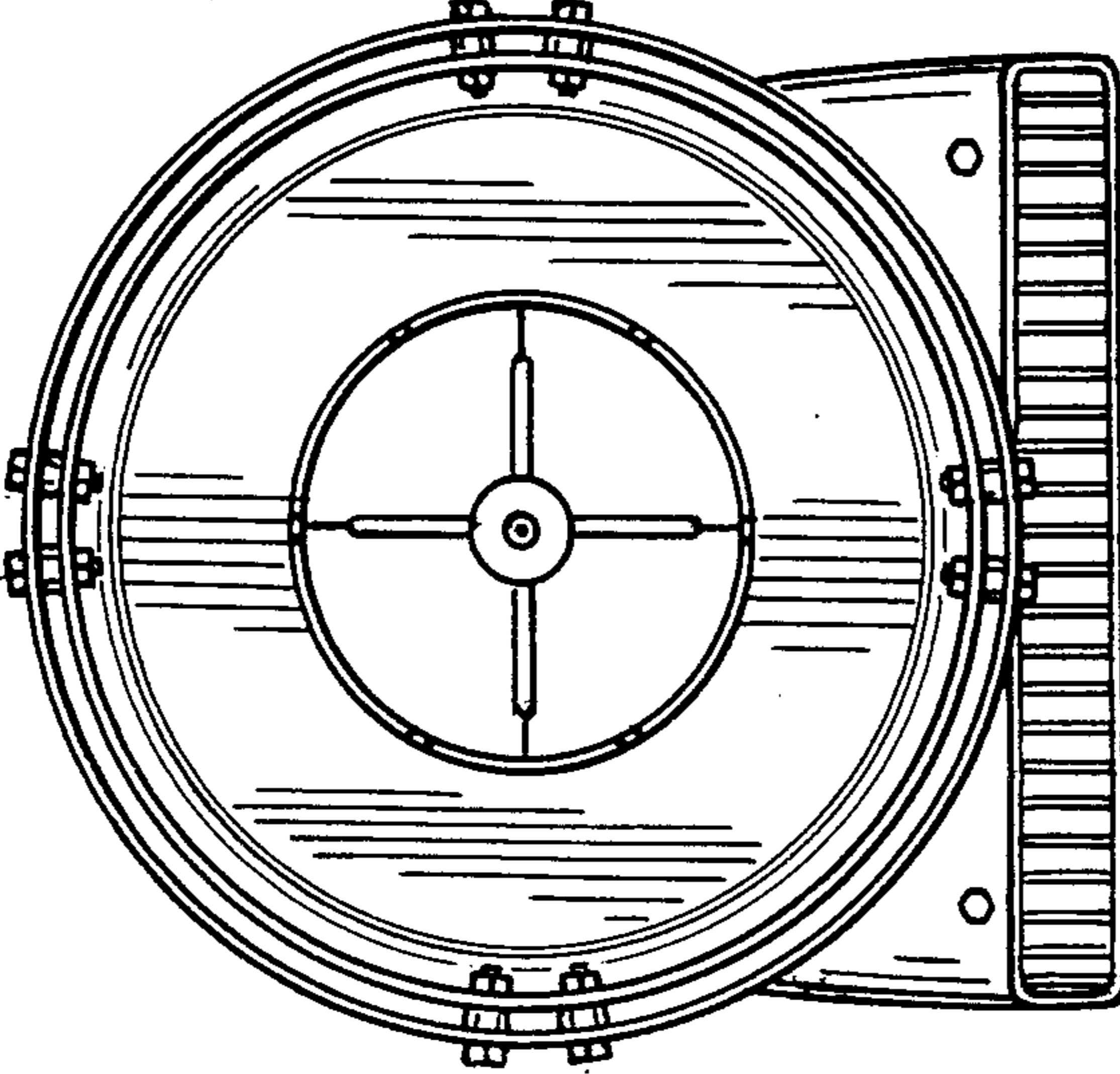
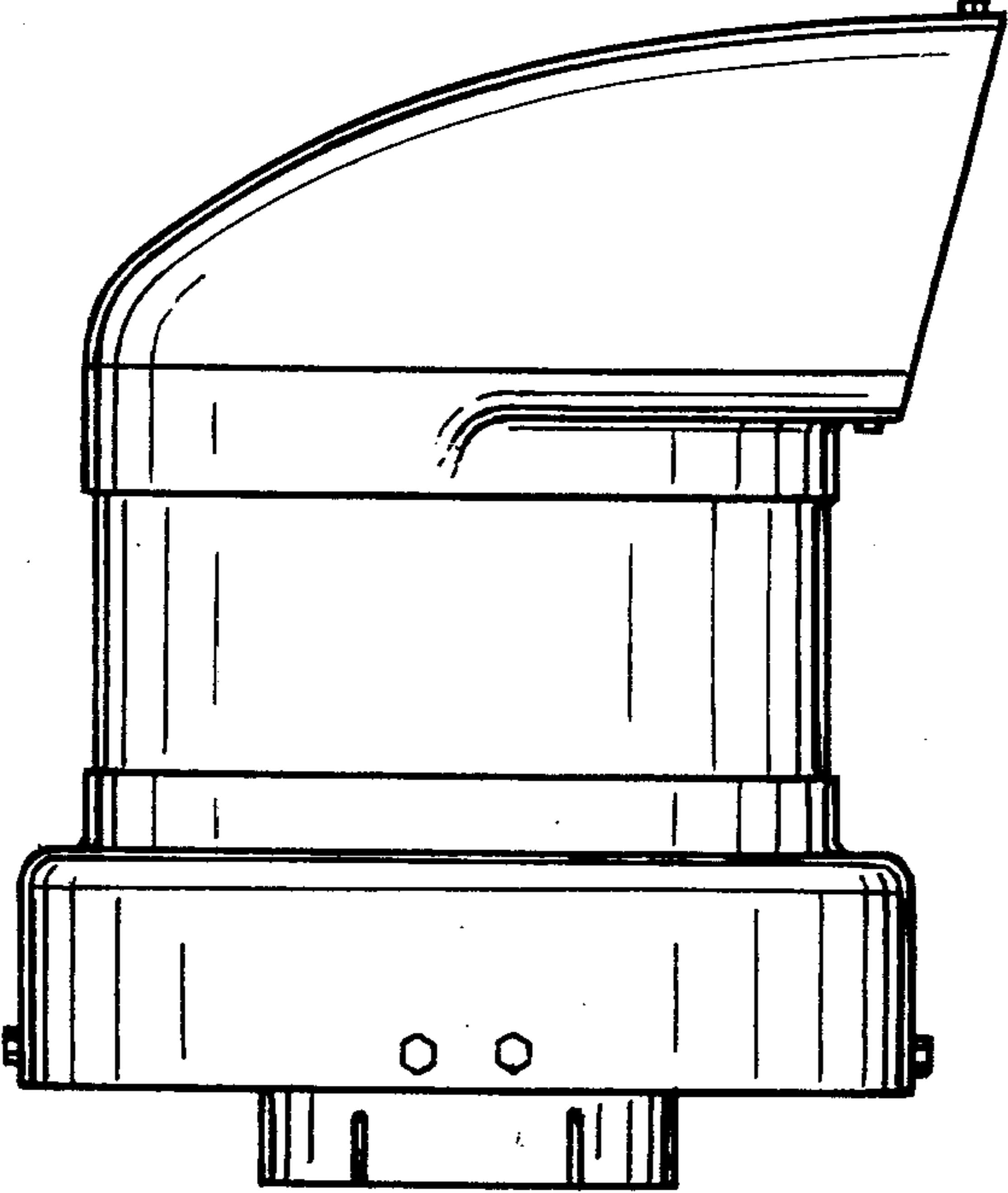

FIG. 4