

[54] MOTORCYCLE

[75] Inventors: **Tsunemi Kawashima**, Tokyo;
Toshiharu Shimizu, Saitama; **Kiyoshi Hashimoto**; **Seiji Higashihara**, both of Shizuoka, all of Japan

[73] Assignee: **Yamaha Hatsudoki Kabushiki Kaisha**, Japan

[**] Term: **14 Years**

[21] Appl. No.: **375,041**

[22] Filed: **May 5, 1982**

[30] Foreign Application Priority Data

Nov. 12, 1981 [JP] Japan 56-50.363

[52] U.S. Cl. D12/110

[58] Field of Search D12/110; 180/219

[56]

References Cited

U.S. PATENT DOCUMENTS

- D. 267,561 1/1983 Ban et al. D12/110
- D. 269,169 5/1983 Ban et al. D12/110
- D. 269,171 5/1983 Ikeda et al. D12/110

OTHER PUBLICATIONS

Testi Brochure, inside front cover, Scooter Amico, bottom of page.

Primary Examiner—James M. Gandy
Attorney, Agent, or Firm—Ostrolenk, Faber, Gerb & Soffen

[57]

CLAIM

The ornamental design for a motorcycle, as shown.

DESCRIPTION

FIG. 1 is a perspective view of a motorcycle showing my new design;
FIG. 2 is a right-side elevational view thereof;
FIG. 3 is a left-side elevational view thereof;
FIG. 4 is a top plan view thereof;
FIG. 5 is a front elevational view thereof; and
FIG. 6 is a back elevational view thereof.

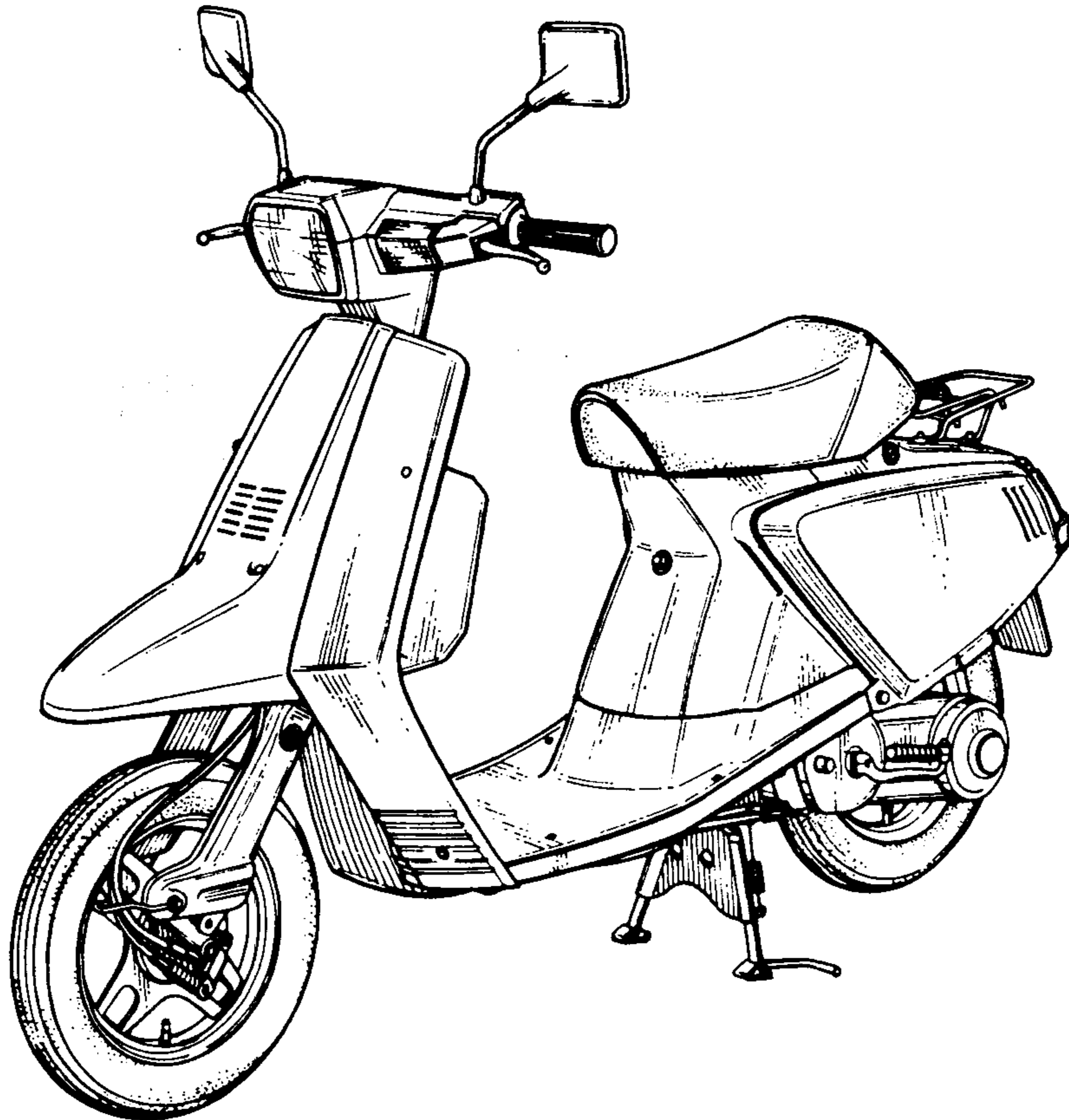

FIG. 1

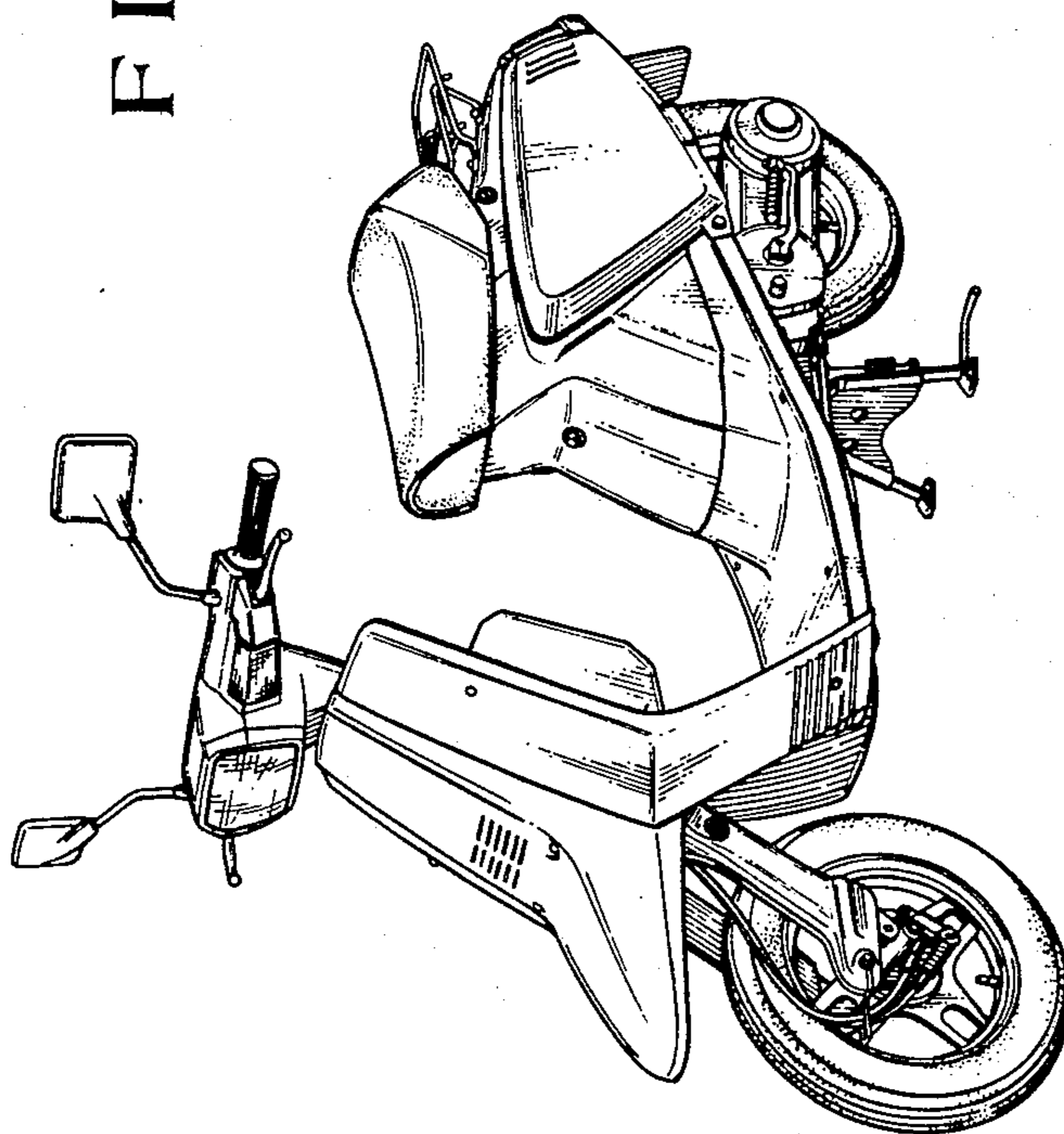
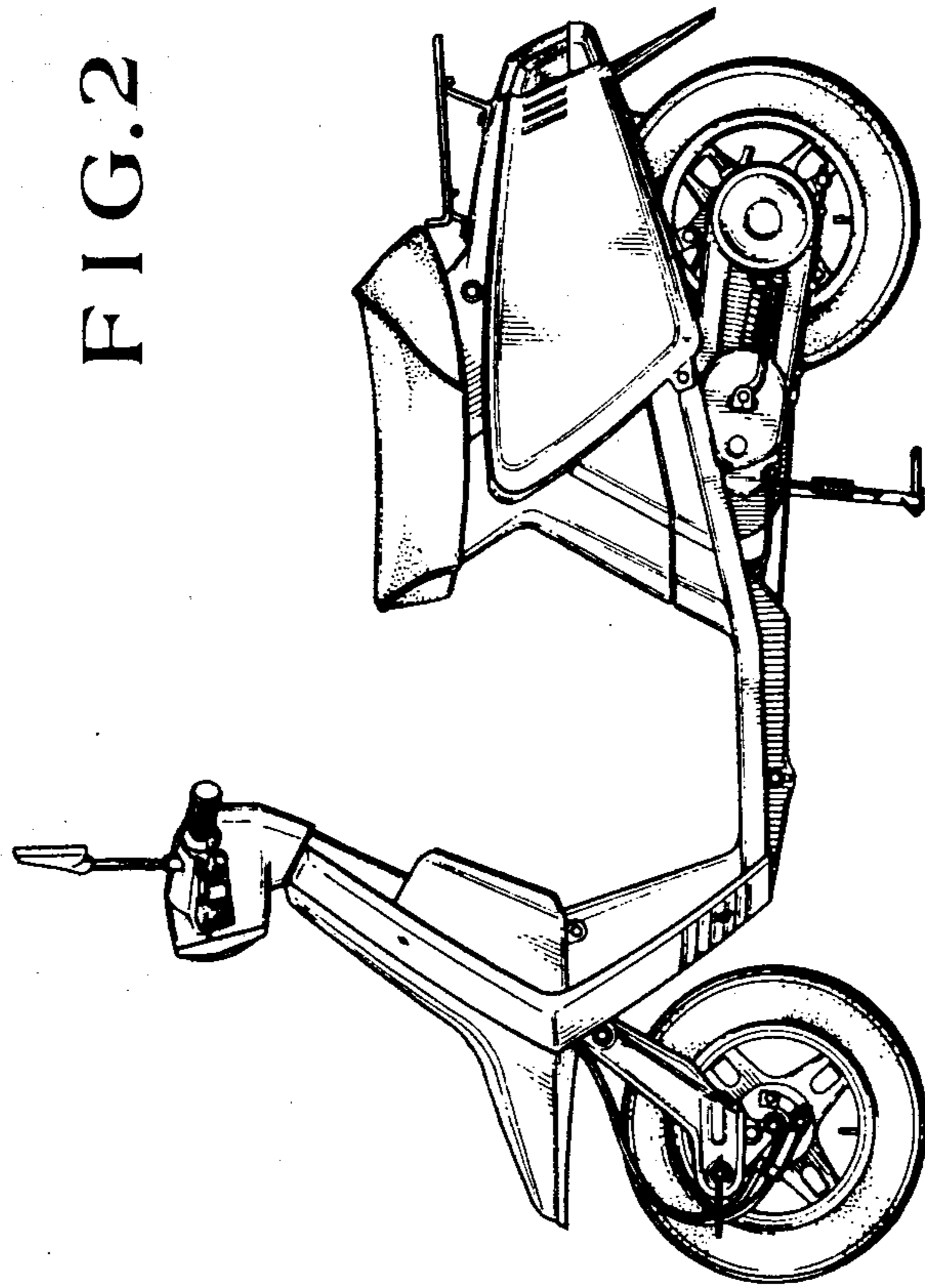

FIG.2



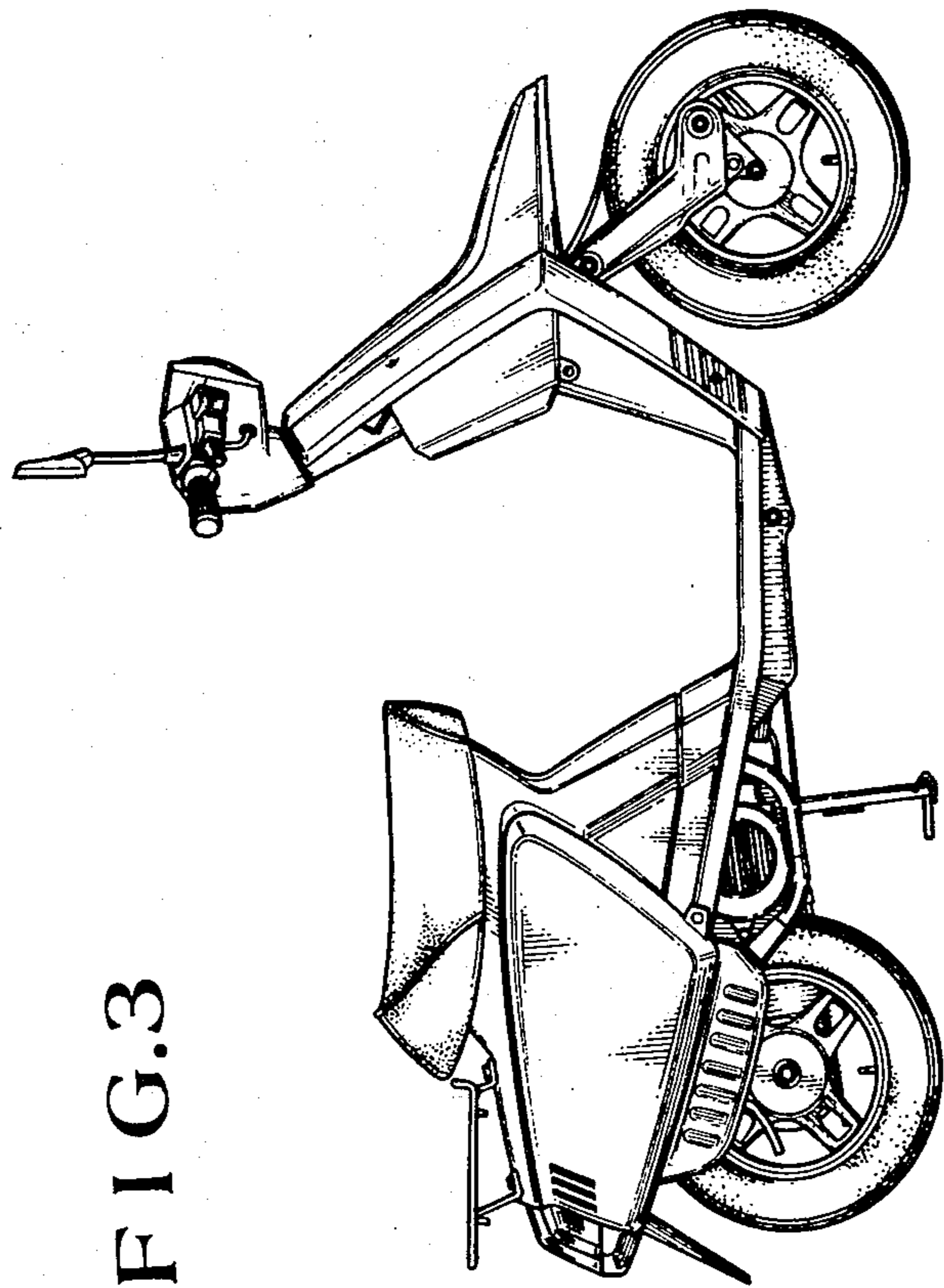

FIG.3

FIG.4

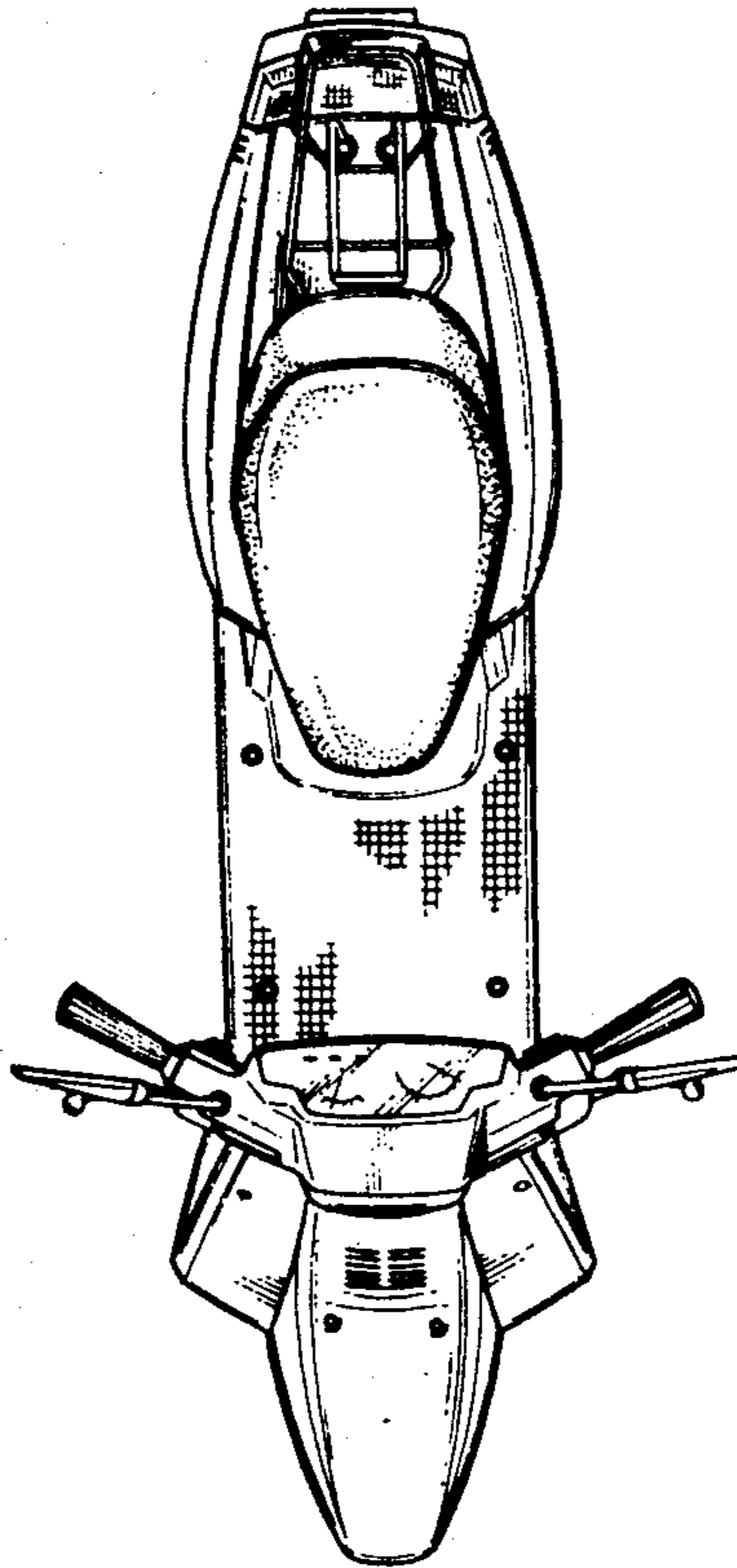

FIG.6

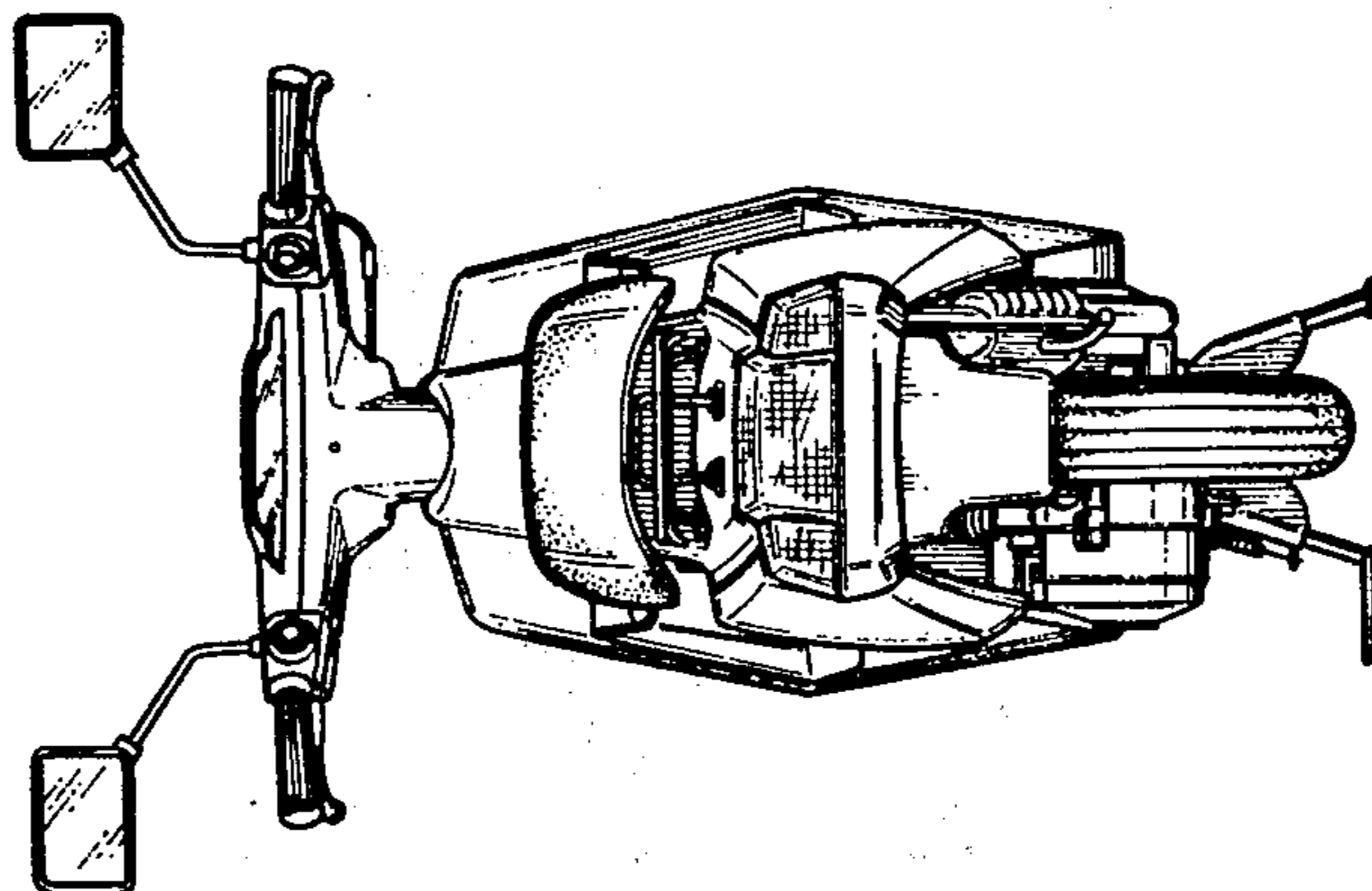

FIG.5

