

[54] MOTORCYCLE

[75] Inventor: Hidehiko Nagashima, Tokyo, Japan

[73] Assignee: Yamaha Hatsudoki Kabushiki Kaisha, Japan

[\*\*] Term: 14 Years

[21] Appl. No.: 352,210

[22] Filed: Feb. 25, 1982

[30] Foreign Application Priority Data

Sep. 1, 1981 [JP] Japan ..... 56-38715

[52] U.S. Cl. .... D12/110

[58] Field of Search ..... D12/110; 180/219

[56] References Cited

U.S. PATENT DOCUMENTS

D. 248,387 7/1978 Kurishima et al. .... D12/110

OTHER PUBLICATIONS

Cycle World, 3/81, p. 145, Motorcycle, bottom of page.

Cycle World, 4/81, p. 138, Motorcycle top of page.

Primary Examiner—James M. Gandy

Attorney, Agent, or Firm—Ostrolenk, Faber, Gerb & Soffen

[57] CLAIM

The ornamental design for a motorcycle, as shown.

DESCRIPTION

FIG. 1 is a perspective view of a motorcycle showing my new design;

FIG. 2 is a right-side elevational view thereof;

FIG. 3 is a left-side elevational view thereof;

FIG. 4 is a top plan view thereof;

FIG. 5 is a front elevational view thereof; and

FIG. 6 is a back elevational view thereof.

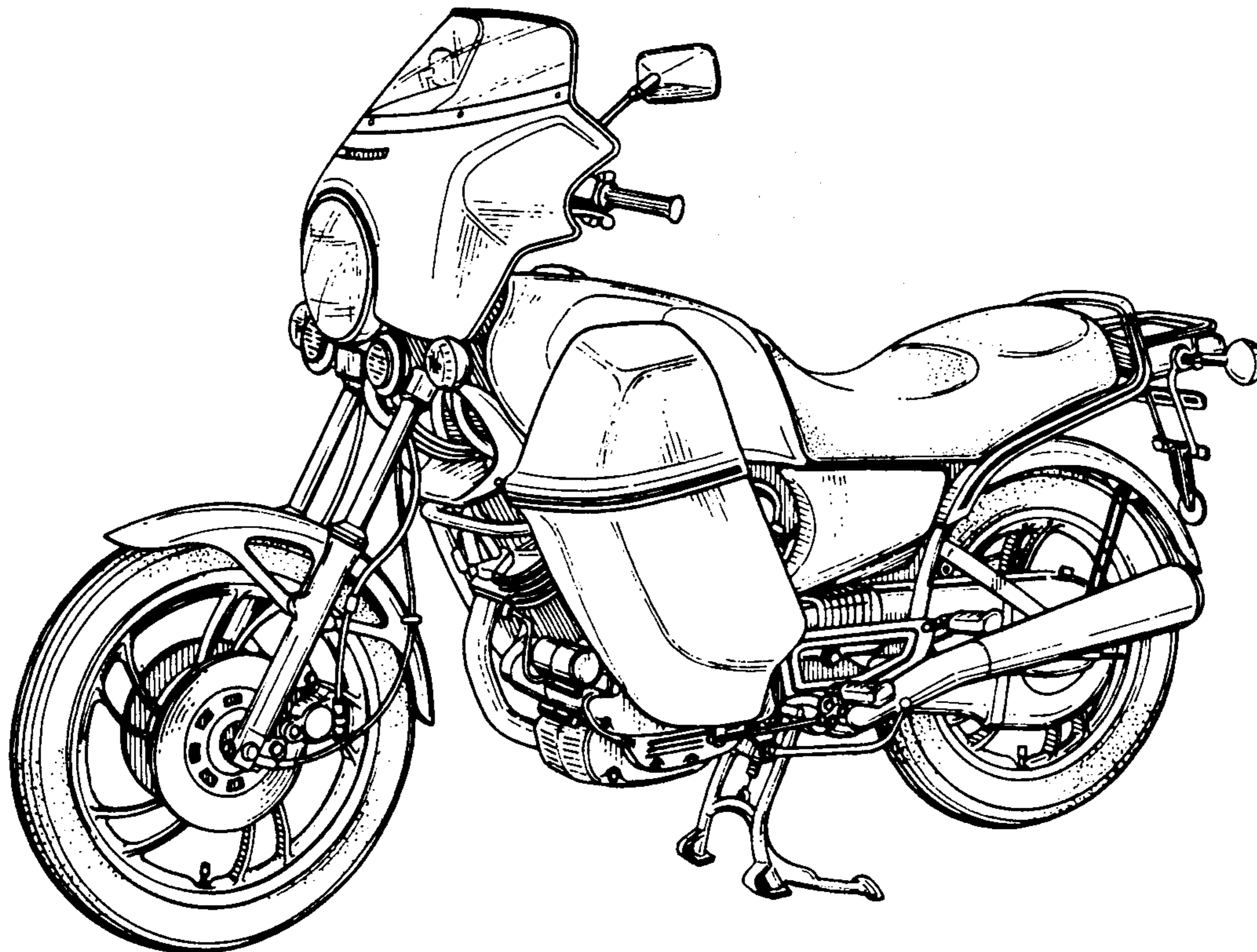

FIG. 1

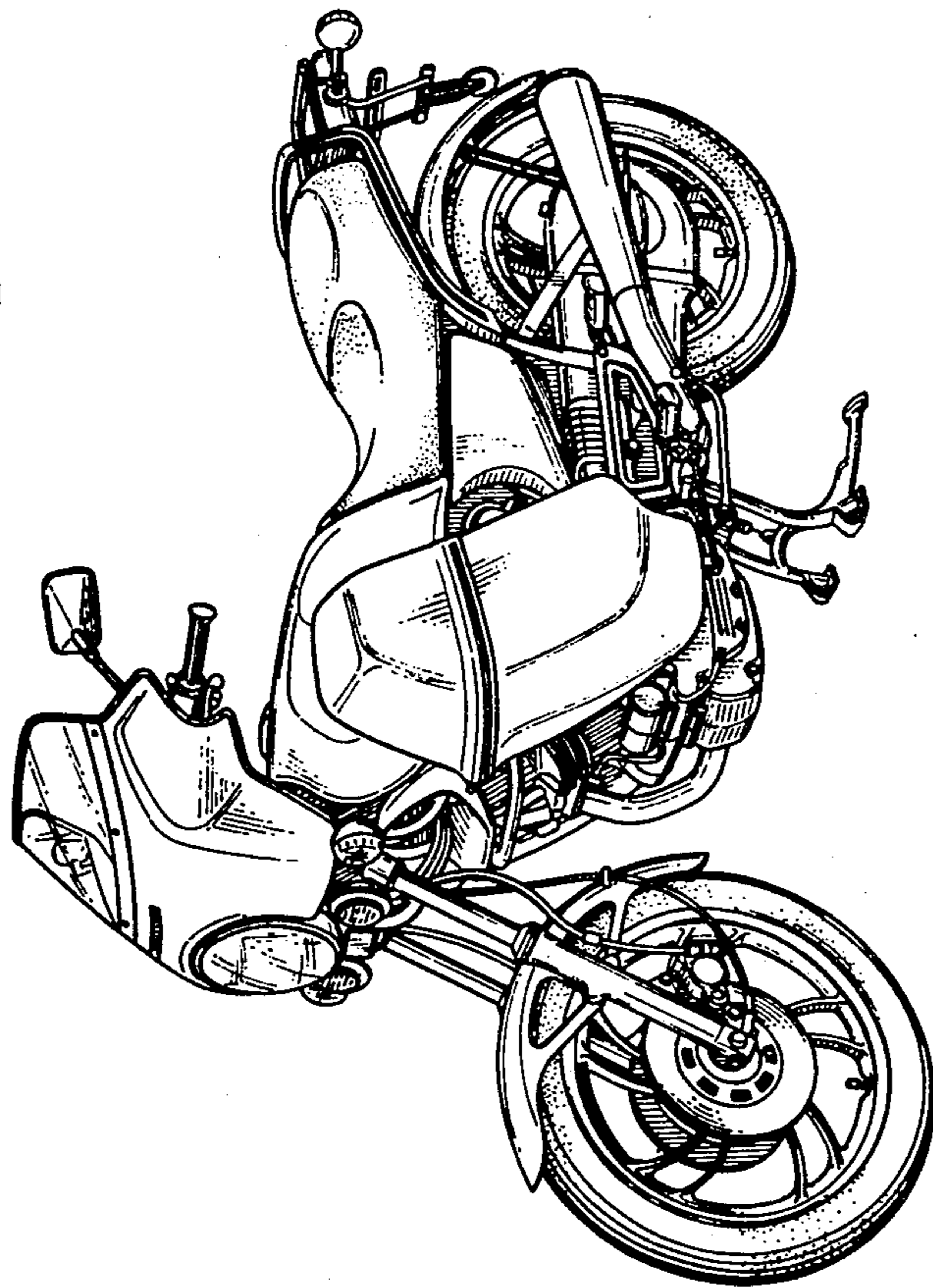
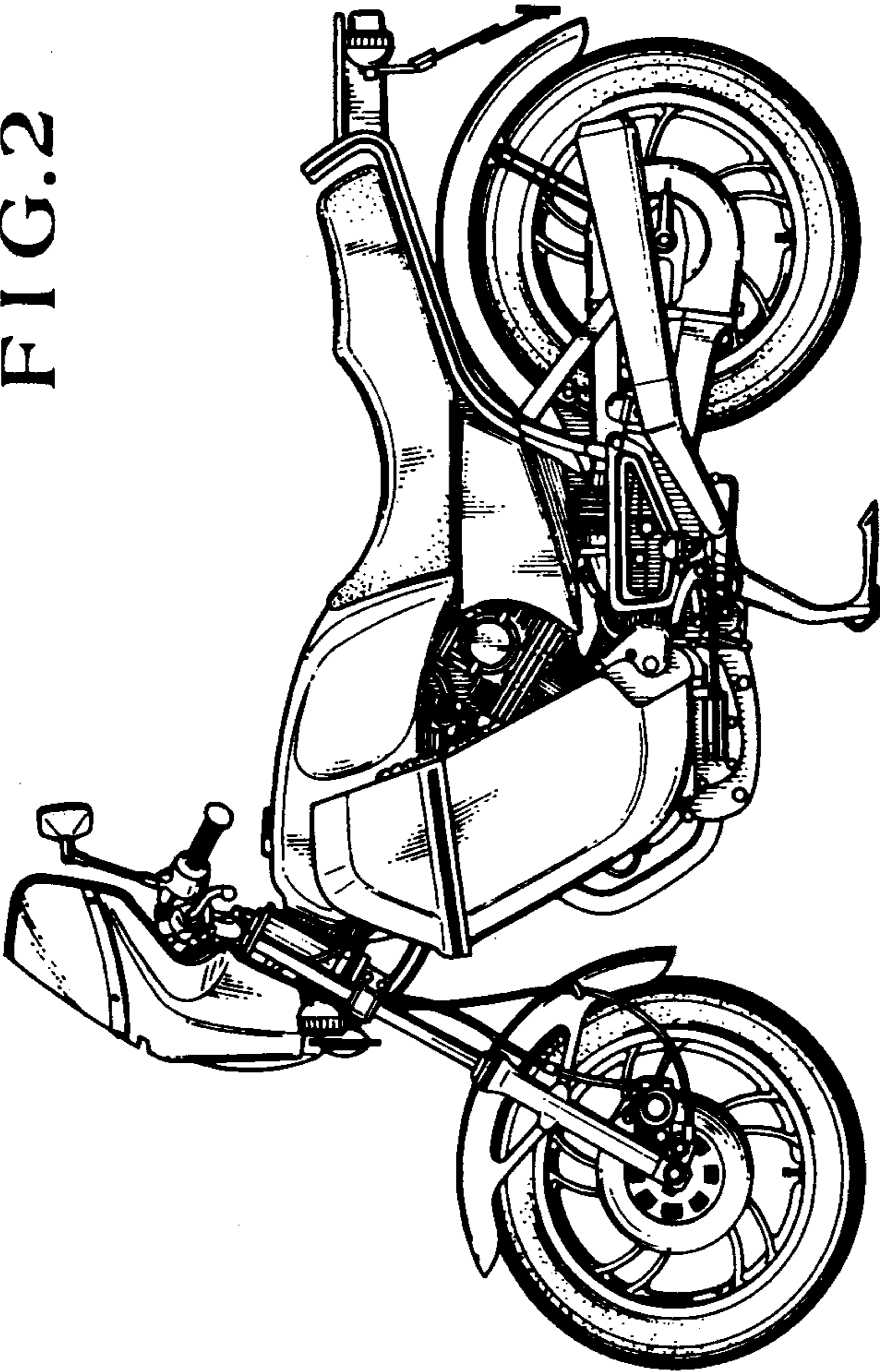

FIG. 2



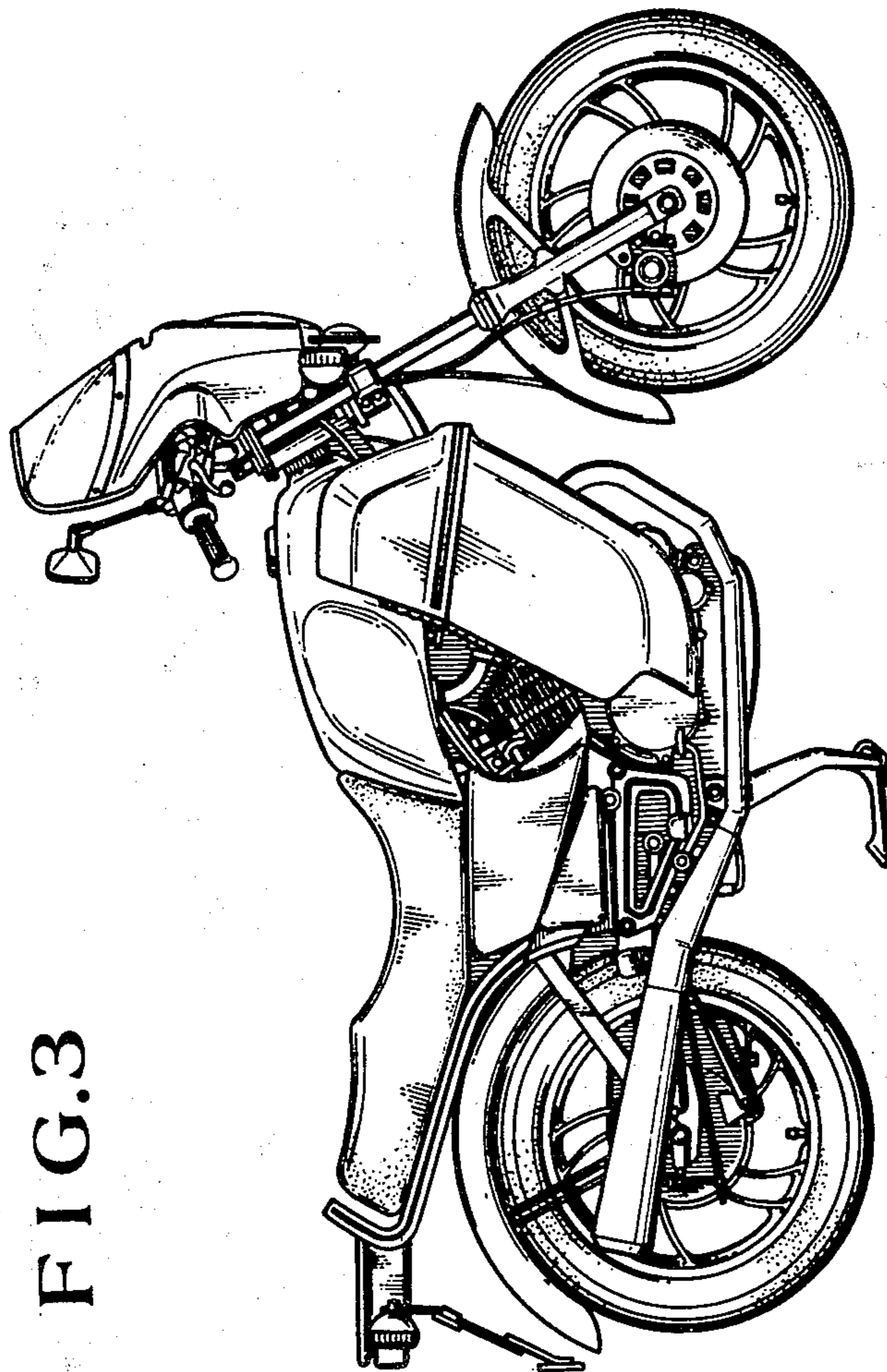

FIG. 3

FIG.4

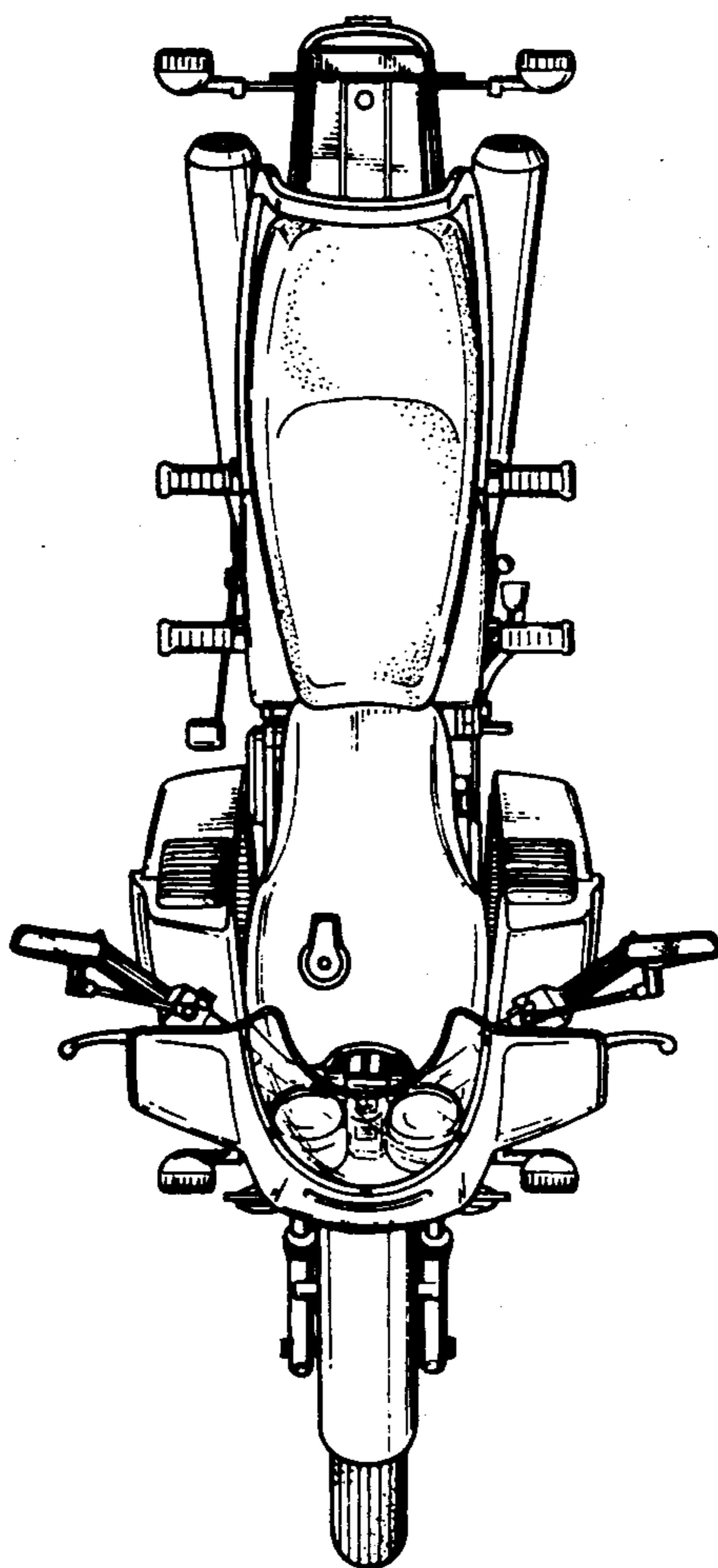

FIG.6

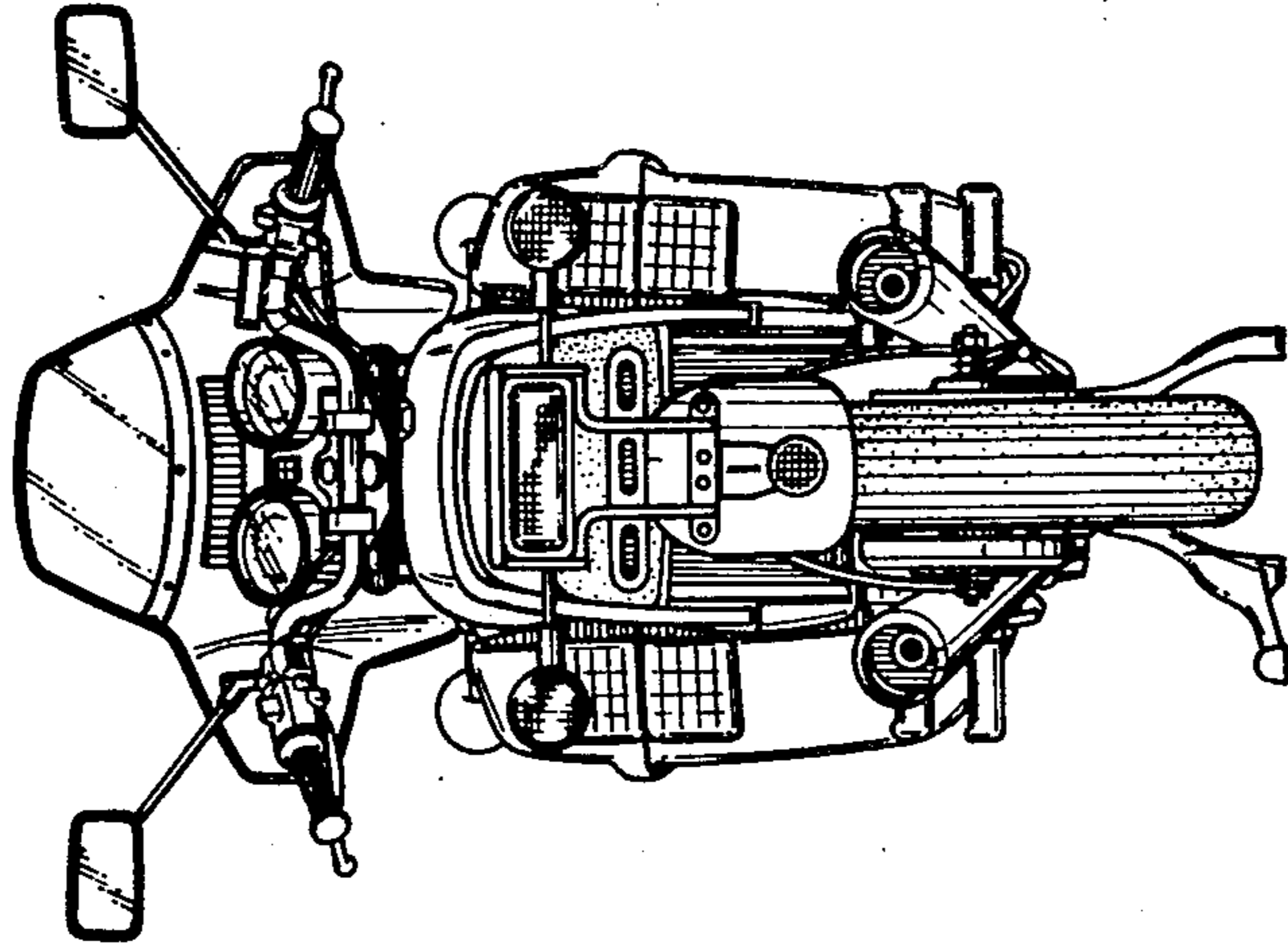

FIG.5

