

[54] AUTOMOBILE

[75] Inventors: **Claus Luthe**, Munich; **Manfred Rennen**, Ingolstadt; **Hans Braun**, Lohhof, all of Fed. Rep. of Germany

[73] Assignee: **Bayerische Motoren Werke Aktiengesellschaft**, Munich, Fed. Rep. of Germany

[**] Term: **14 Years**

[21] Appl. No.: **247,909**

[22] Filed: **Mar. 26, 1981**

[30] **Foreign Application Priority Data**

Sep. 30, 1980 [DE] Fed. Rep. of Germany ... MR 12 272
[52] U.S. Cl. **D12/92**
[58] Field of Search D12/92; 296/185

[56] **References Cited**
PUBLICATIONS

Motor Trend, 9/79, p. 74, BMW 528i.
Primary Examiner—James M. Gandy
Attorney, Agent, or Firm—Craig & Burns

[57] **CLAIM**

The ornamental design for an automobile, substantially as shown and described.

DESCRIPTION

FIG. 1 is a left side elevational view of the automobile showing my new design;
FIG. 2 is a right side elevational view thereof;
FIG. 3 is a perspective view from the front and to the left side thereof;
FIG. 4 is a perspective view thereof from the rear and to the right side;
FIG. 5 is a front elevational view thereof;
FIG. 6 is a rear elevational view thereof; and
FIG. 7 is a top plan view thereof.

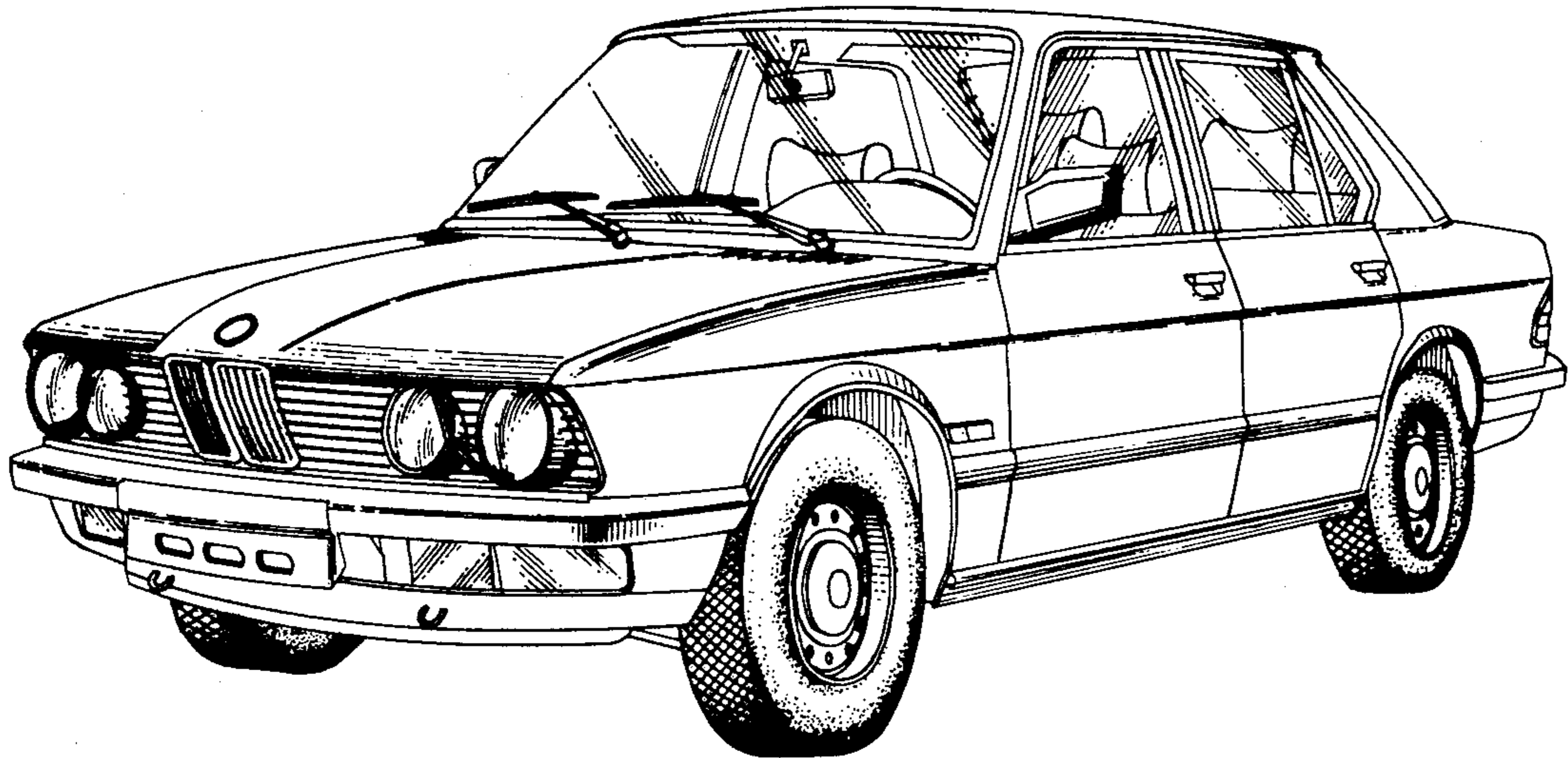

FIG. 1.

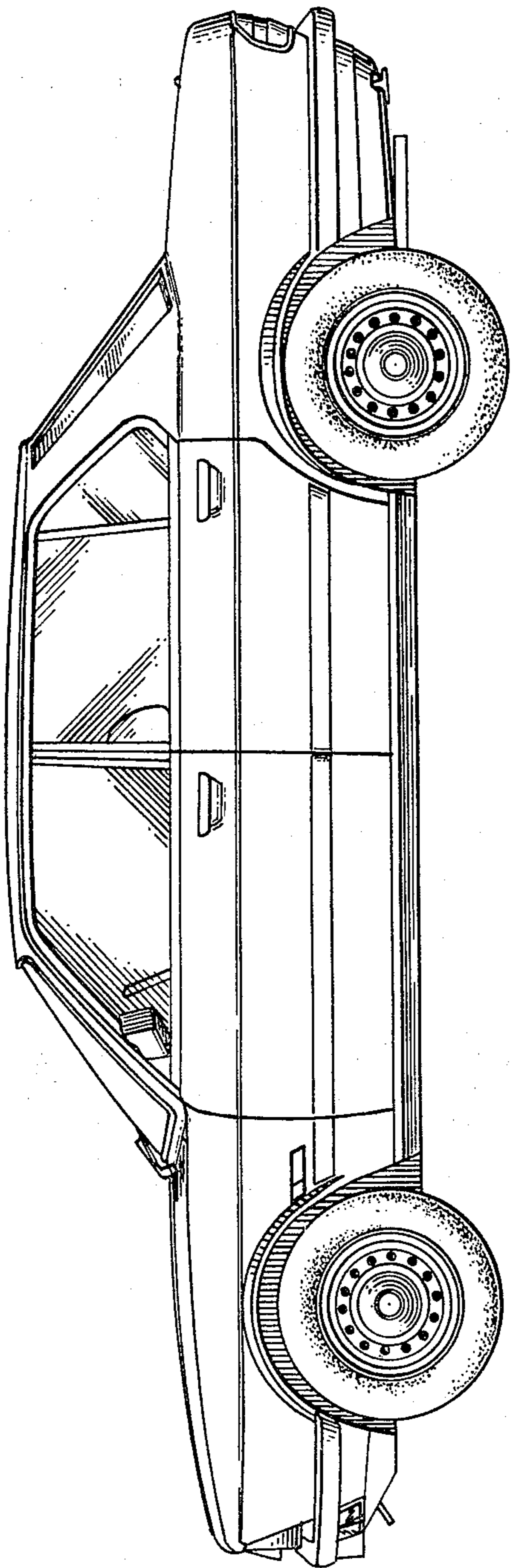

FIG. 2.

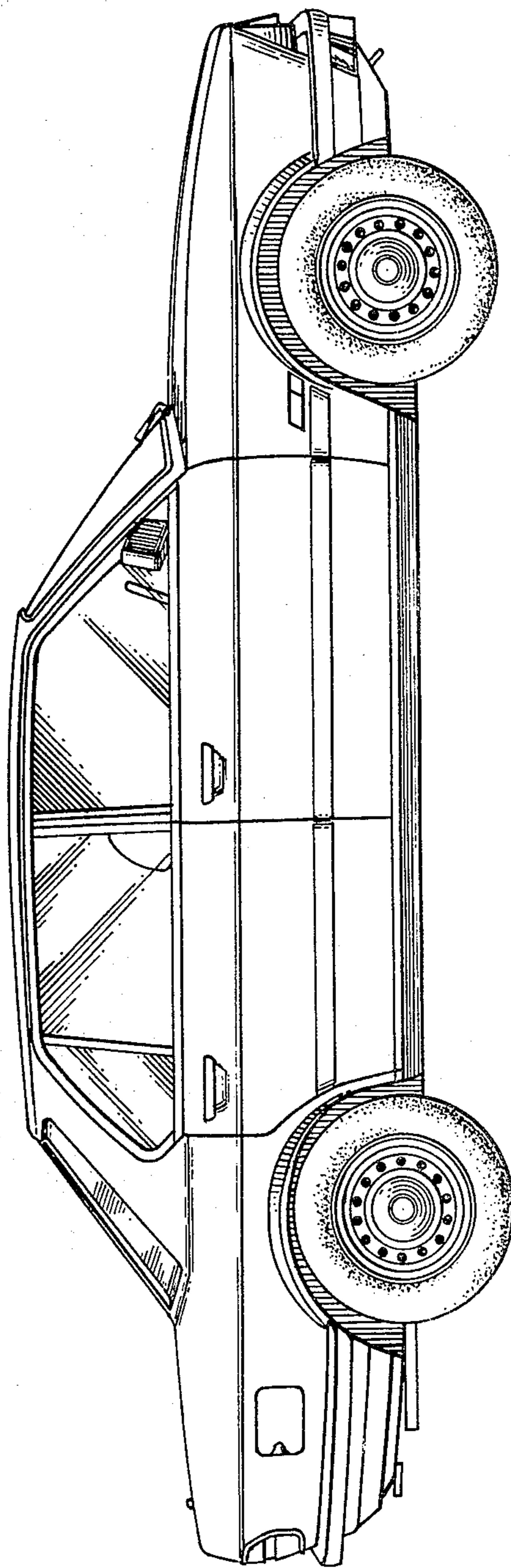

FIG. 3.

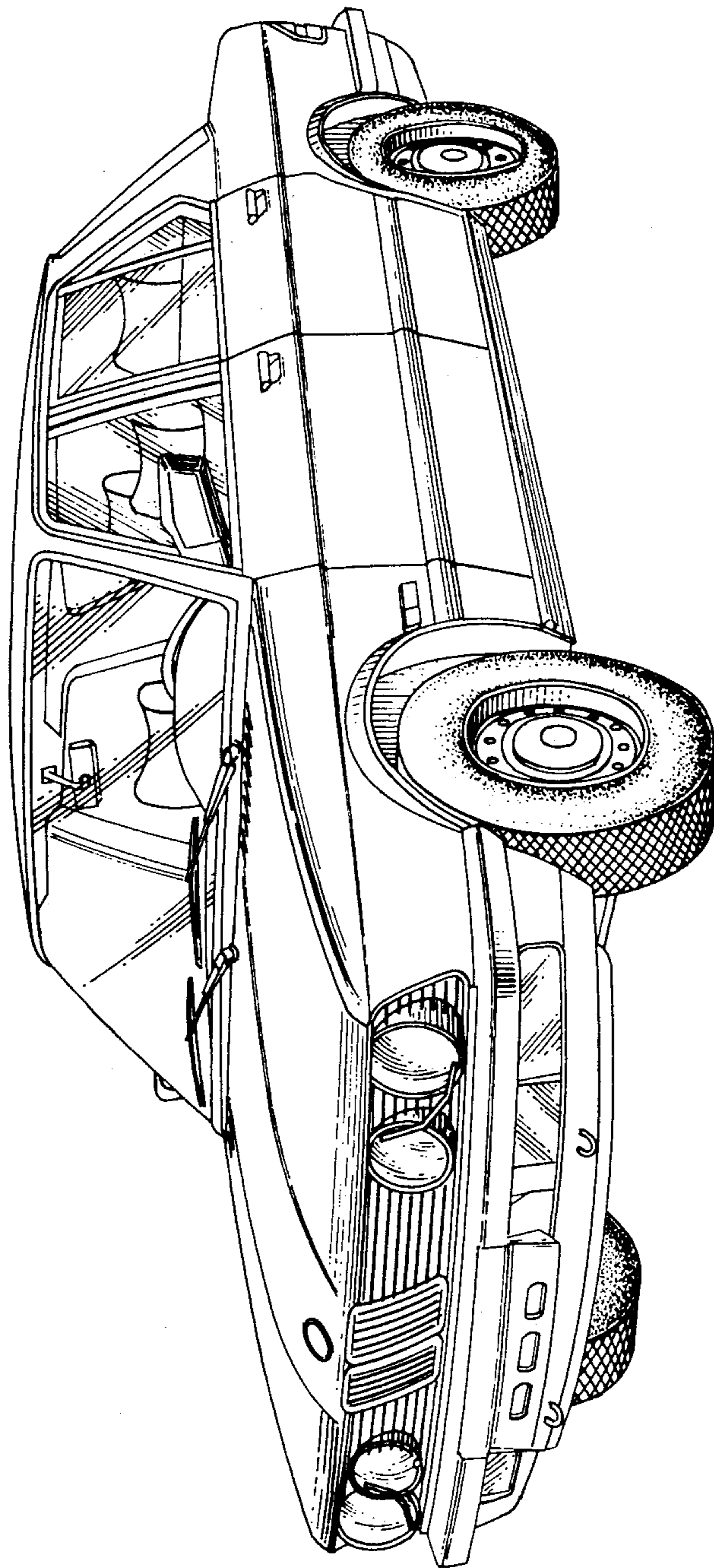

FIG. 4.

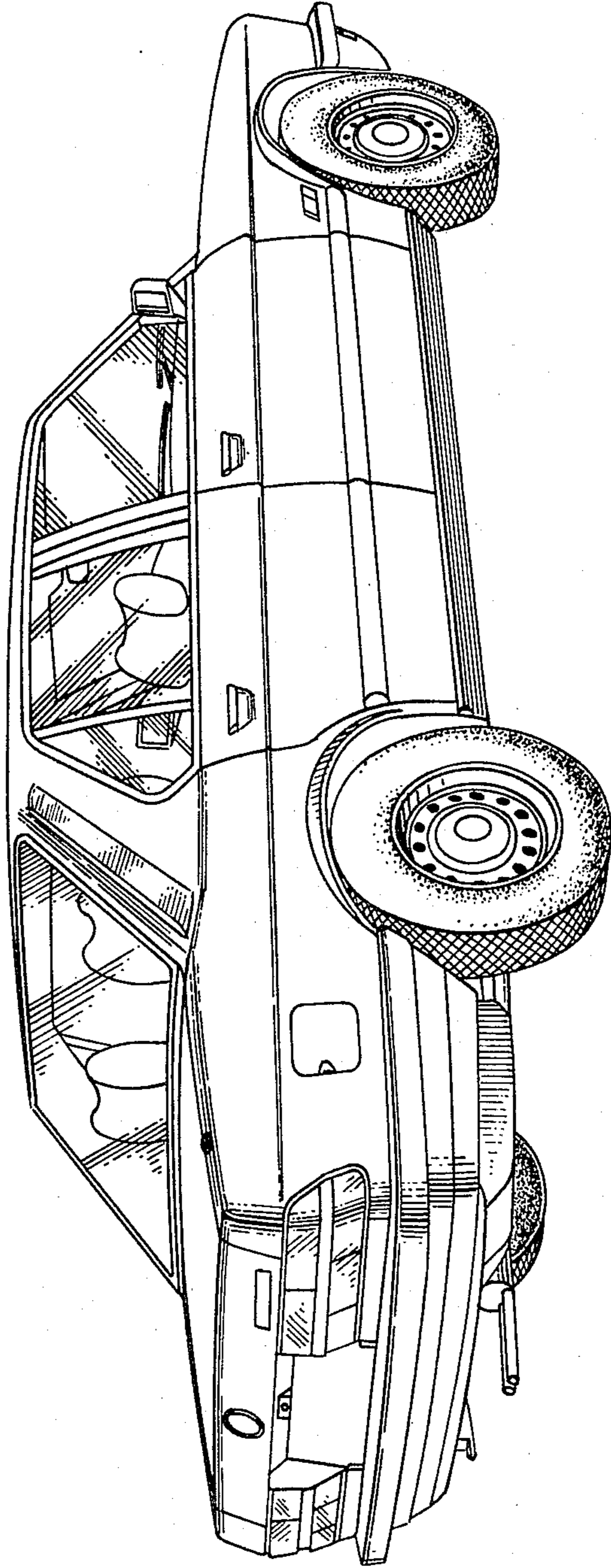

FIG. 5.

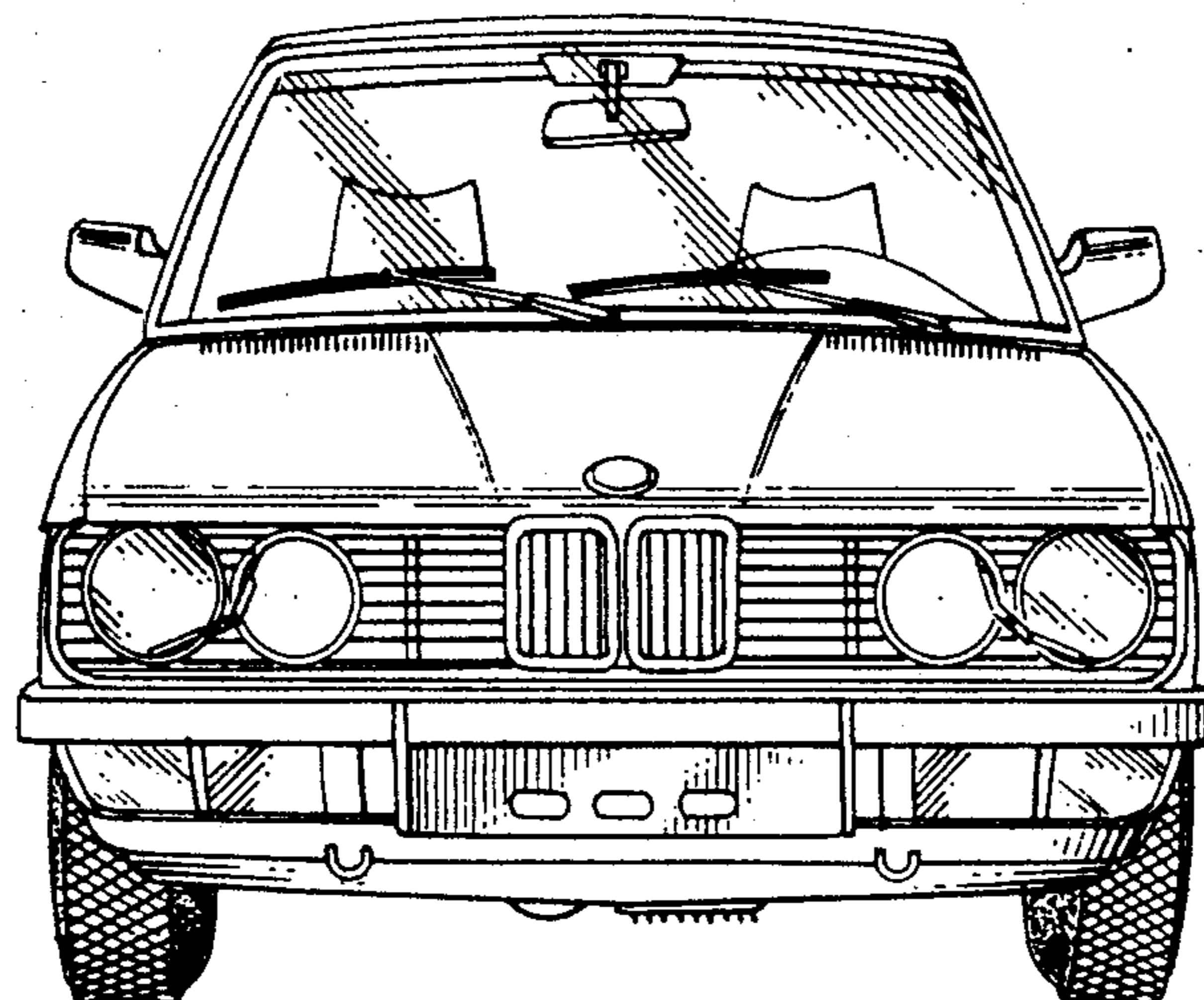

FIG. 6.

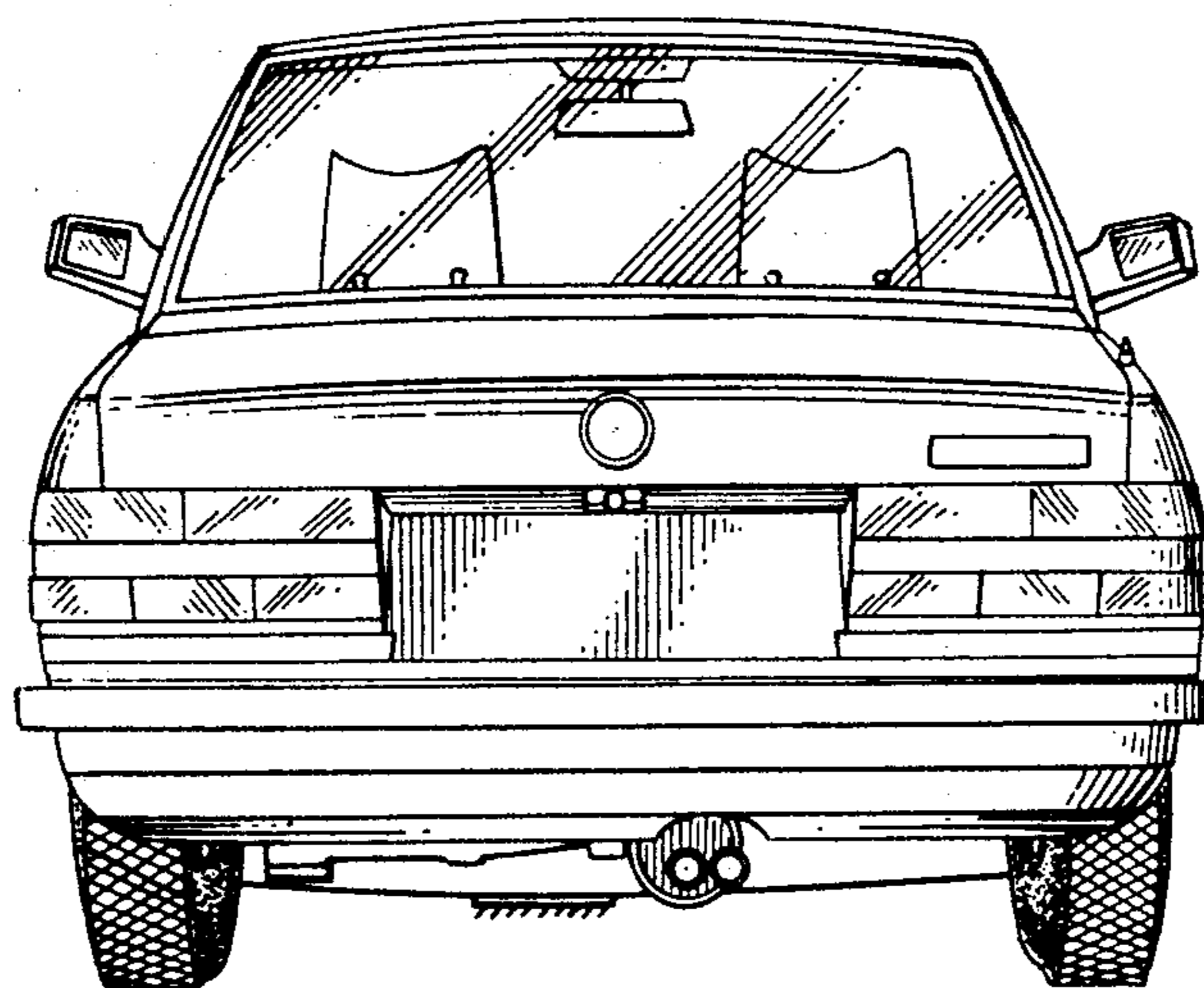

FIG. 7.

