

[54] BABY SEAT

[75] Inventors: Shinroku Nakao, Kanagawa; Yoshiyasu Ishii; Hiroaki Matsuda, both of Tokyo, all of Japan

[73] Assignee: Combi Co., Ltd., Tokyo, Japan

[**] Term: 14 Years

[21] Appl. No.: 298,394

[22] Filed: Sep. 1, 1981

[30] Foreign Application Priority Data

Mar. 2, 1981 [JP]	Japan	56-8365
Mar. 2, 1981 [JP]	Japan	56-8369
Mar. 2, 1981 [JP]	Japan	56-8370
[52] U.S. Cl.		D6/7; D6/9; D6/10
[58] Field of Search		D6/5, 7, 8, 9, 10; 297/250, 384, 389, 344, 355, 377

[56] References Cited

U.S. PATENT DOCUMENTS

D. 261,828	11/1981	Nakao et al.	D6/71
4,033,622	7/1977	Boudreau	D6/7 X

Primary Examiner—Bruce W. Dunkins
Attorney, Agent, or Firm—Sughrue, Mion, Zinn, Macpeak and Seas

[57] CLAIM

The ornamental design for a baby seat, as shown and described.

DESCRIPTION

FIG. 1 is a right side elevational view of a baby seat showing our new design;
 FIG. 2 is a top plan view thereof;
 FIG. 3 is a bottom plan view thereof;
 FIG. 4 is a front elevational view thereof;
 FIG. 5 is a rear elevational view thereof;
 FIG. 6 is a left side elevational view thereof;
 FIG. 7 is a front and right side perspective view thereof; and
 FIG. 8 is a similar perspective view to that of FIG. 7 with the legs in folded up position for vehicle use.

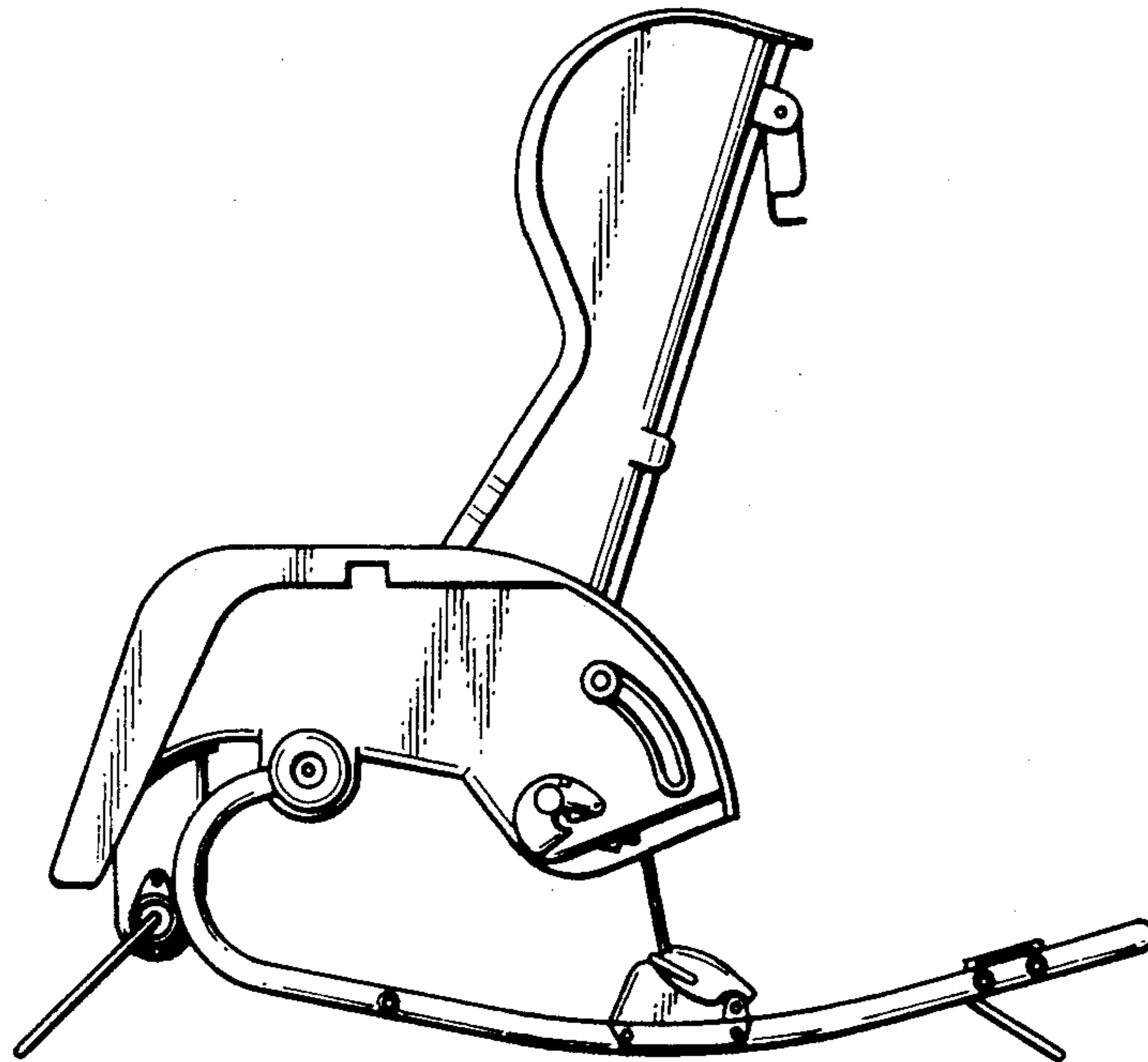

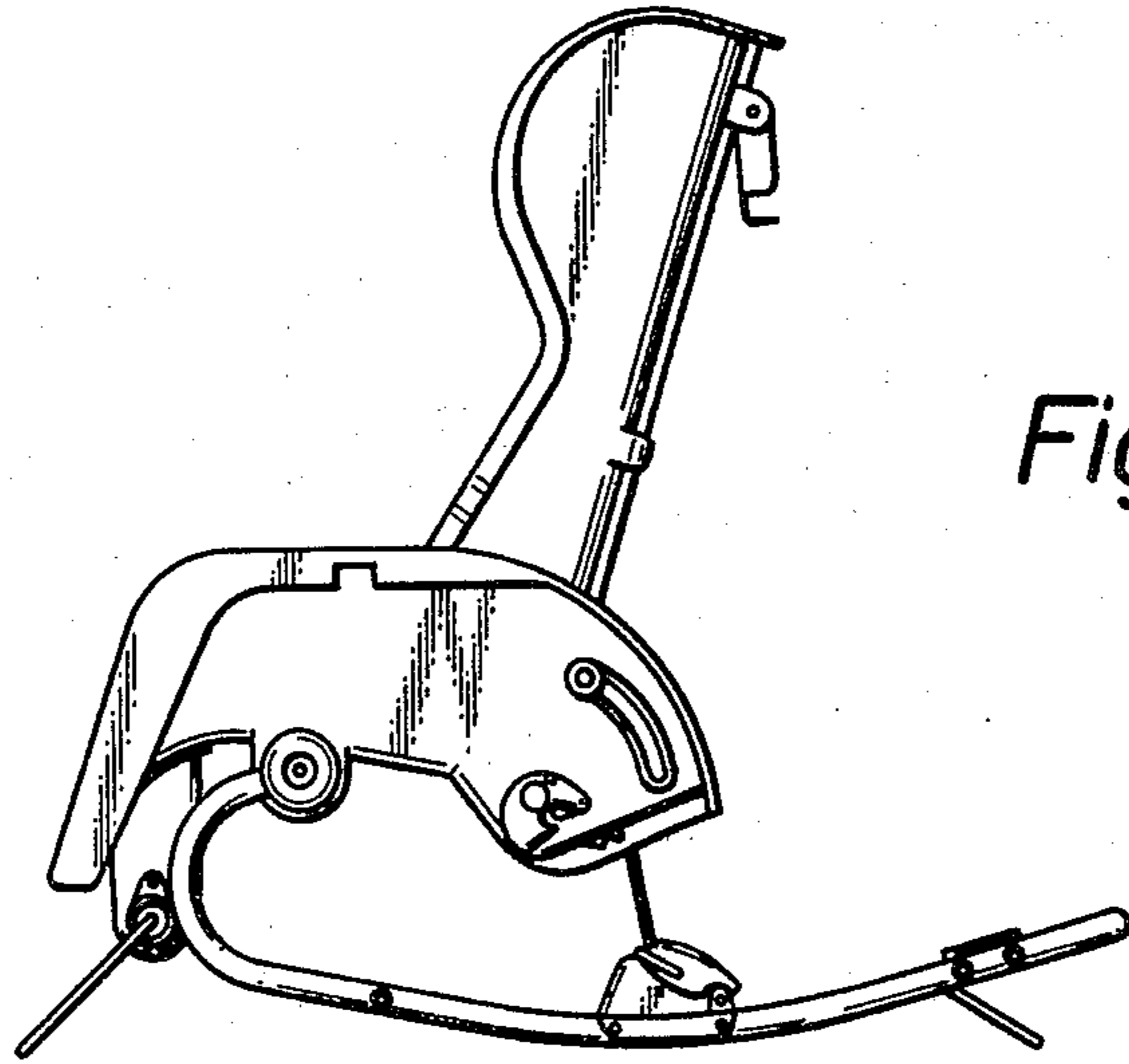

Fig. 1

Fig. 2

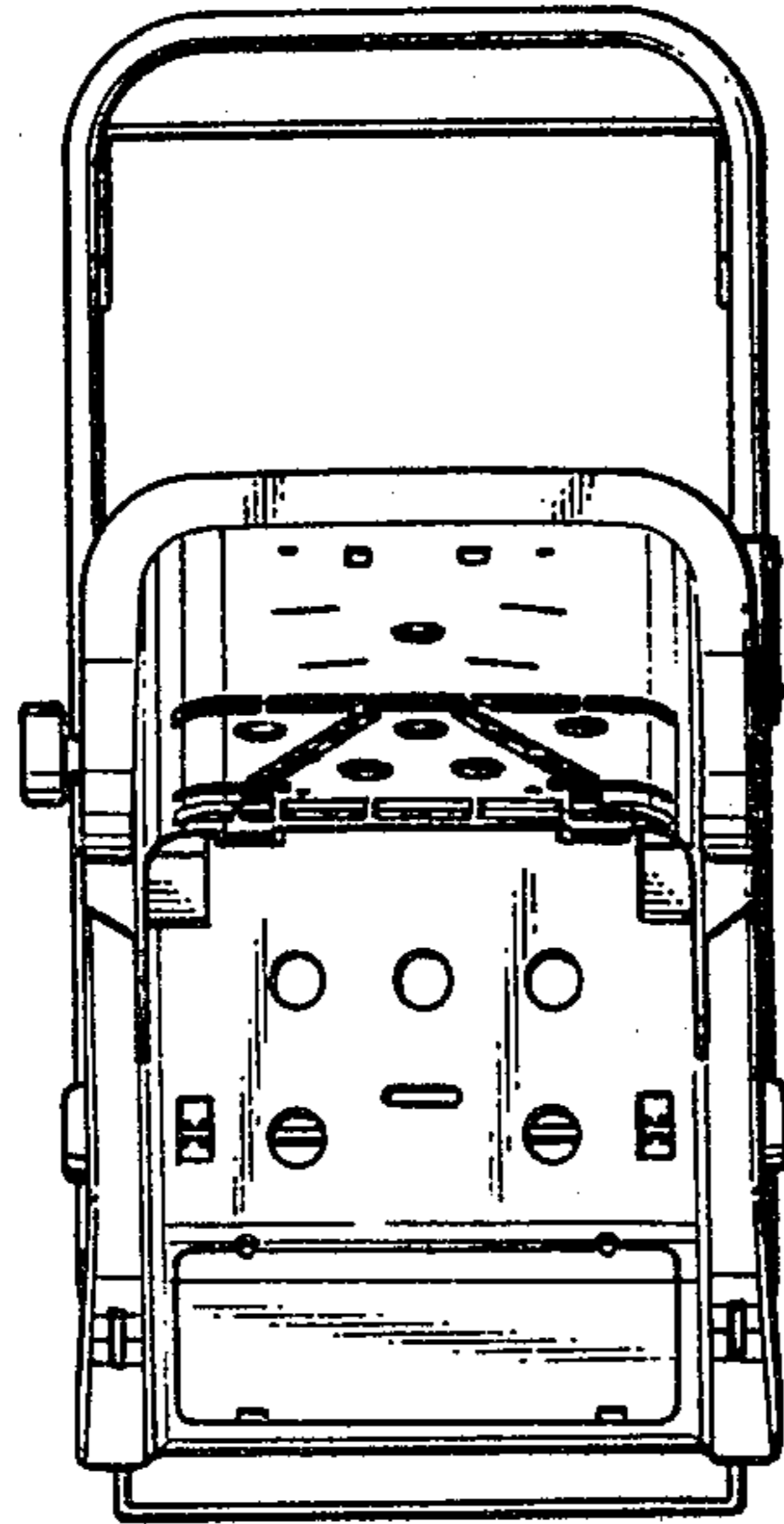

Fig. 3

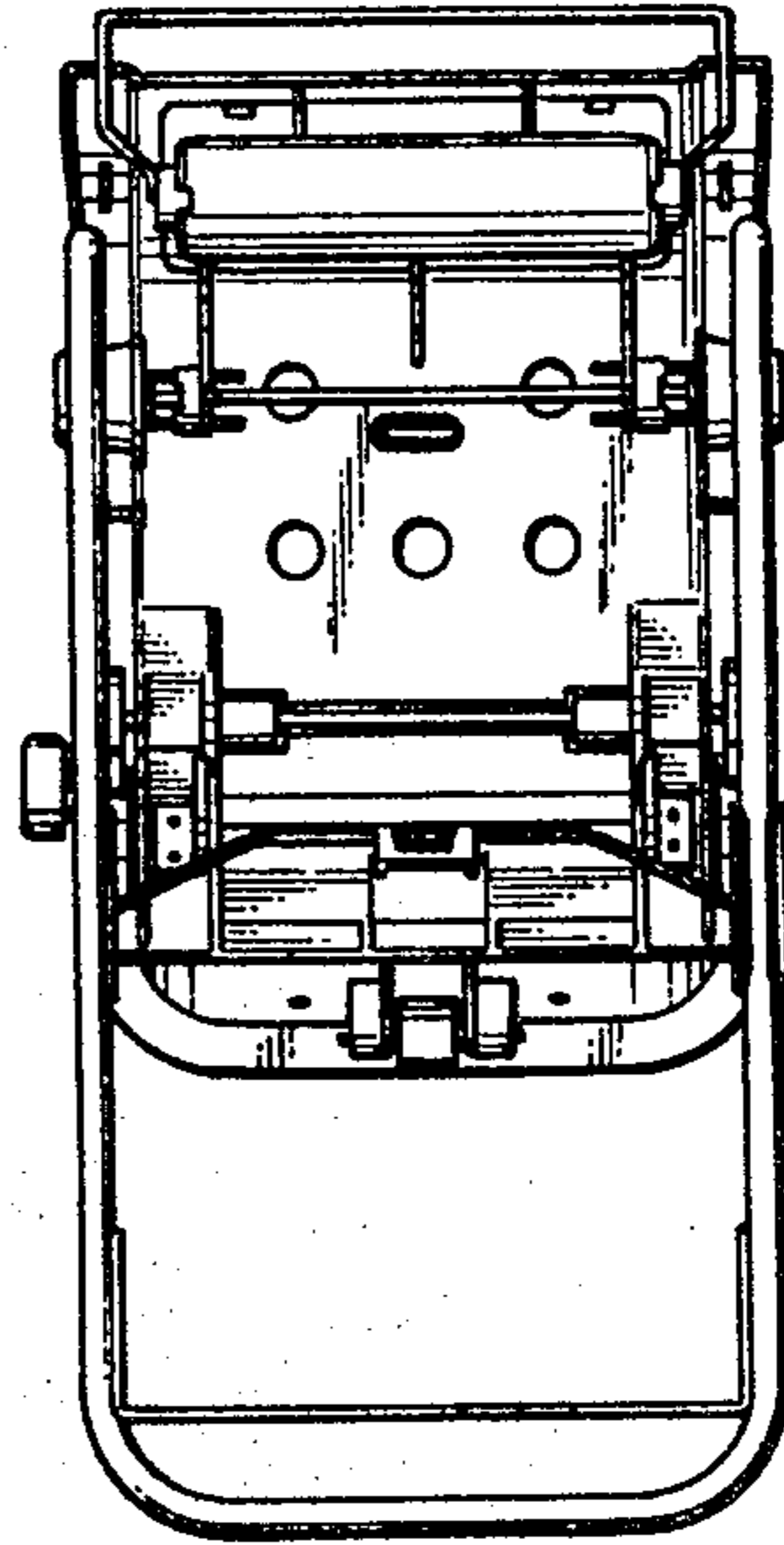

Fig. 4

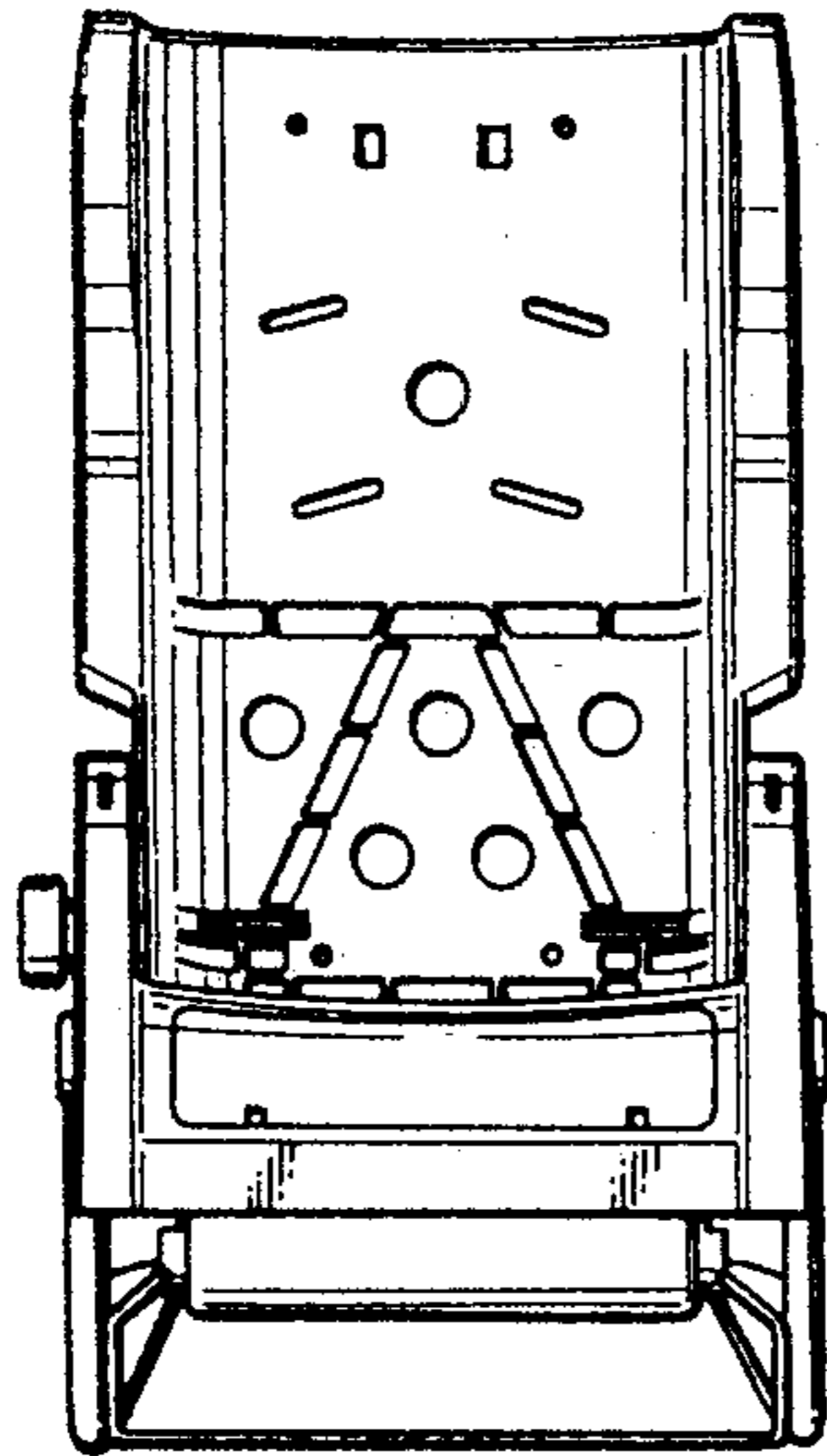

Fig. 5

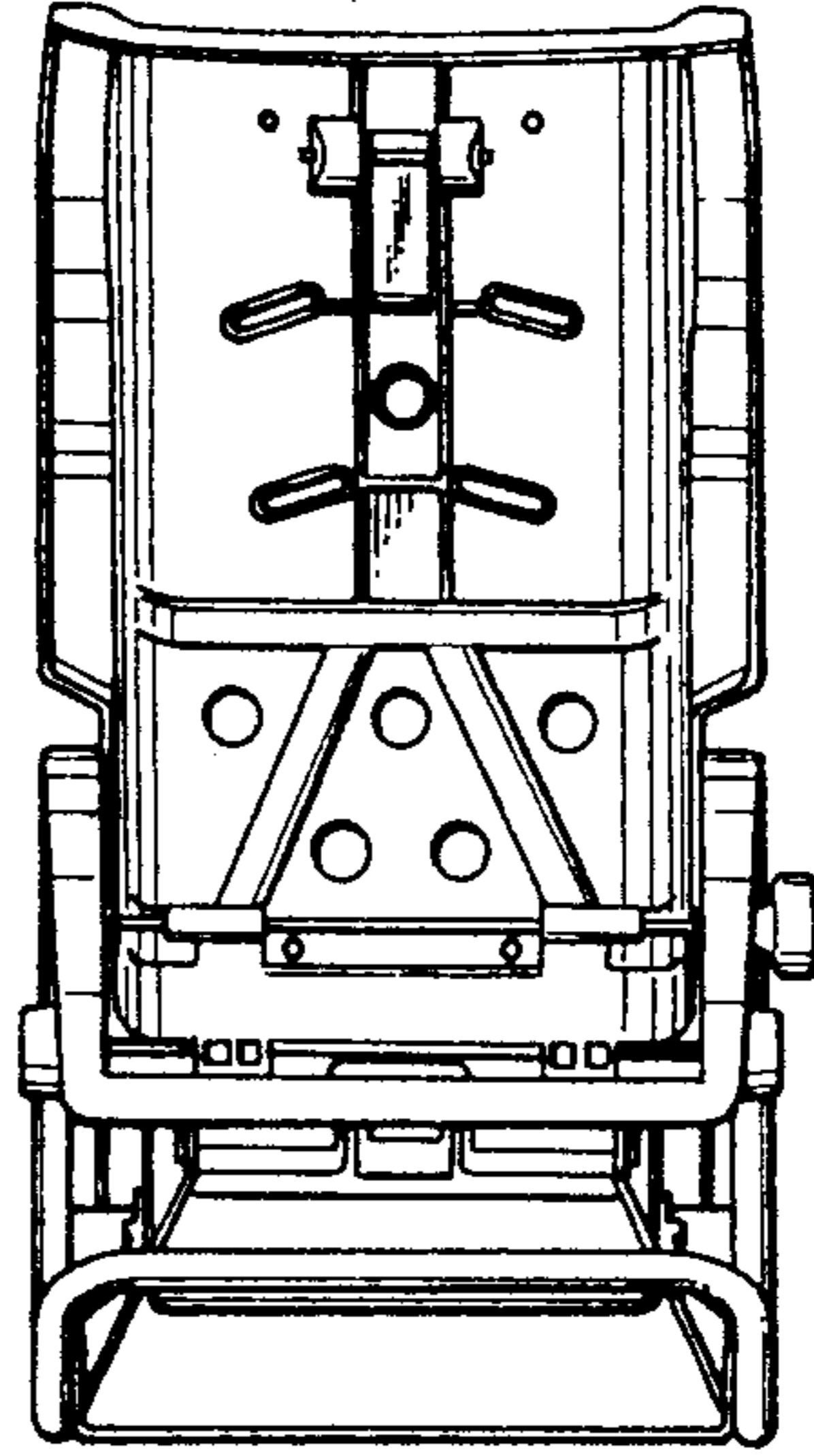

Fig. 6

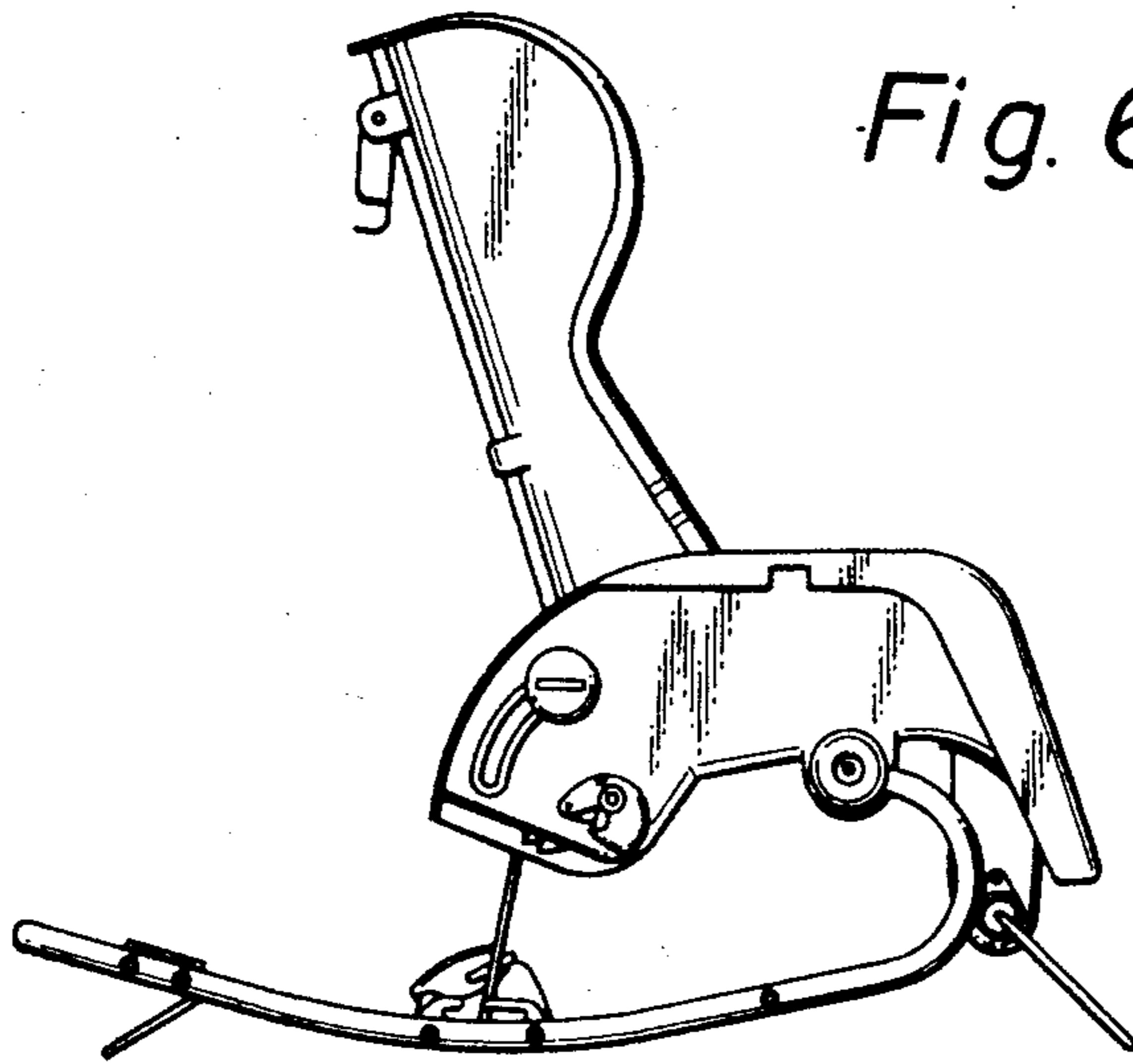

Fig. 7

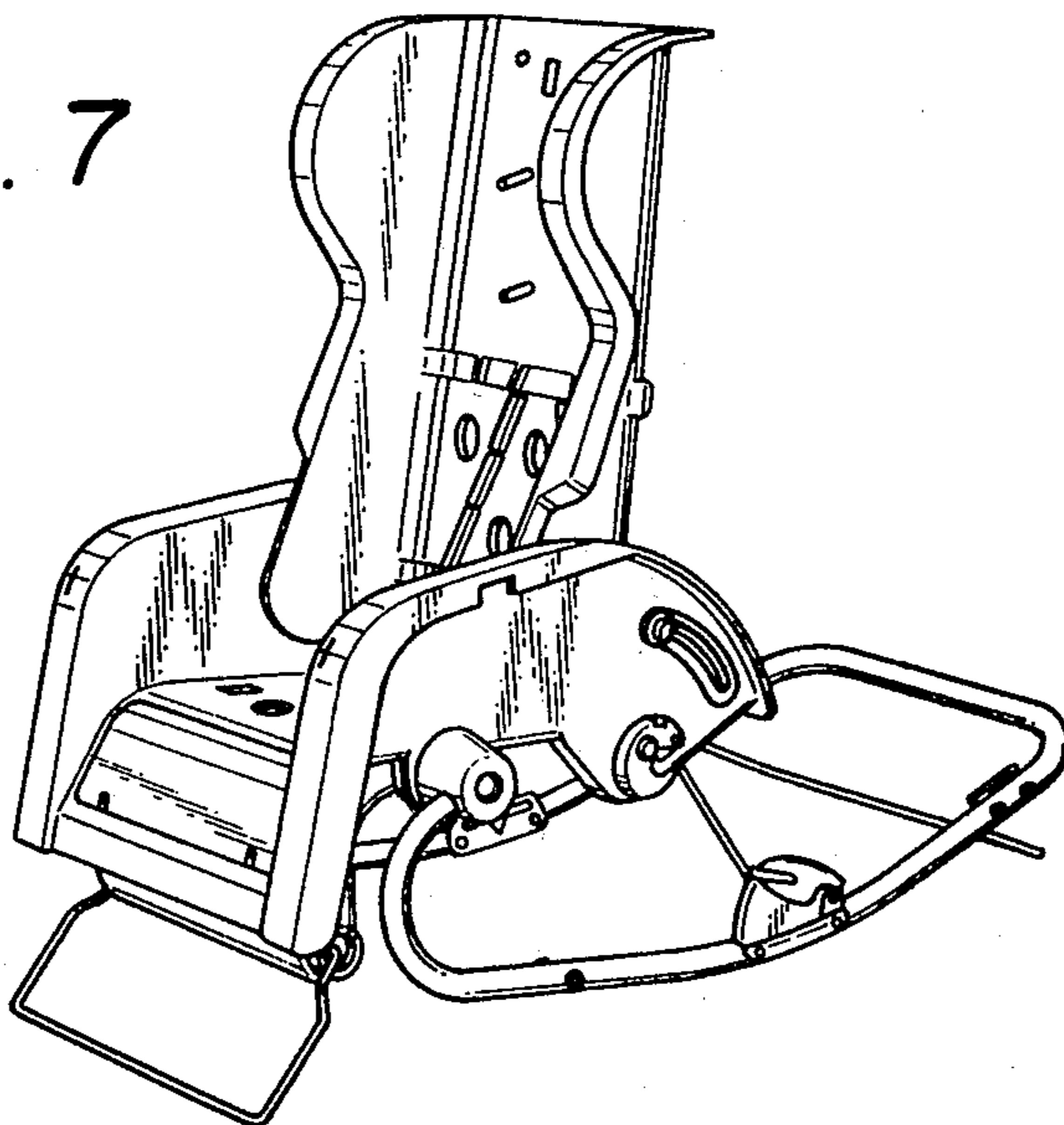

Fig. 8

