

[54] AIRPLANE

[75] Inventors: Ray Olason; Philip C. Whitener, both of Seattle, Wash.

[73] Assignee: The Boeing Company, Seattle, Wash.

[**] Term: 14 Years

[21] Appl. No.: 307,343

[22] Filed: Sep. 30, 1981

[52] U.S. Cl. D12/338

[58] Field of Search D12/319, 326-345; 244/15, 45 R, 55

[56] References Cited

U.S. PATENT DOCUMENTS

- D. 232,426 8/1974 Szlenkier D12/330
- D. 232,927 9/1974 Blattner et al. D12/341 X
- D. 234,079 1/1975 Whitener D12/331

- D. 258,648 3/1981 Martin et al. D12/337
- D. 259,411 6/1981 Miller et al. 12/341
- 3,854,679 12/1974 Smethers, Jr. D12/335 X

Primary Examiner—Catherine E. Kemper
Attorney, Agent, or Firm—H. Gus Hartmann; B. A. Donahue

[57] CLAIM

The ornamental design for an airplane, as shown and described.

DESCRIPTION

FIG. 1 is a side elevational view of an airplane depicting our new design;

FIG. 2 is a front elevational view;

FIG. 3 is a top plan view;

FIG. 4 is an upper front side perspective view;

FIG. 5 is an upper side perspective view; and

FIG. 6 is an upper rear side perspective view.

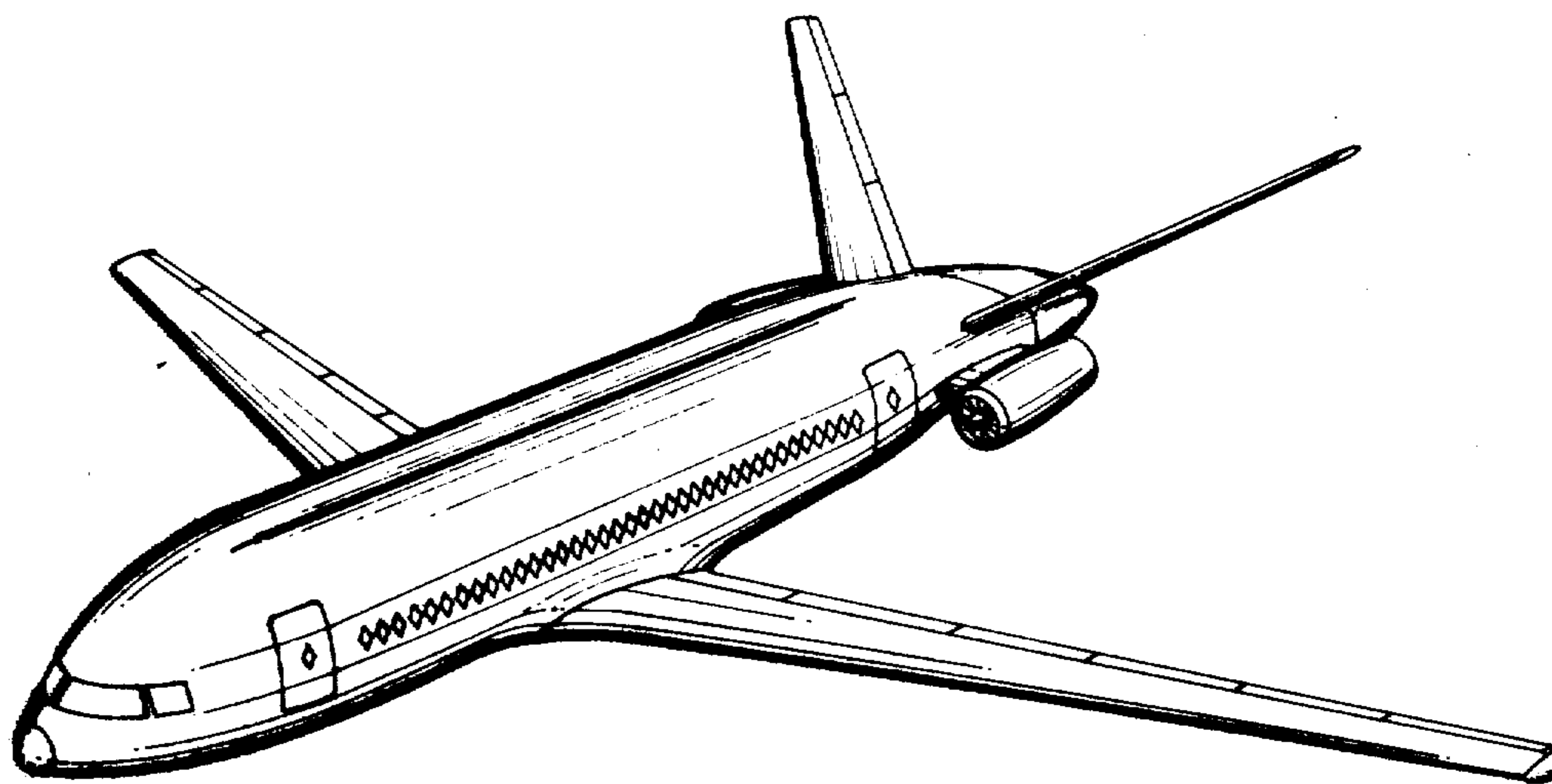

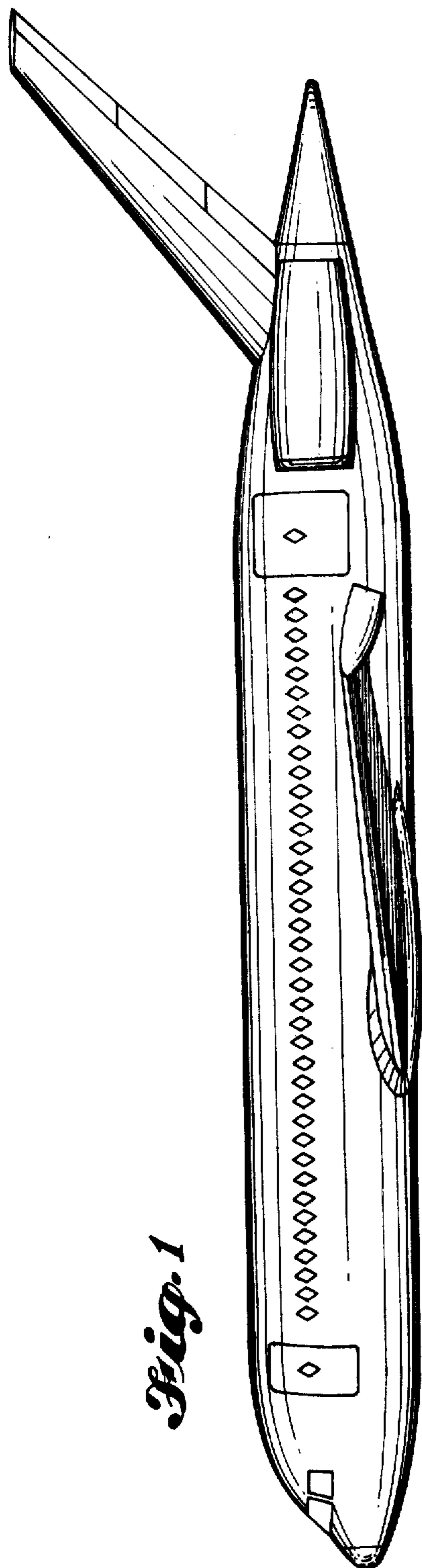

Fig. 1

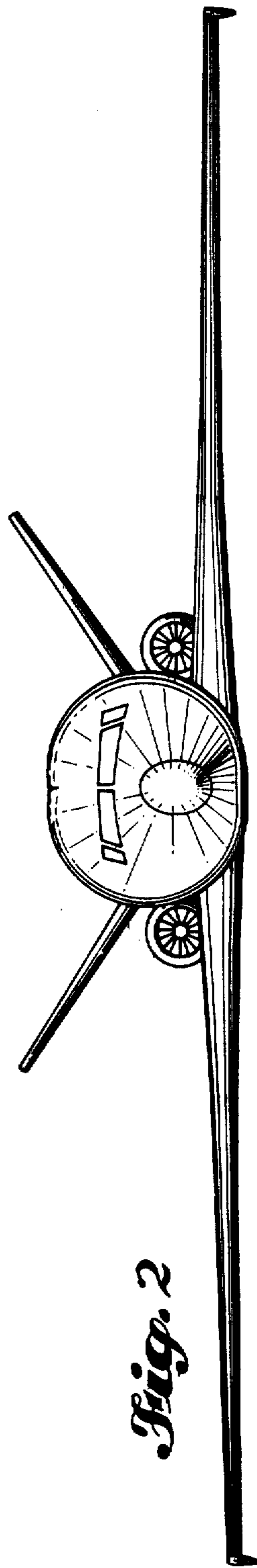
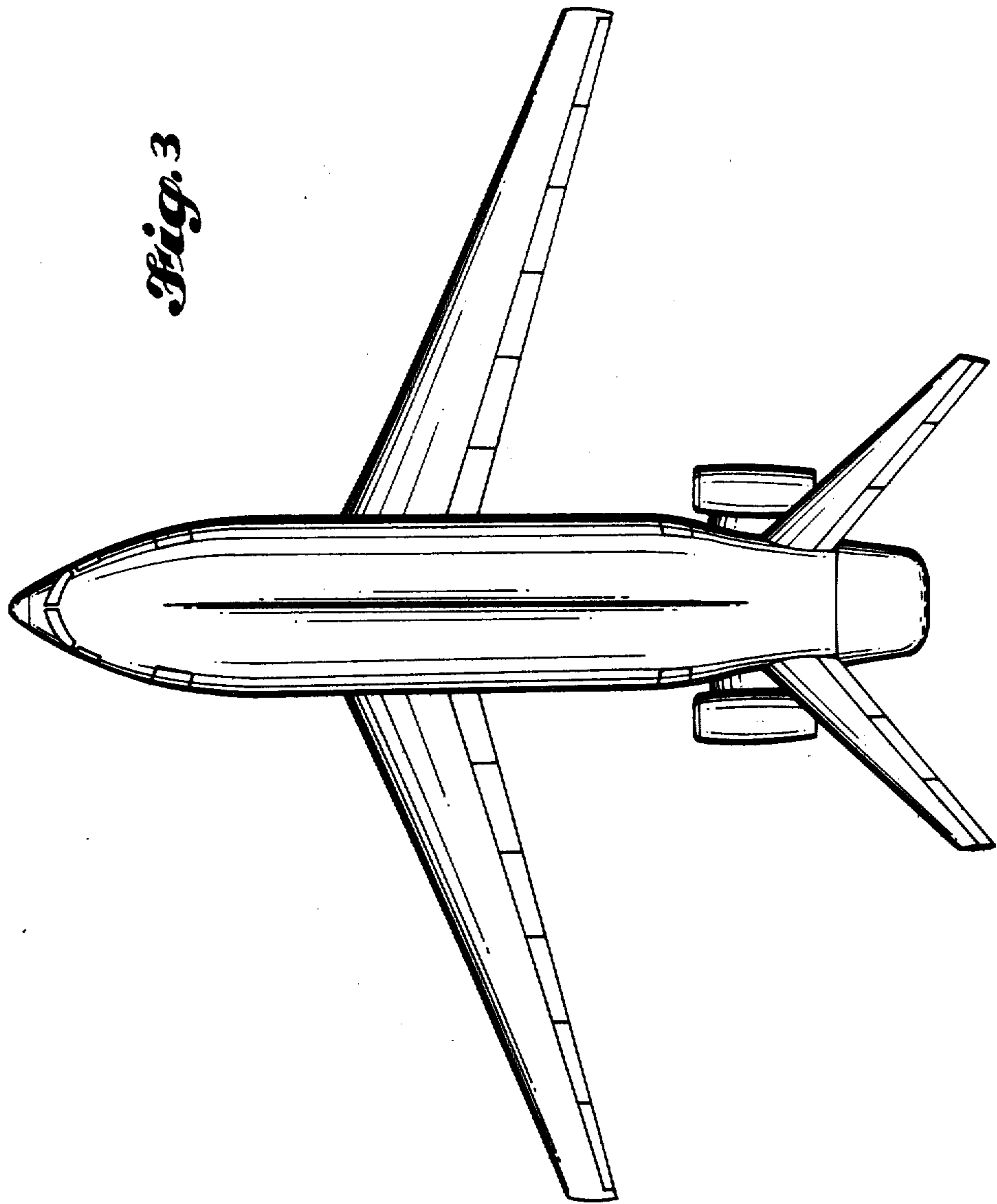

Fig. 2

Fig. 3



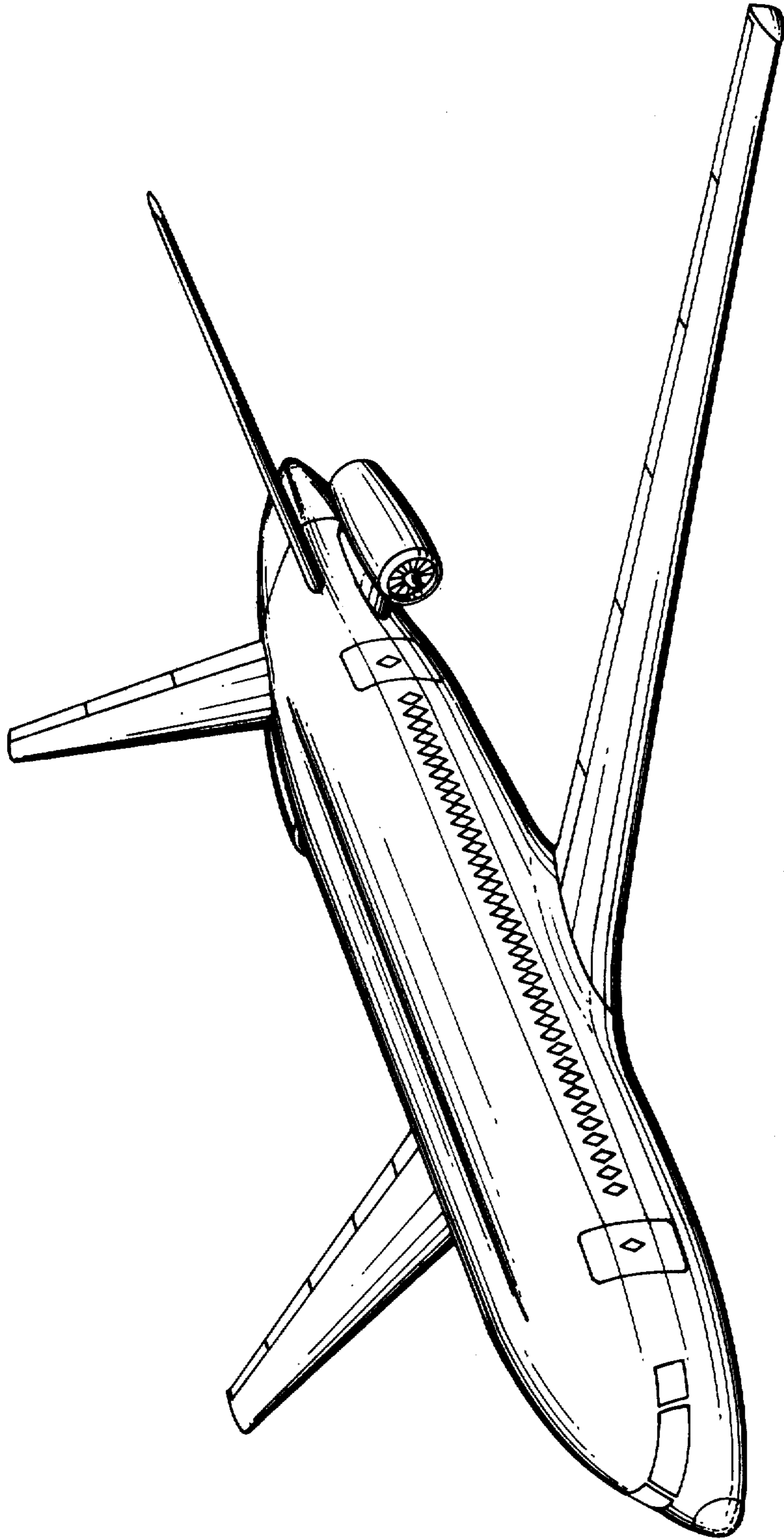

Fig. 4

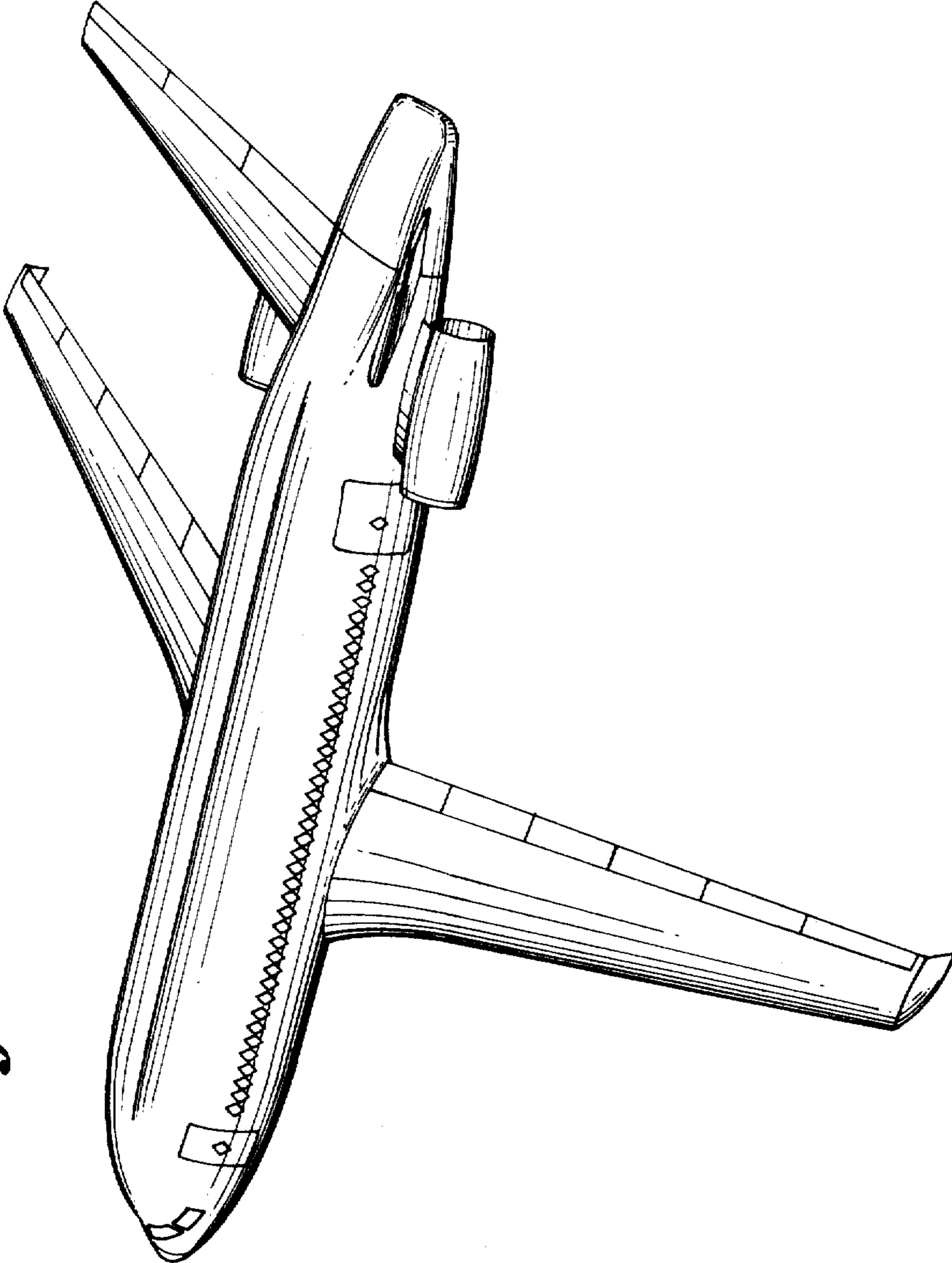

Fig. 5

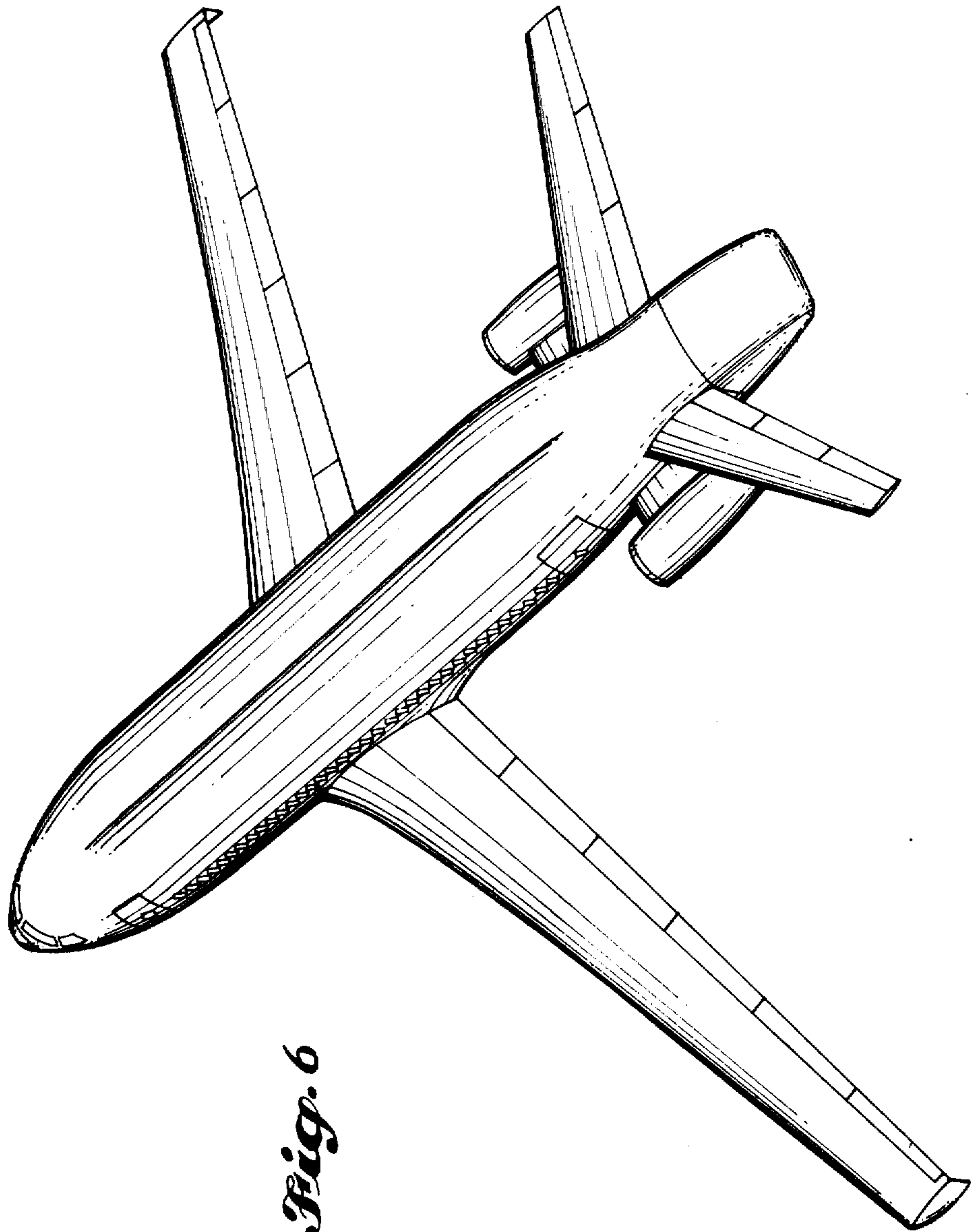

Fig. 6