

[54] AIRCRAFT SEAT

[75] Inventor: **Ralph G. Marrujo**, Winston-Salem, N.C.

[73] Assignee: **Fairchild Industries, Inc.**, Germantown, Md.

[**] Term: **14 Years**

[21] Appl. No.: **281,823**

[22] Filed: **Jul. 9, 1981**

[52] U.S. Cl. **D6/48**

[58] Field of Search **D6/48, 200; 297/144, 297/146, 163, 191, 232, 233, 248**

[56] **References Cited**

U.S. PATENT DOCUMENTS

- D. 180,710 7/1957 Del Giudice D6/48
- D. 225,193 11/1972 Barecki D6/48

- D. 232,883 9/1974 Macnab D6/48
- D. 251,341 3/1979 Bodrero D6/48
- D. 265,960 8/1982 McCarthy D6/200 X

Primary Examiner—Bruce W. Dunkins
Attorney, Agent, or Firm—Michael W. York

[57] **CLAIM**

The ornamental design for an aircraft seat, substantially as shown and described.

DESCRIPTION

FIG. 1 is a rear perspective view of an aircraft seat showing my new design;
 FIG. 2 is a front perspective view thereof;
 FIG. 3 is a rear elevational view of said aircraft seat;
 FIG. 4 is a front elevational view of said aircraft seat; and
 FIG. 5 is an elevational view of the right side of said aircraft seat on an enlarged scale, the left side of said aircraft seat being a mirror image thereof.

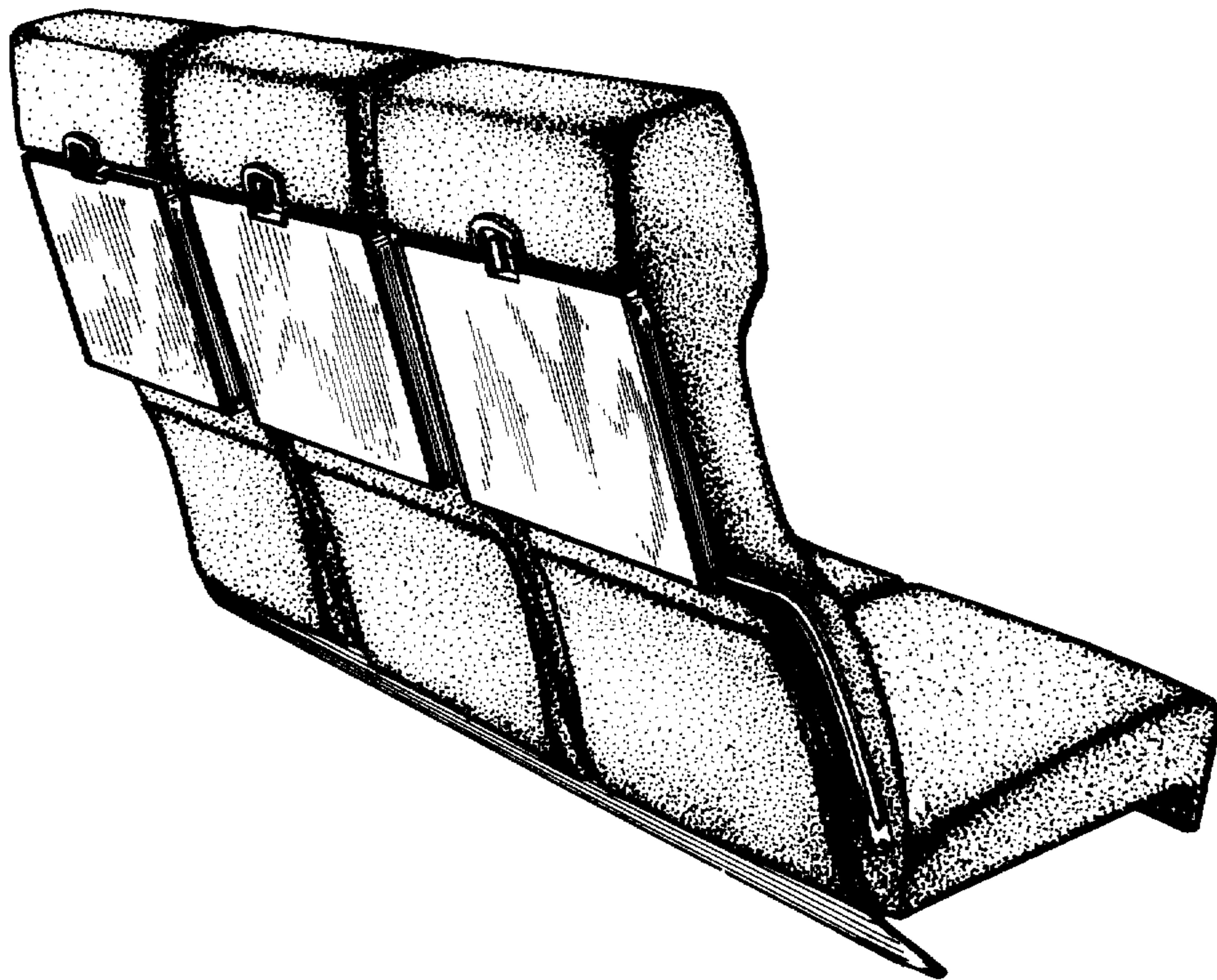

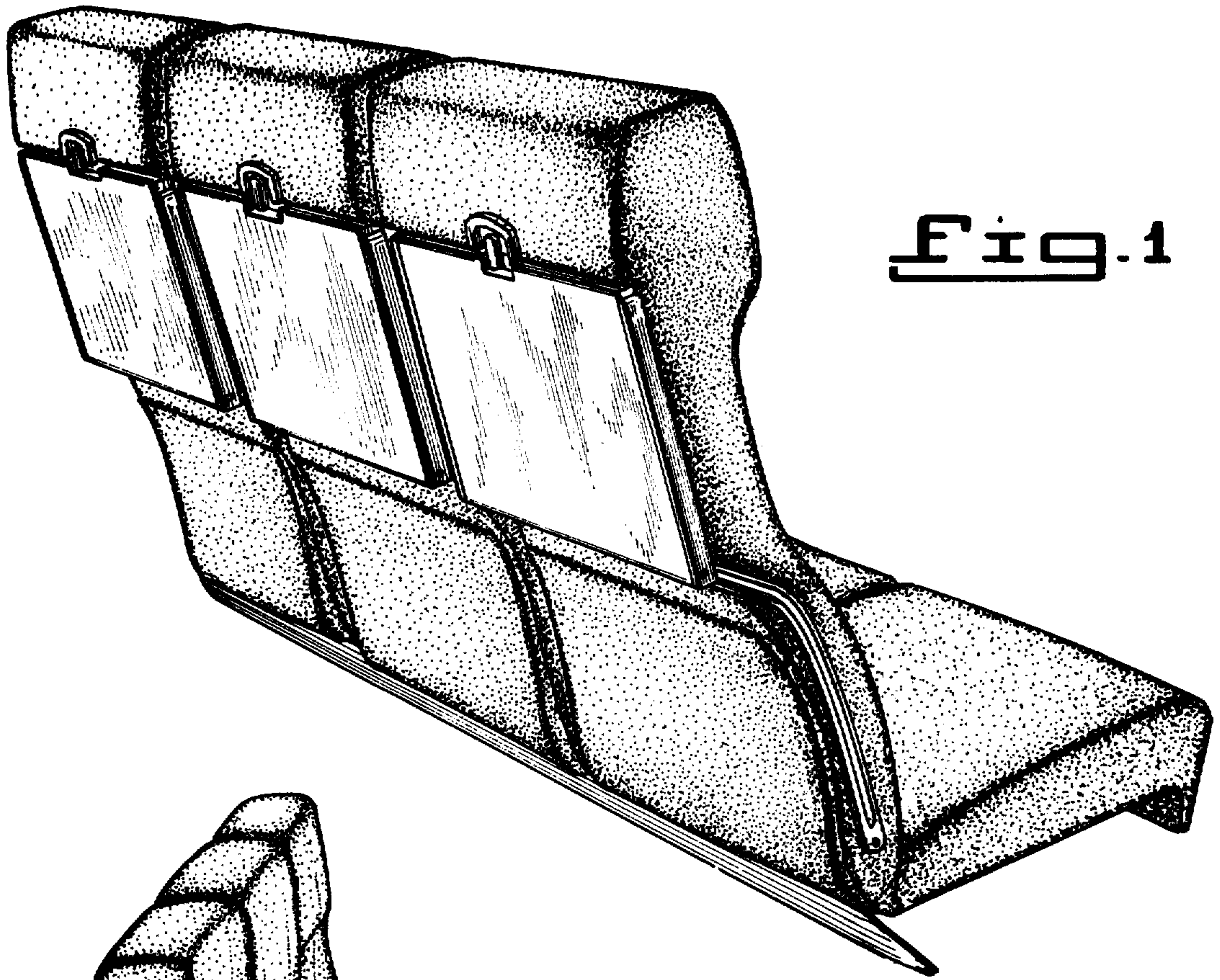

Fig. 1

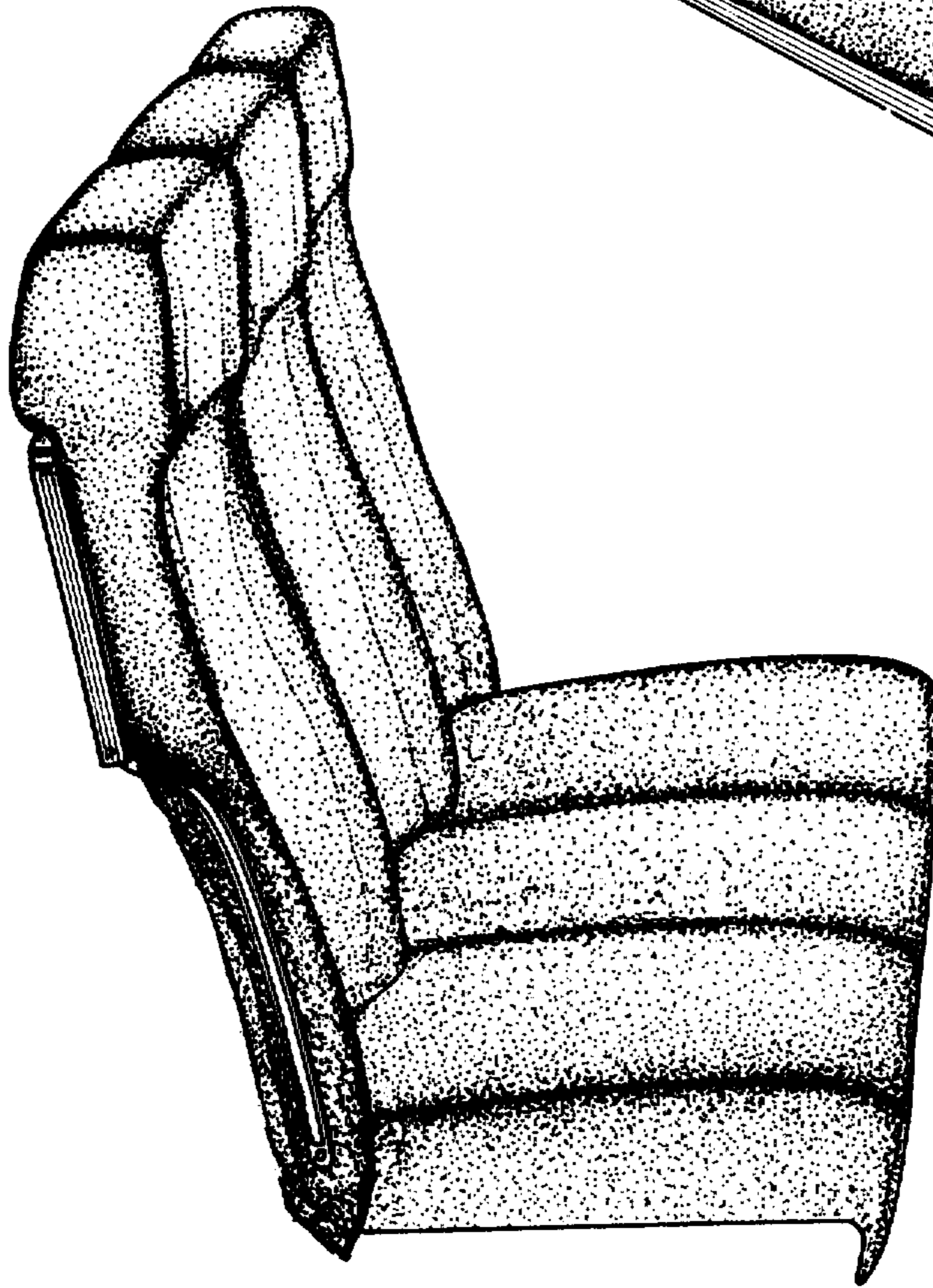
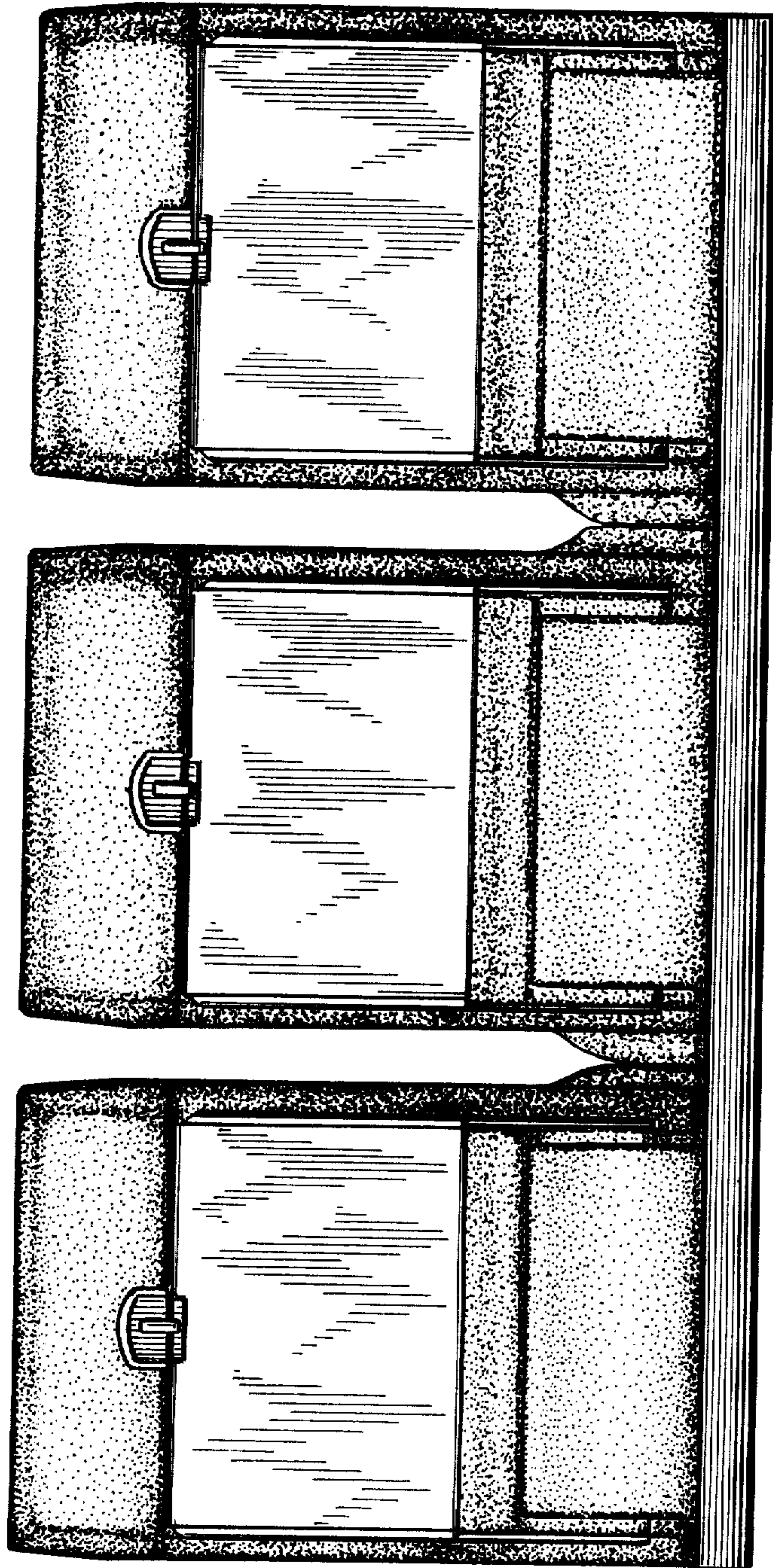

Fig. 2

Fig. 3



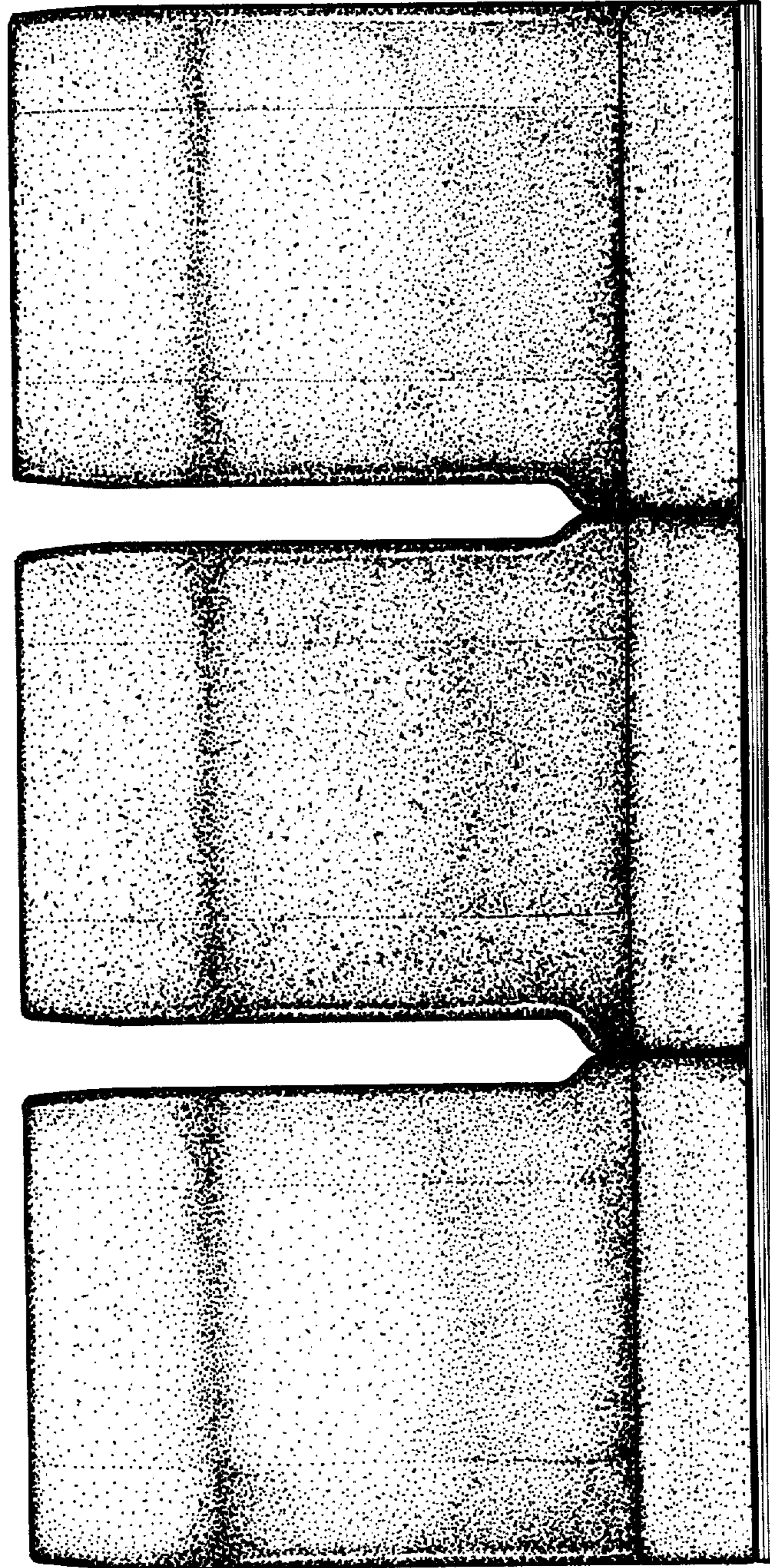

Fig. 4

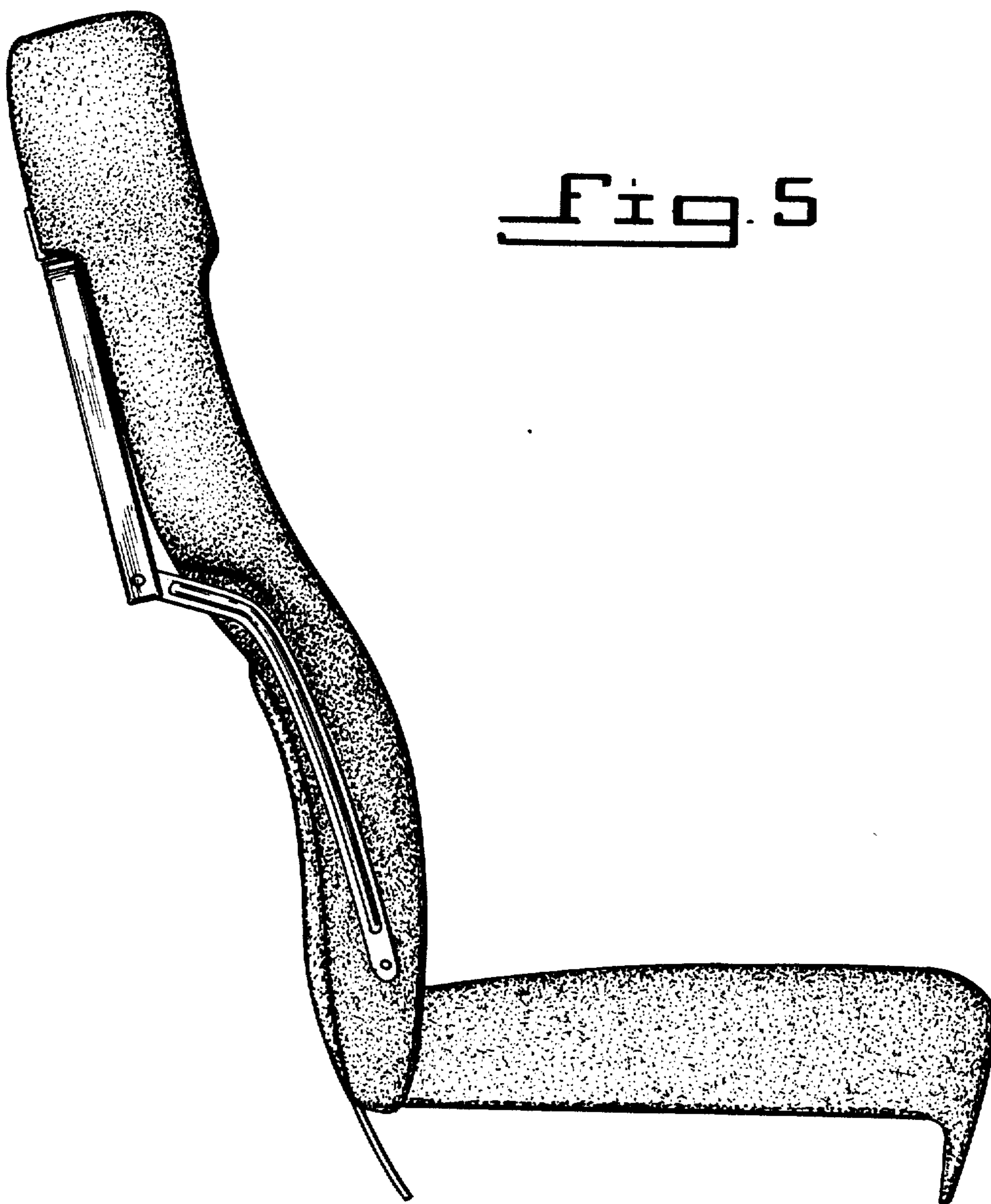

Fig. 5