

[54] HAND CART

[75] Inventor: Stephen R. Zastera, Bloomington, Minn.

[73] Assignee: D.R.I. Industries, Inc., Minneapolis, Minn.

[**] Term: 14 Years

[21] Appl. No.: 326,112

[22] Filed: Nov. 30, 1981

[52] U.S. Cl. D34/17; D34/26

[58] Field of Search D34/17, 21, 26.24; 280/47.18, 47.2, 47.27; 248/98, 129

[56] References Cited

U.S. PATENT DOCUMENTS

D. 249,031	8/1978	Tarran	D34/26
D. 249,032	8/1978	Tarran	D34/17
3,785,669	1/1974	Doheny	D34/17
3,870,261	3/1975	McSwain	248/98
3,950,004	4/1976	Olsson	280/47.18
4,202,521	5/1980	Harding	248/98

OTHER PUBLICATIONS

Material Flow, Inc. Catalog, ©1975, p. 14, Convertible Truck, top left side of page.

Sears Fall & Winter Catalog, 1976, p. 876, Convertible Hand Truck, second cart down from top left side of page.

Primary Examiner—James M. Gandy

[57] CLAIM

The ornamental design for a hand cart, substantially as shown and described.

DESCRIPTION

FIG. 1 is an isometric view of a hand cart showing my new design;

FIG. 2 is an isometric view thereof in an alternate condition;

FIG. 3 is a front elevational view thereof;

FIG. 4 is a right side elevational view thereof;

FIG. 5 is a rear elevational view thereof;

FIG. 6 is a top plan view thereof;

FIG. 7 is a bottom plan view thereof; and

FIG. 8 is an isometric view thereof in another alternate condition.

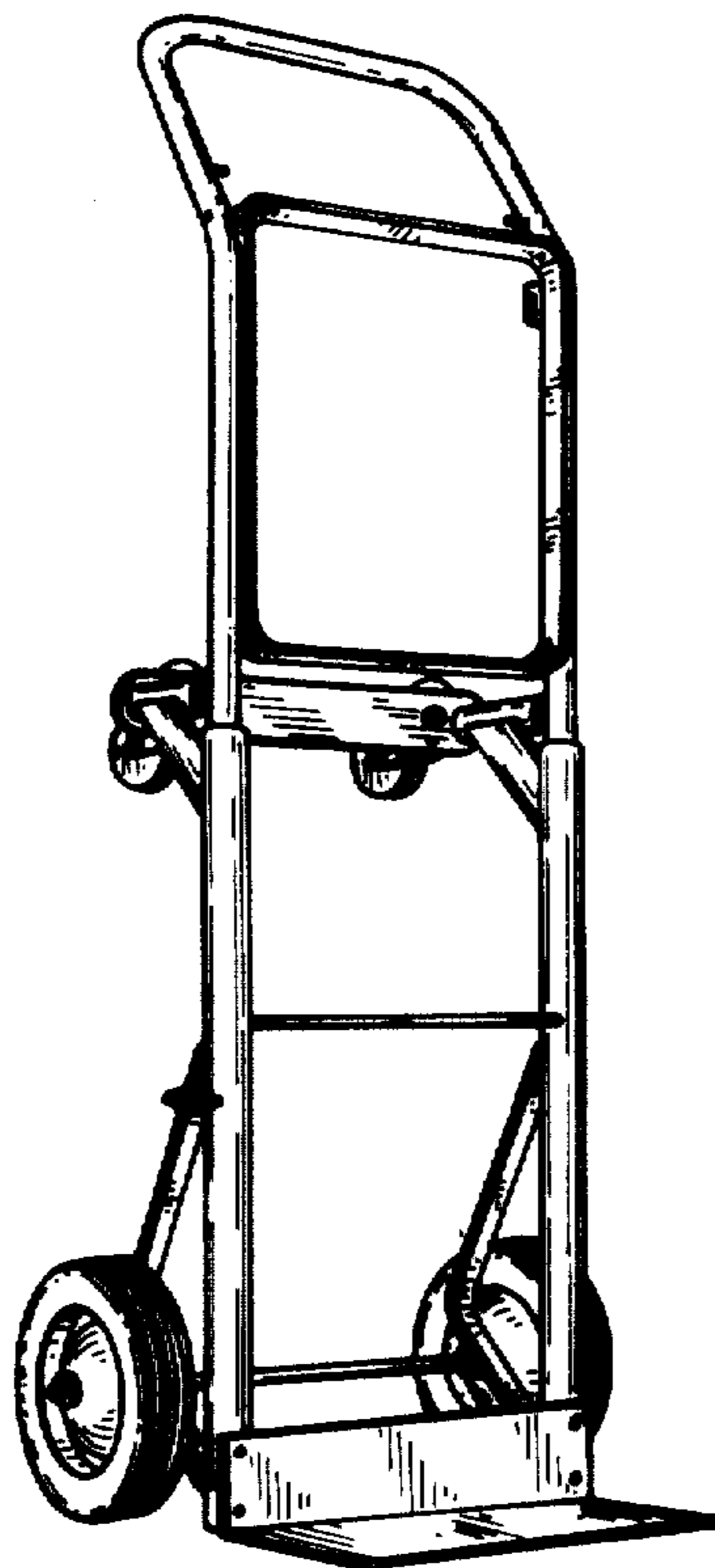

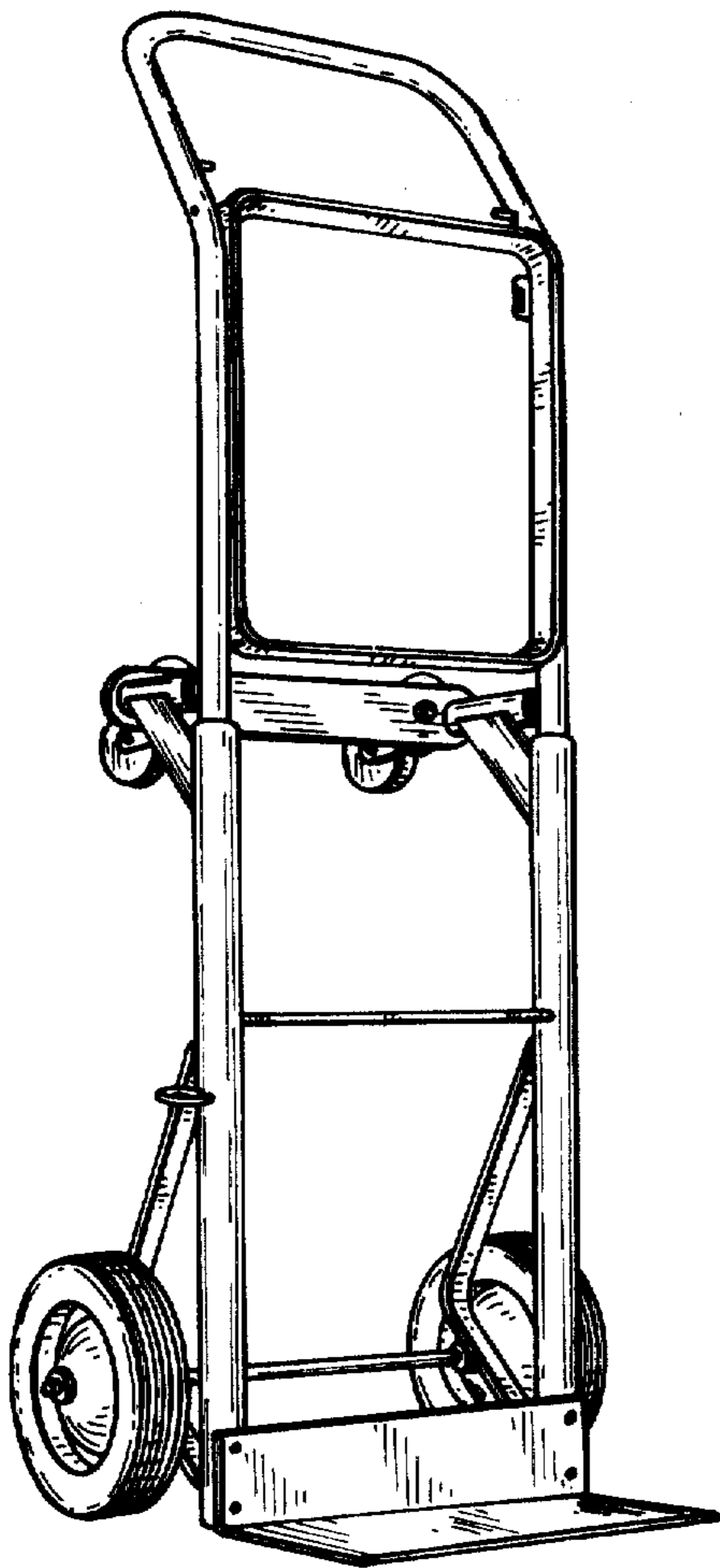

Fig. 1

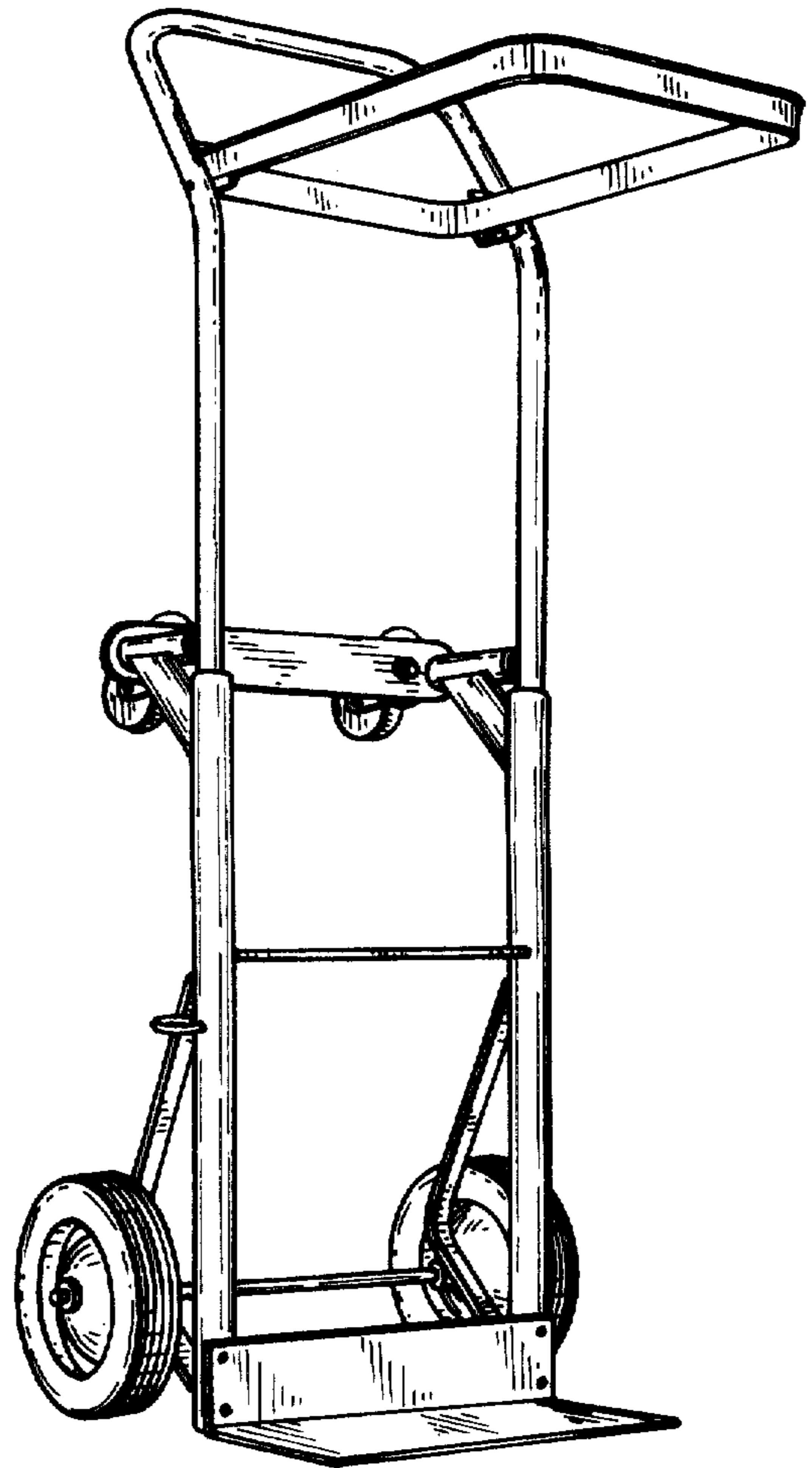

Fig. 2

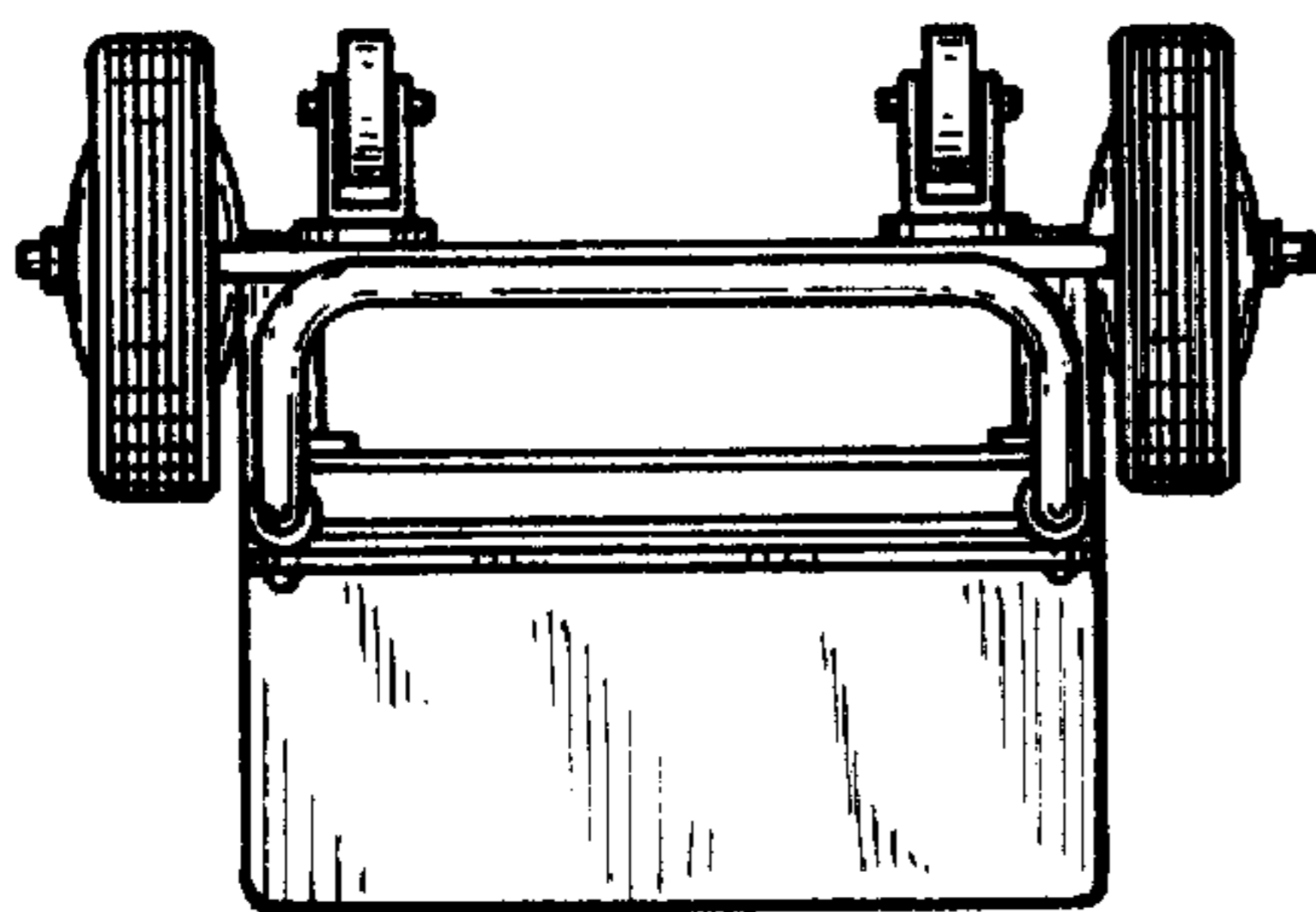

Fig. 6

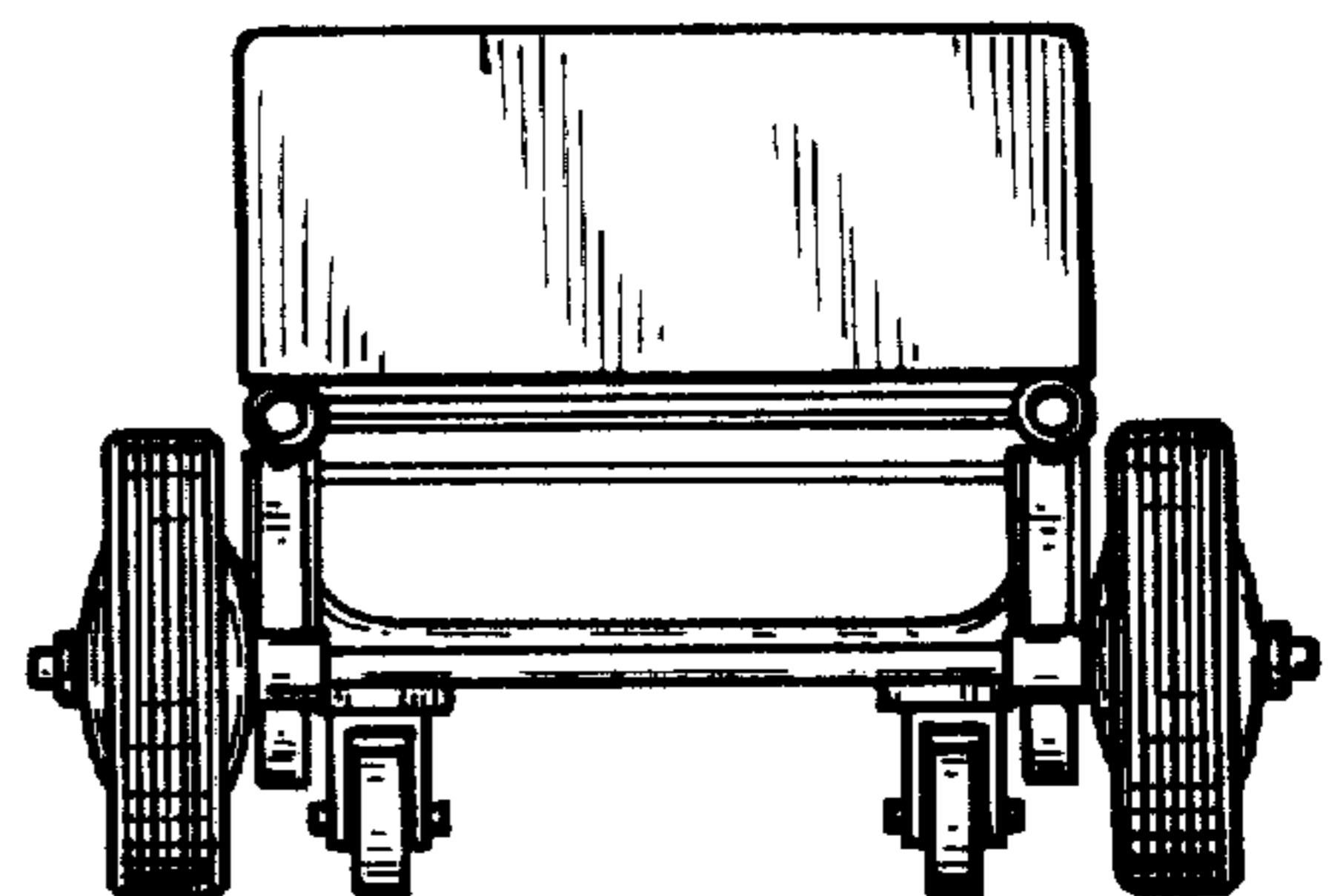

Fig. 7

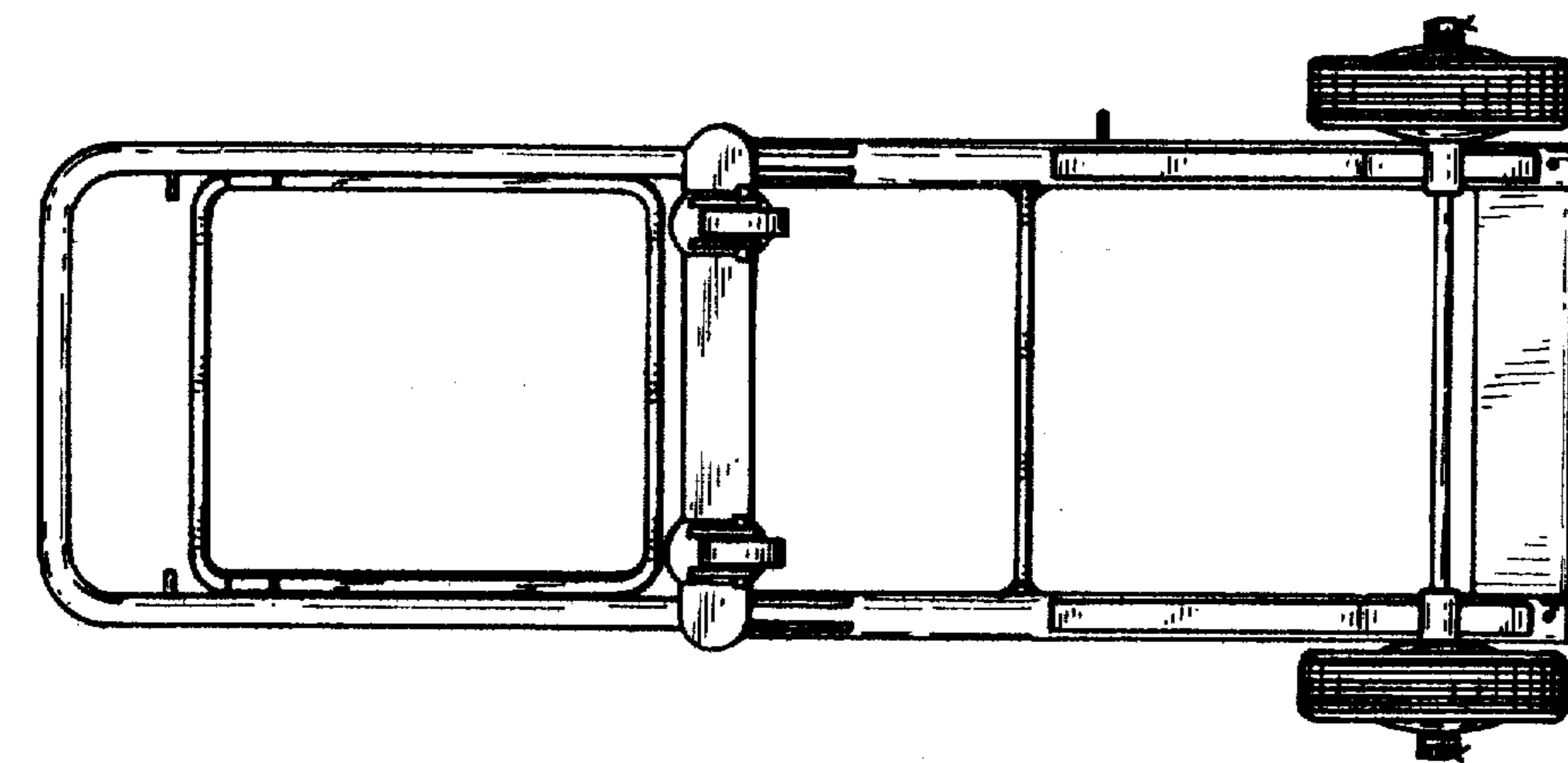

Fig. 3

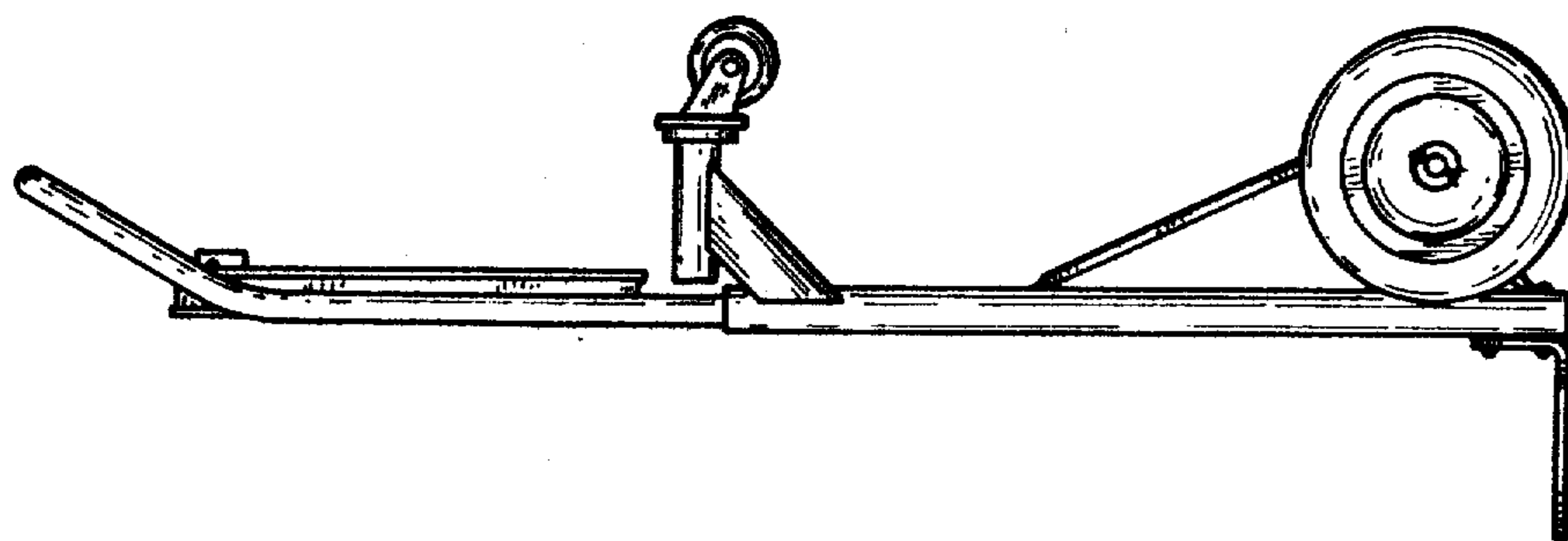

Fig. 4

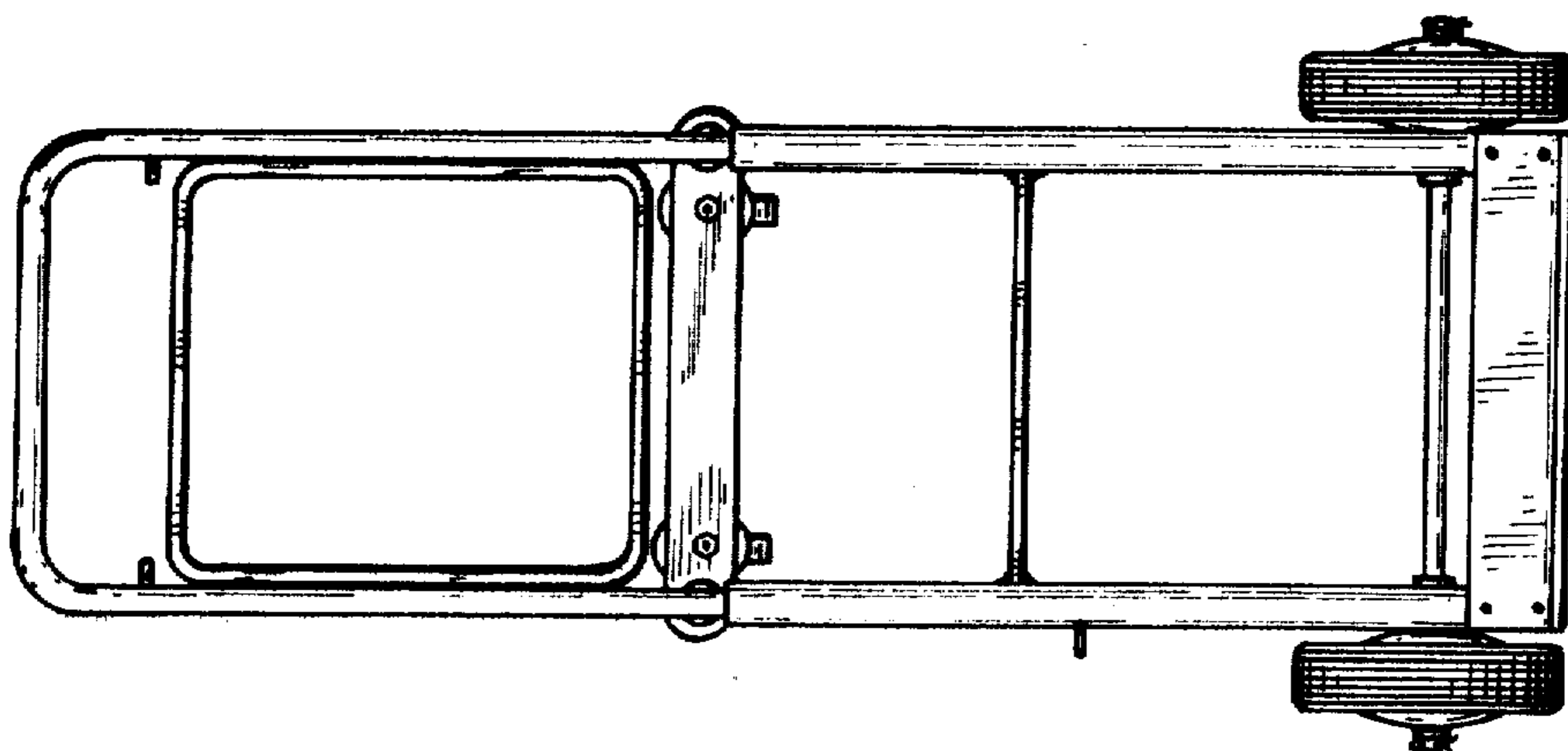

Fig. 5

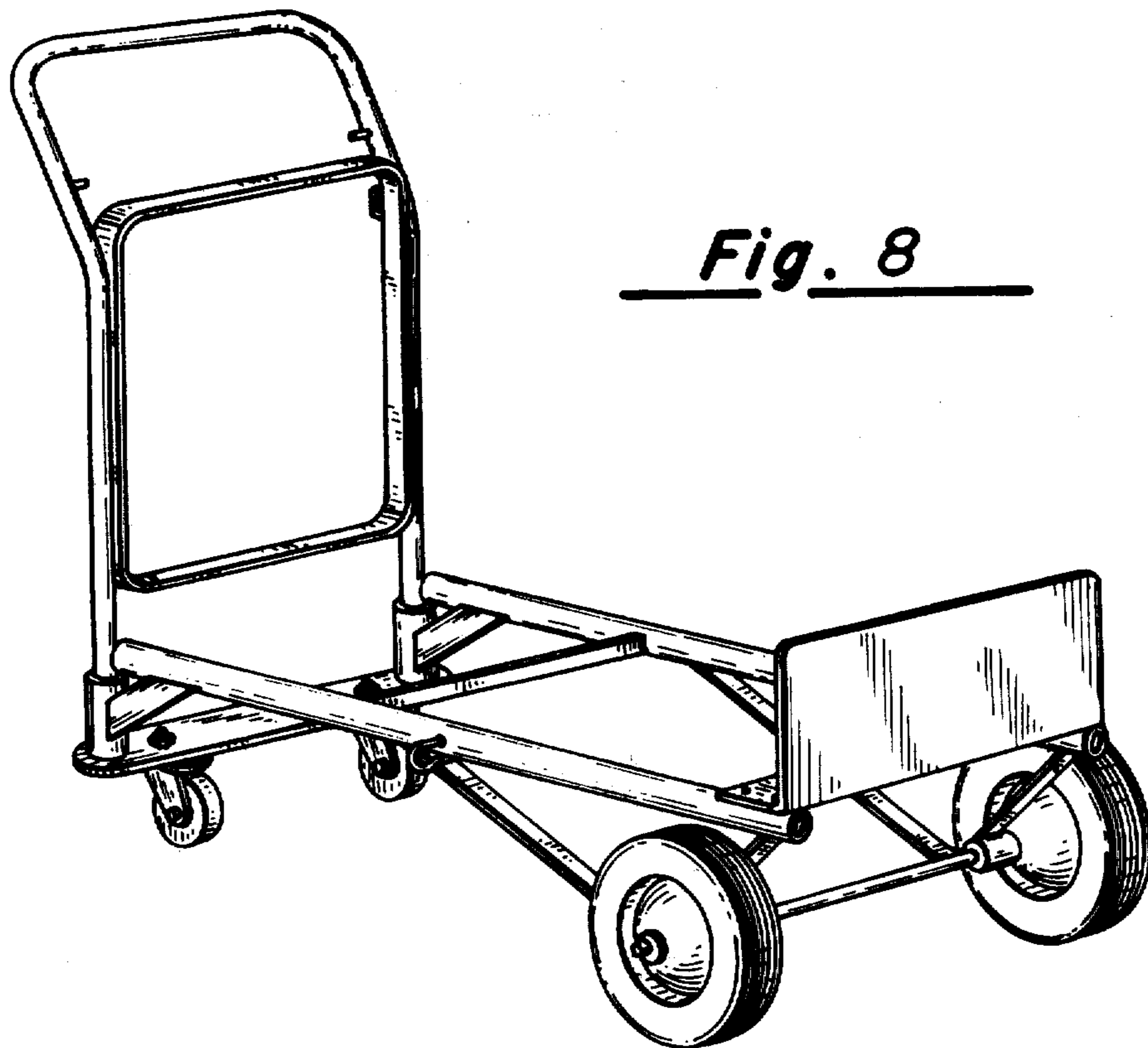

Fig. 8