

[54] **POSITEST THICKNESS GAGE**

[75] Inventor: **Frank Koch**, Ogdensburg, N.Y.

[73] Assignee: **DeFelsko Corporation**, Ogdensburg, N.Y.

[**] Term: **14 Years**

[21] Appl. No.: **314,384**

[22] Filed: **Oct. 23, 1981**

[52] U.S. Cl. **D10/46**

[58] Field of Search **D10/46, 64, 70, 78, D10/81, 103; 33/169 F, 172 R; 324/54**

D. 256,338 8/1980 Kester D10/70
 D. 264,444 5/1982 Muchenberger D10/46
 3,423,837 1/1969 Euverard 33/169 F

Primary Examiner—Nelson C. Holtje
Attorney, Agent, or Firm—Burns, Doane, Swecker & Mathis

[57] **CLAIM**

The ornamental design for a positest thickness gage, as shown and described.

DESCRIPTION

FIG. 1 is a front elevational view of a thickness tester showing my new design;
 FIG. 2 is a top plan view thereof;
 FIG. 3 is a bottom plan view thereof;
 FIG. 4 is a rear elevational view thereof;
 FIG. 5 is a right side elevational view thereof;
 FIG. 6 is a left side elevational view thereof.

[56] **References Cited**
U.S. PATENT DOCUMENTS
 D. 186,549 11/1959 Kennedy D10/103
 D. 254,778 4/1980 Kitada D10/46

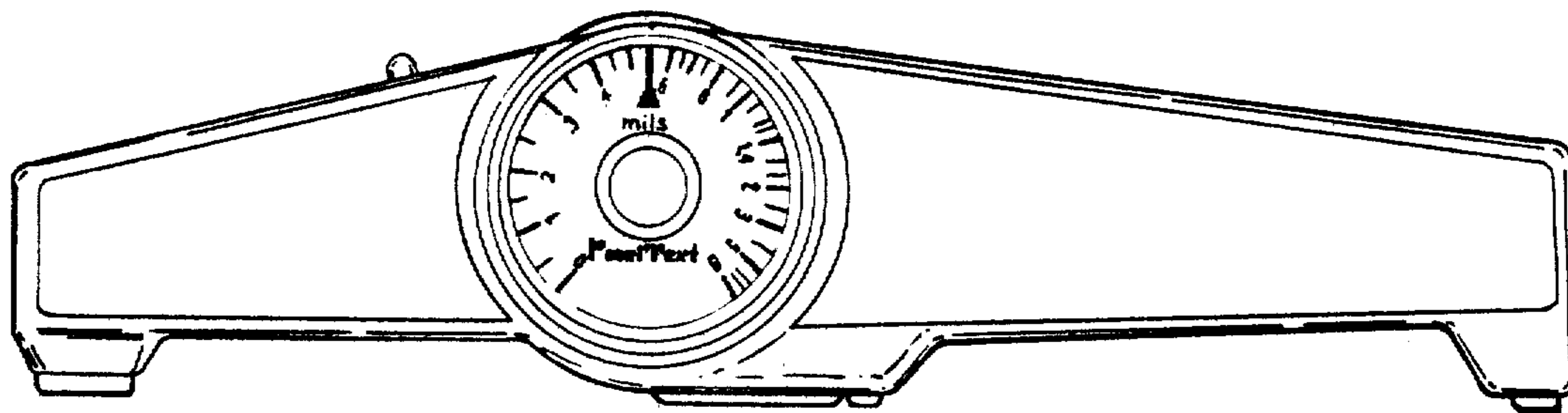

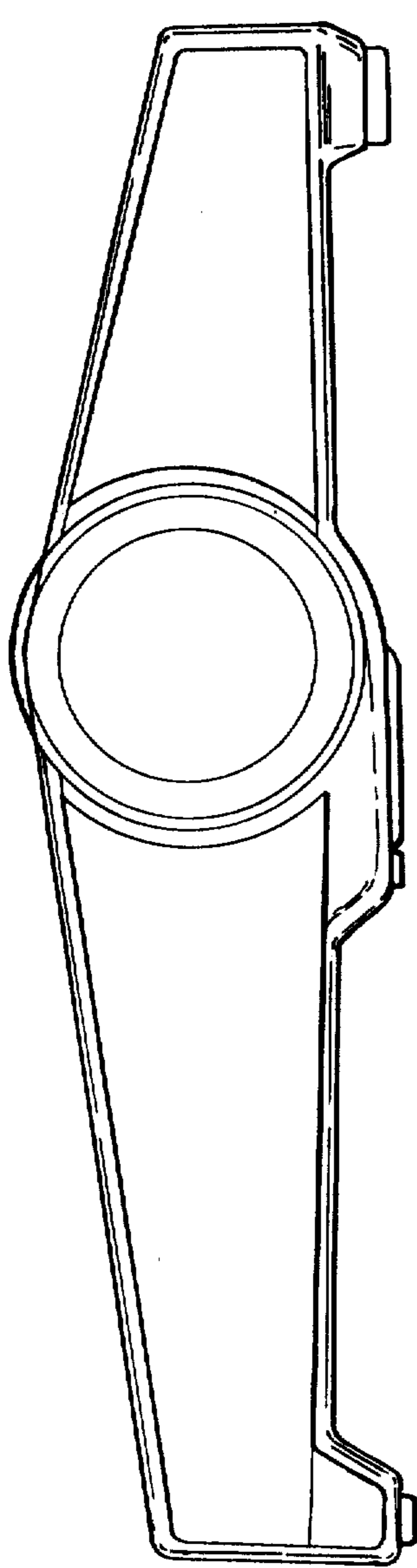

FIG. 1

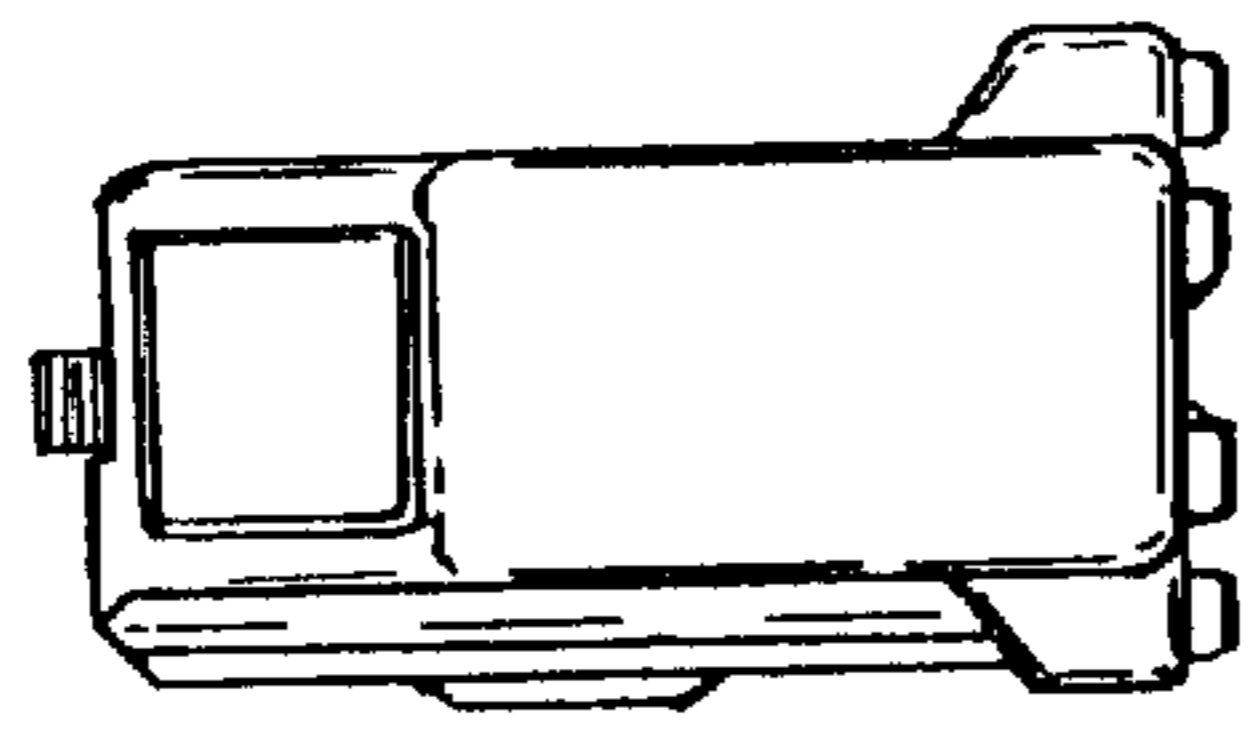

FIG. 2

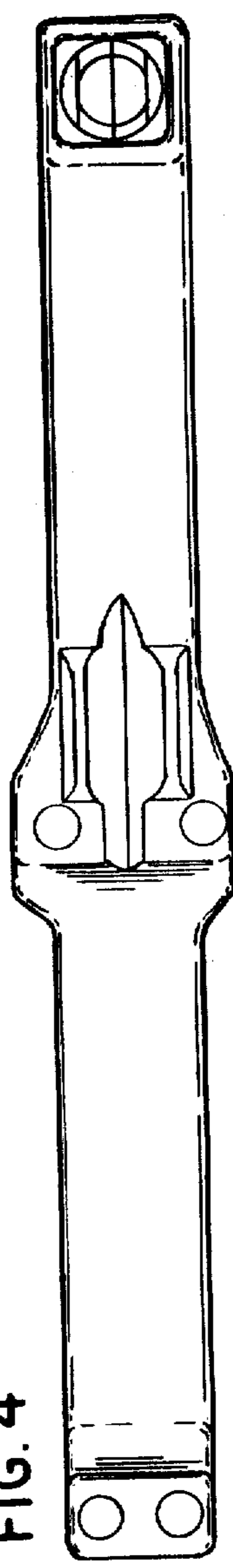

FIG. 3

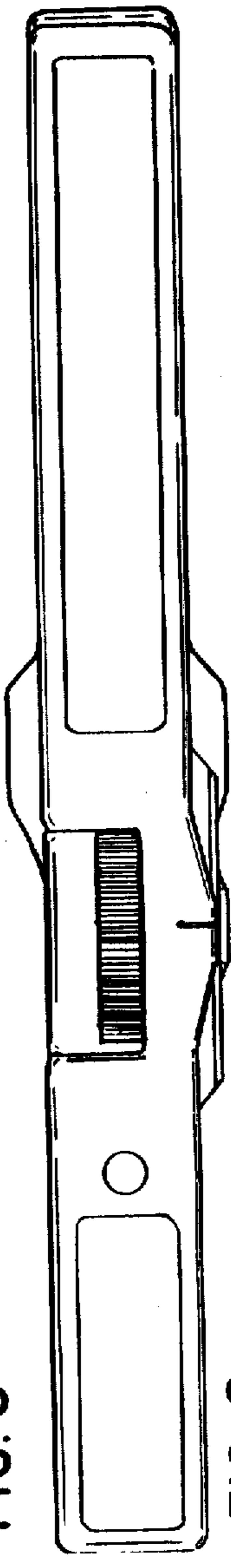

FIG. 4

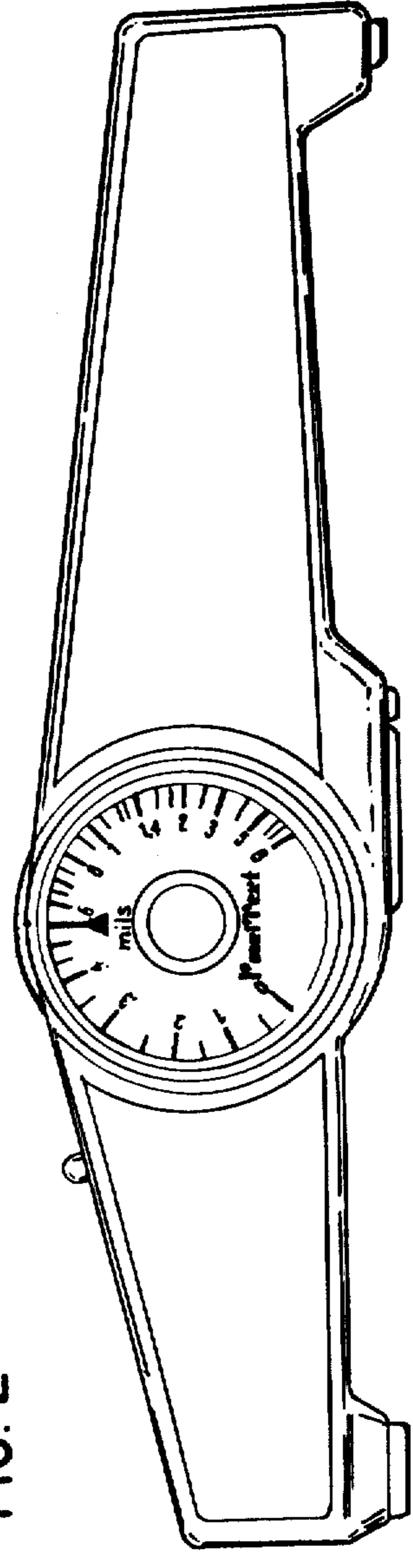

FIG. 5

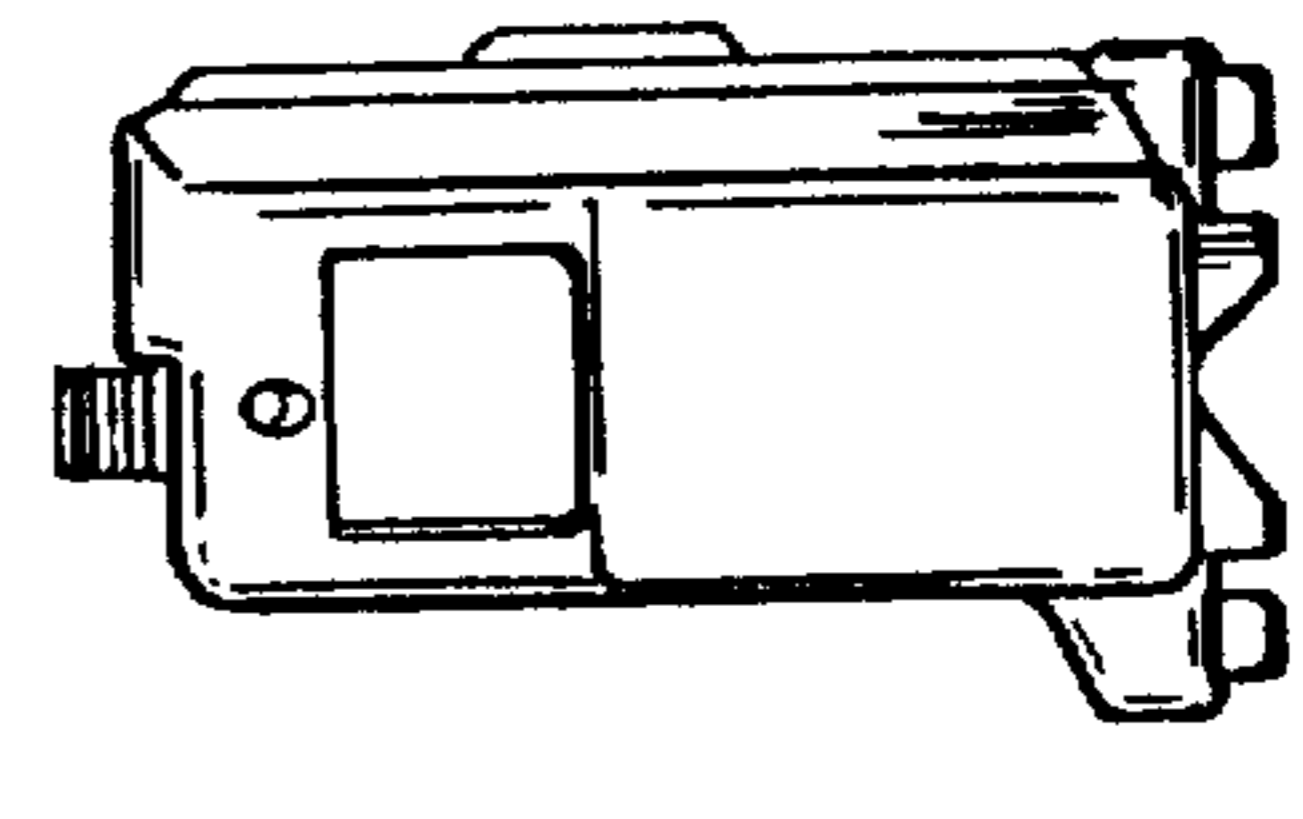

FIG. 6