

[54] CREW CAB

[76] Inventor: Joseph A. Prusak, 145 DeVries Ave., North Tarrytown, N.Y. 10591

[\*\*] Term: 14 Years

[21] Appl. No.: 374,417

[22] Filed: May 3, 1982

[52] U.S. Cl. .... D12/156; D12/13; D15/30

[58] Field of Search ..... D15/10-33; D12/156, 13; 180/69.2, 69.21, 89.1, 89.11, 89.12; 296/102, 190, 192, 10; 239/172

[56] References Cited

U.S. PATENT DOCUMENTS

D. 248,846	8/1978	Stage et al. ....	D12/156
D. 267,935	2/1983	Robinett et al. ....	D12/13
3,191,712	6/1965	Dodge .....	296/190
3,940,177	2/1976	Mierb et al. ....	180/89.12
4,082,343	4/1978	Hurt et al. ....	180/89.12

OTHER PUBLICATIONS

Ware Bros. Co., Aug. 1924, p. 64, (Motor Vehicle

Monthly), Babcock Flexible Steel-Wood Cab on lower middle of page.

Primary Examiner—Bernard Ansher  
Assistant Examiner—Suzanne N. Gitlin  
Attorney, Agent, or Firm—Natter & Natter

[57] CLAIM

The ornamental design for a crew cab, as shown and described.

DESCRIPTION

FIG. 1 is a front left side perspective view of a crew cab showing my new design;  
FIG. 2 is a rear right side perspective view thereof;  
FIG. 3 is an enlarged scale front elevational view thereof;  
FIG. 4 is an enlarged scale side elevational view taken from the right of FIG. 1;  
FIG. 5 is an enlarged scale top plan view thereof; and  
FIG. 6 is an enlarged scale rear elevational view thereof.

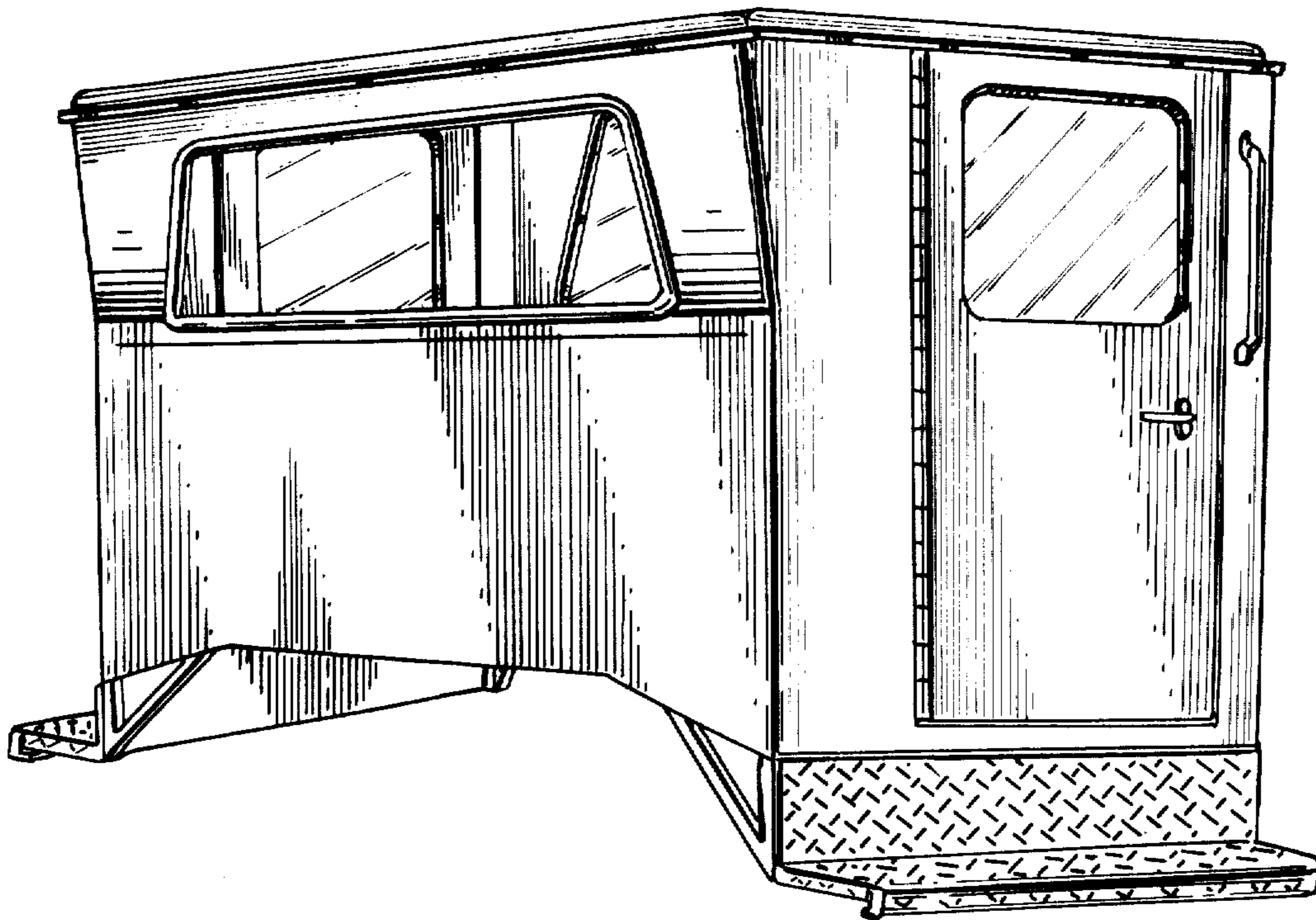

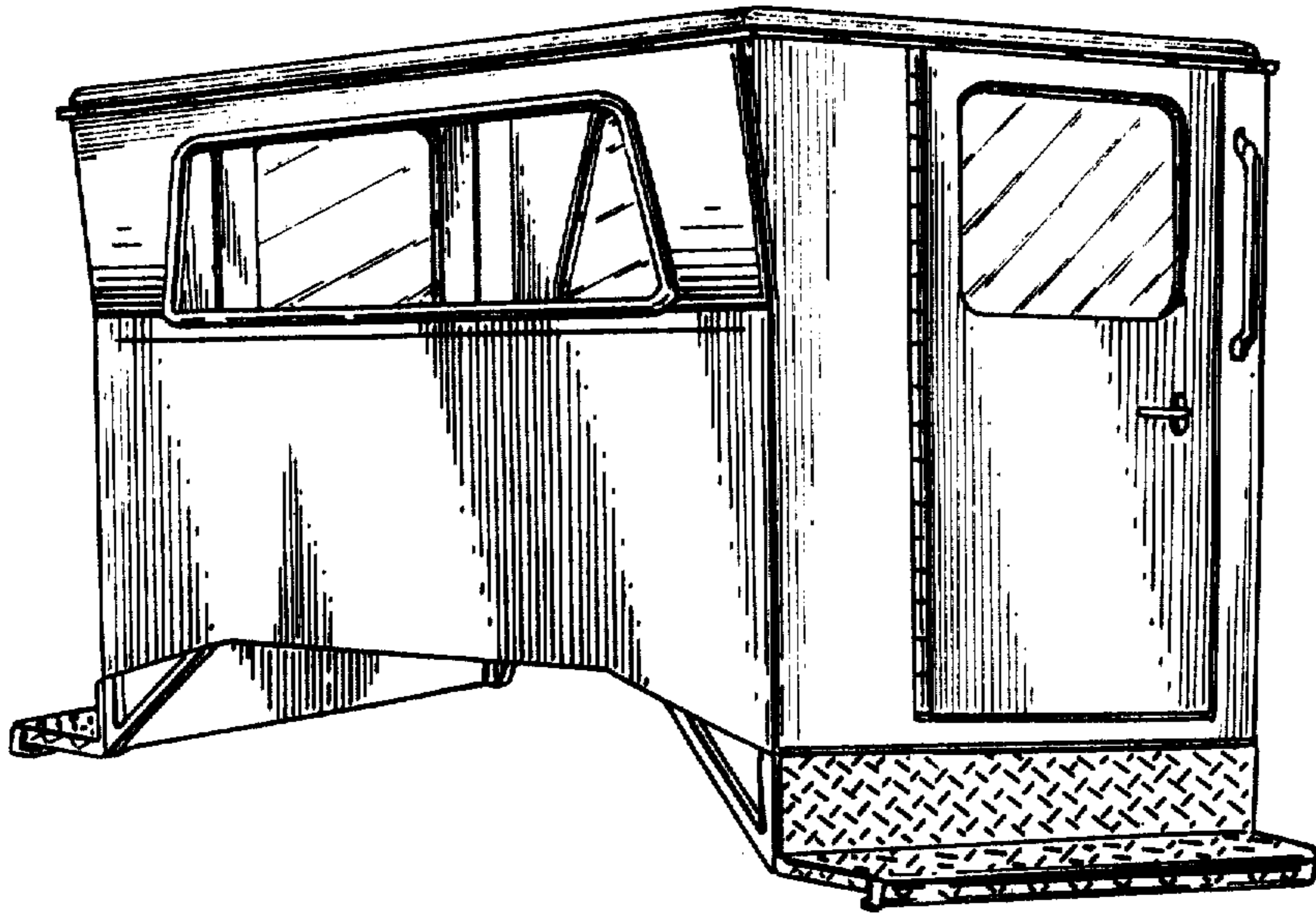

FIG. 1

FIG. 2

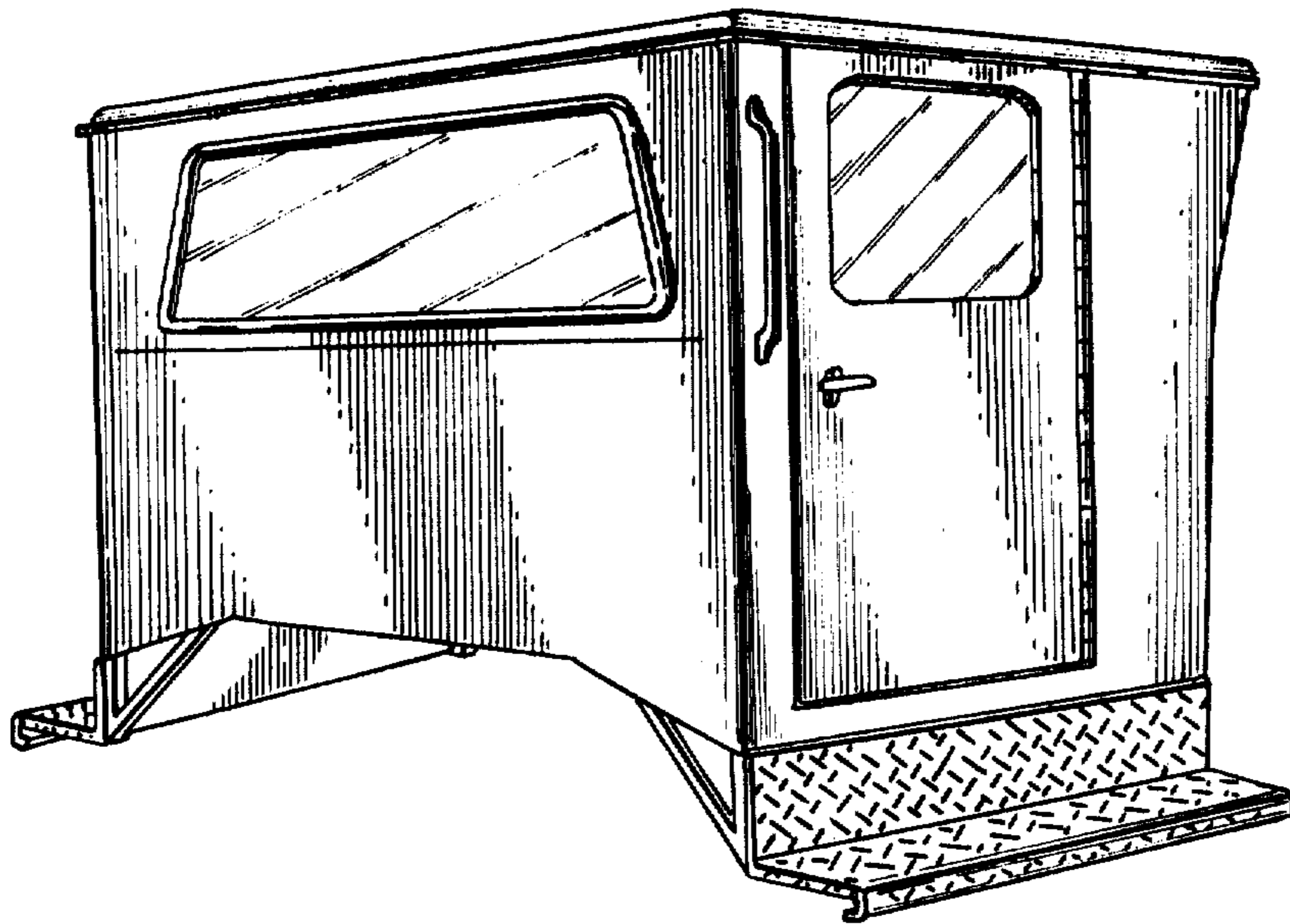

FIG. 3

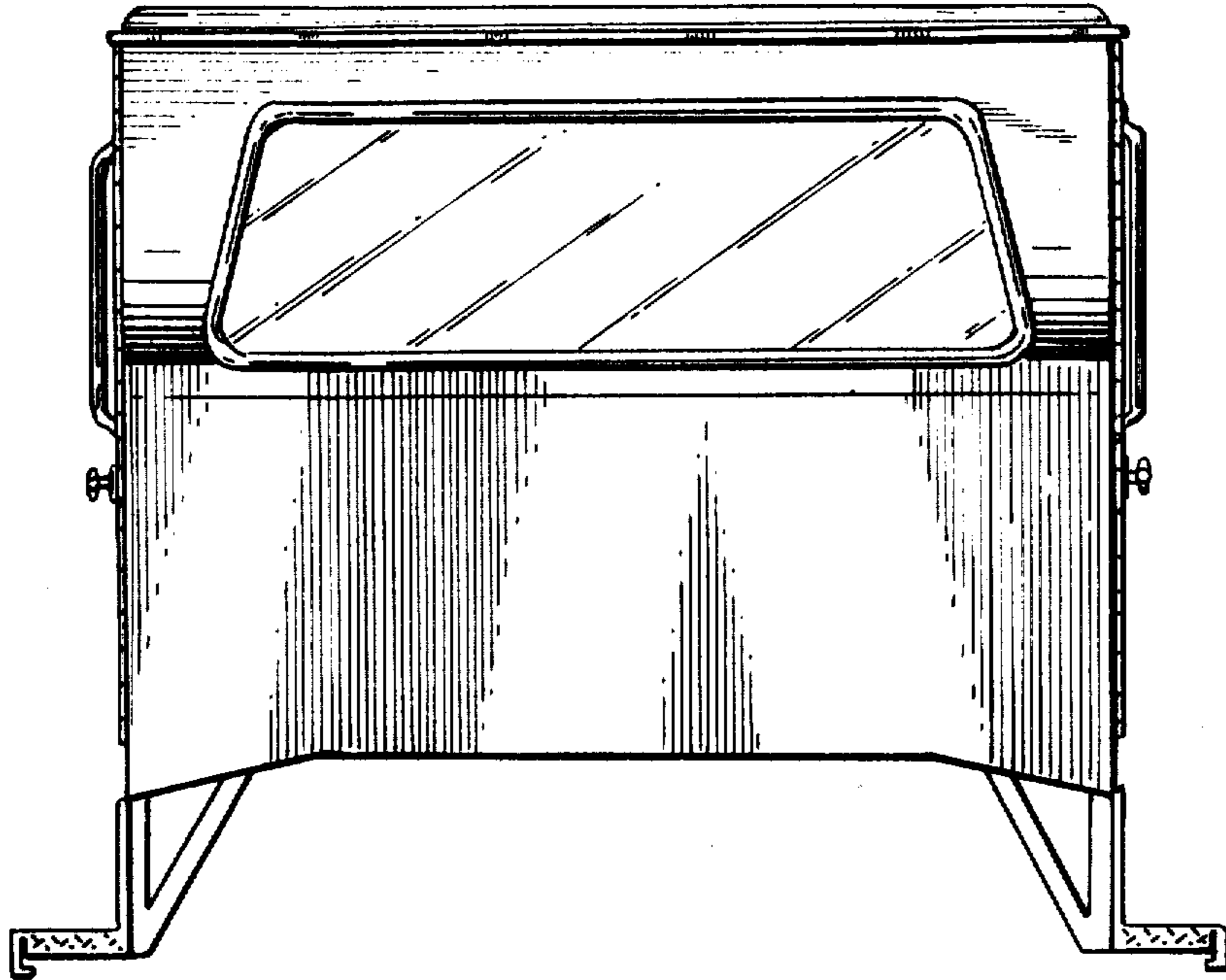

FIG. 6

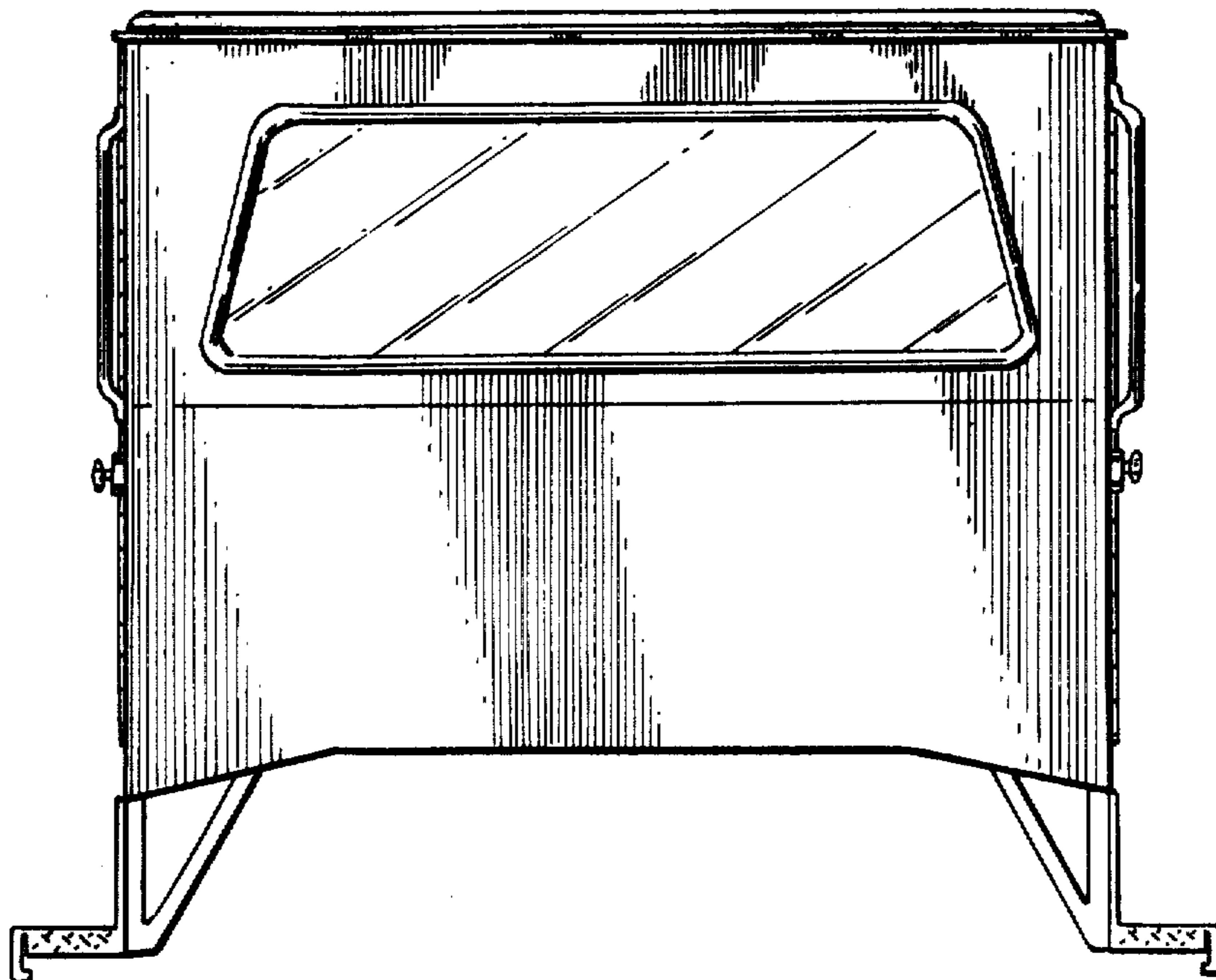



FIG. 4

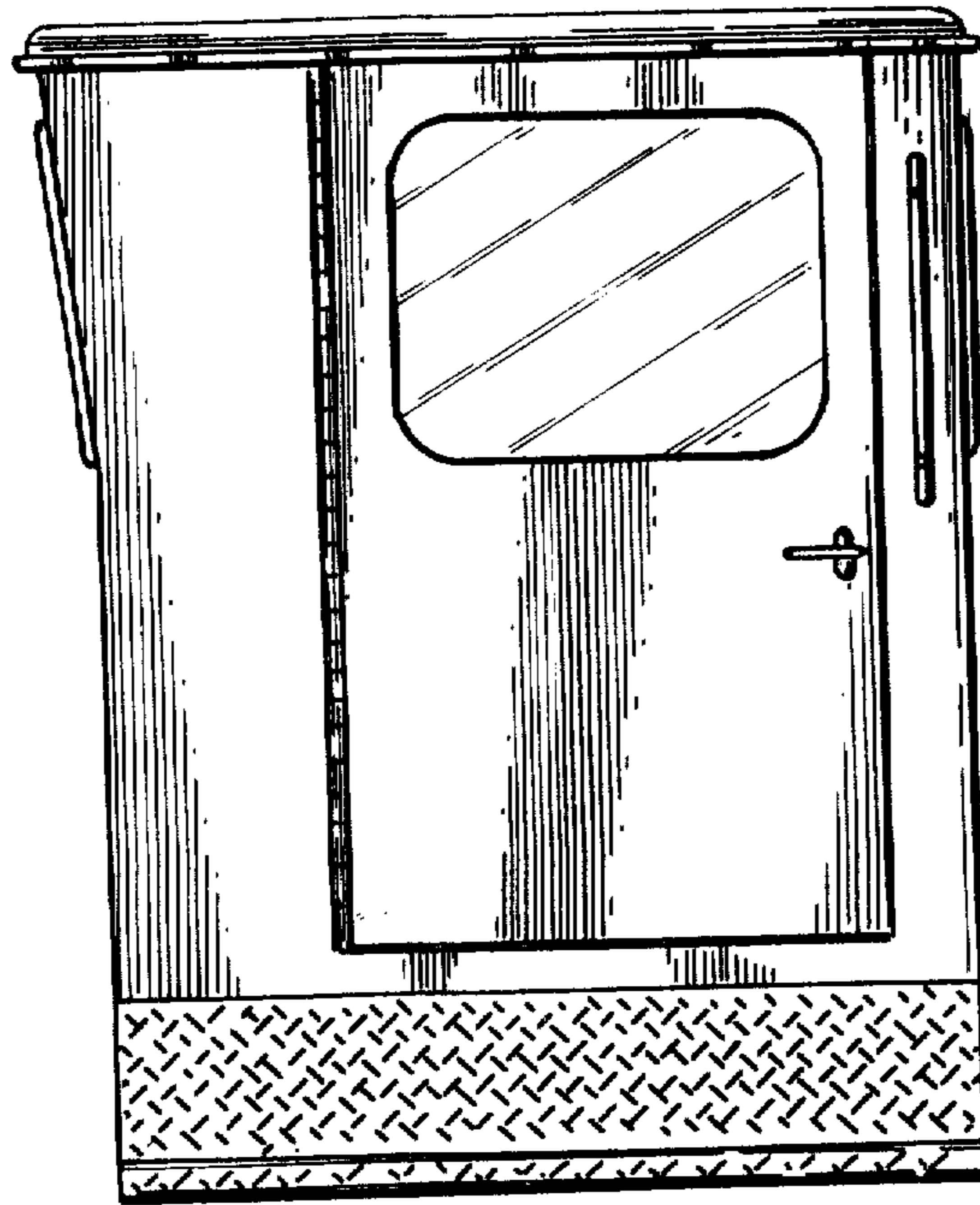

FIG. 5

