

[54] COMBINED LAMP AND POWERBOARD

2,938,110 5/1960 Busch et al. 362/258
4,136,381 1/1979 Bone 362/387 X

[76] Inventor: Francis R. Bannigan, 64 Duerdin St.,
North Clayton, Victoria, 3168,
Australia

Primary Examiner—Susan J. Lucas
Attorney, Agent, or Firm—Scully, Scott, Murphy and
Presser

[**] Term: 14 Years

[57] CLAIM

[21] Appl. No.: 227,206

The ornamental design for combined lamp and power-
board, as shown and described.

[22] Filed: Jan. 22, 1981

[52] U.S. Cl. D26/51; D26/37;
D26/104

DESCRIPTION

[58] Field of Search D26/51, 37; 104/50;
112/119; 362/157, 158, 200-208, 258, 387, 184,
185, 186, 189, 190, 191, 194, 197

FIG. 1 is a perspective view of the combined lamp and
powerboard showing my new design,
FIG. 2 is a plan view of the combined lamp and power-
board on a reduced scale,
FIG. 3 is a rear view of the combined lamp and power-
board on a reduced scale,
FIG. 4 is a side view of the combined lamp and power-
board on a reduced scale, and
FIG. 5 is an underneath view of the combined lamp and
powerboard on a reduced scale.

[56] References Cited

U.S. PATENT DOCUMENTS

D. 244,715 6/1977 Fierro et al. D26/119 X
1,705,239 3/1929 De Lorme 362/398
2,863,038 12/1958 Lombardo D26/38 X

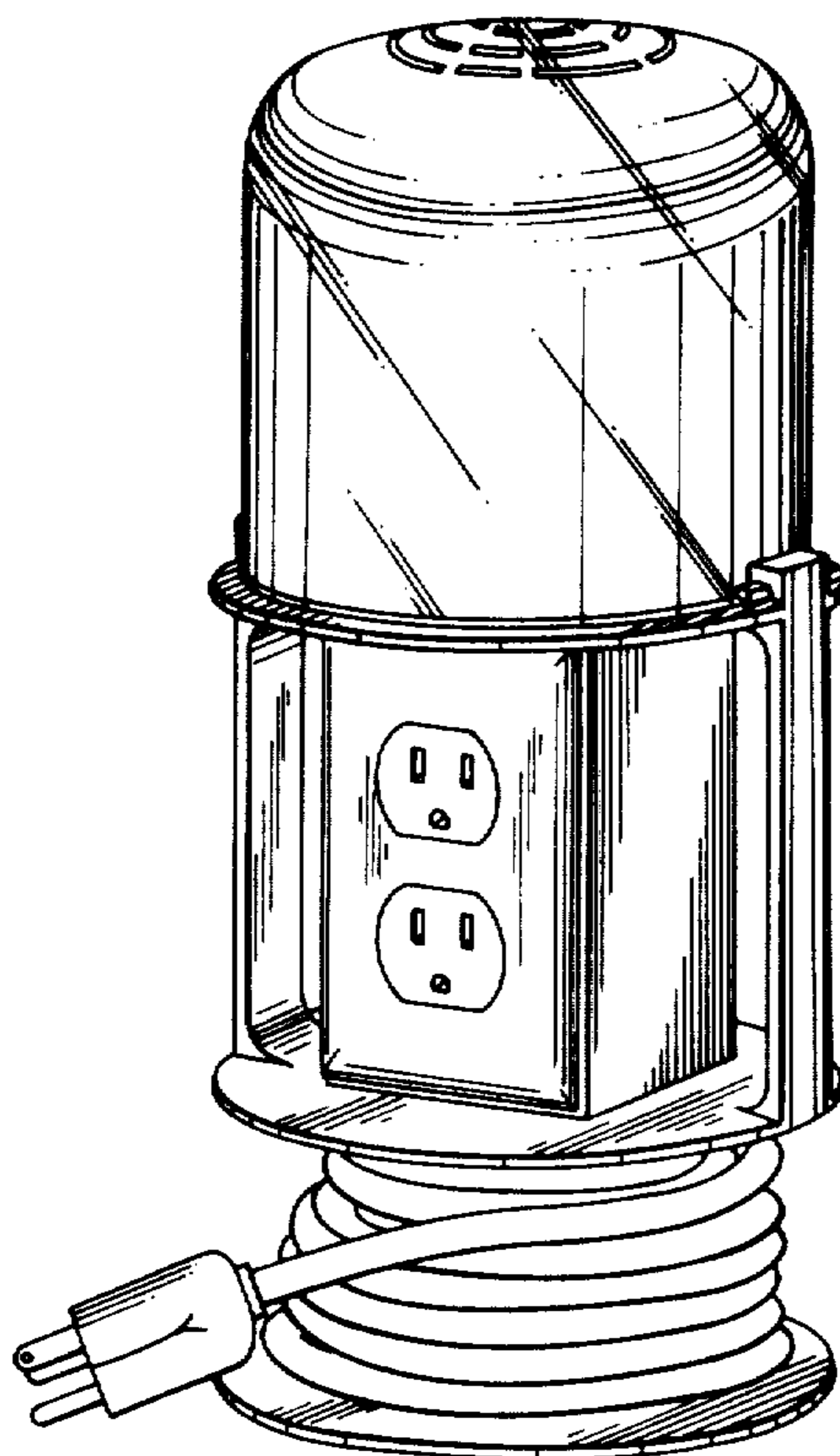

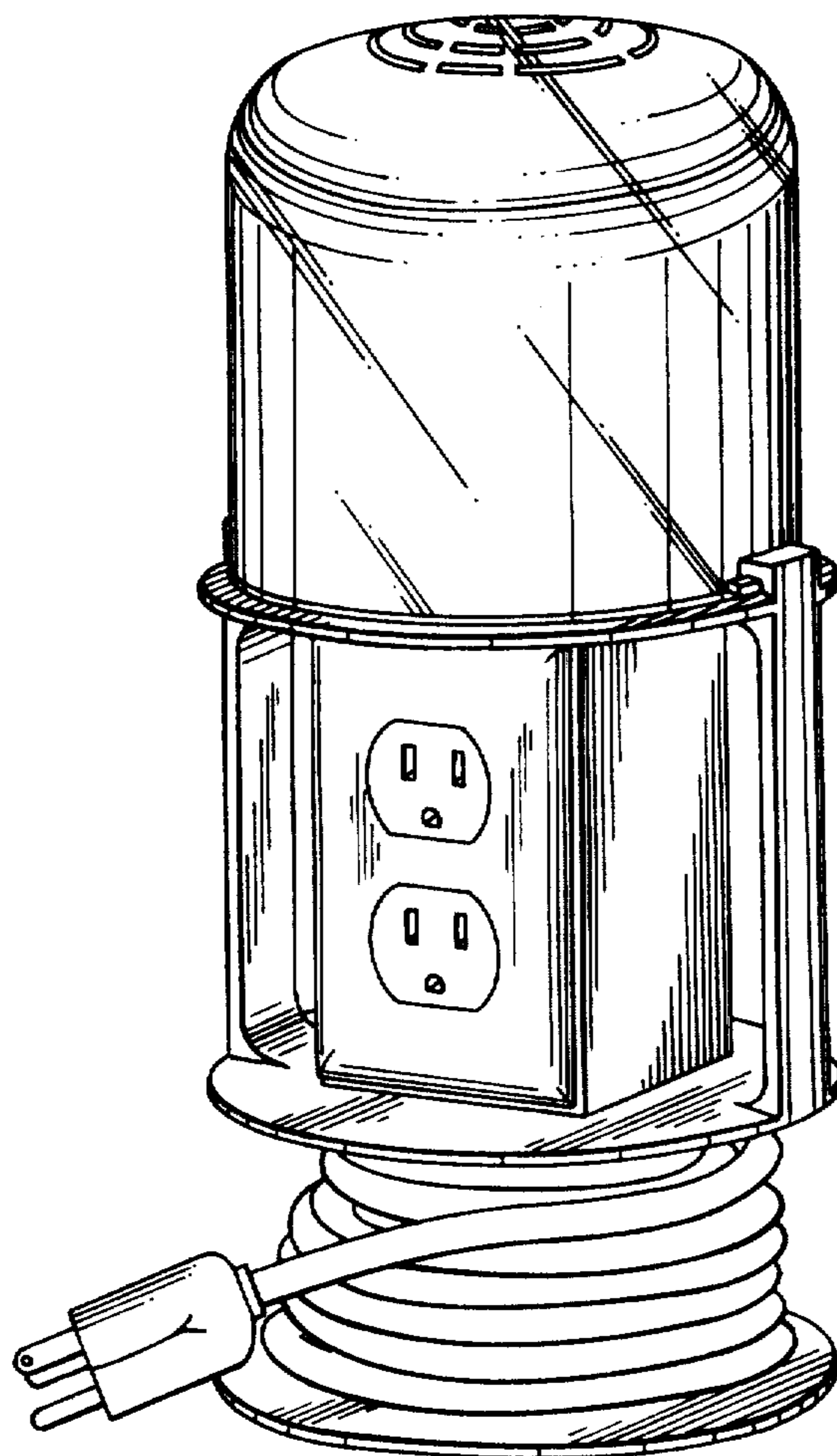

FIG. 1

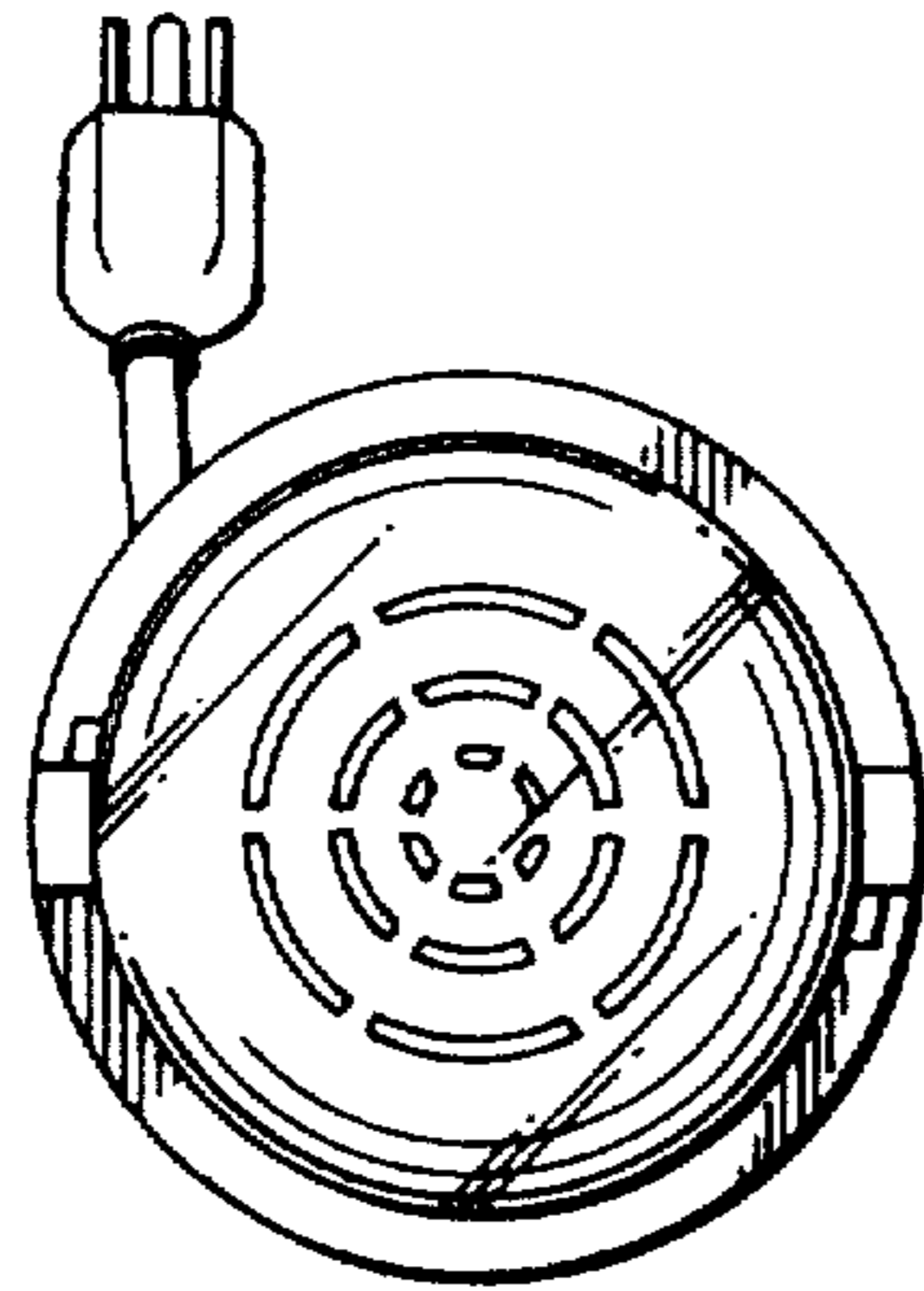

FIG. 2

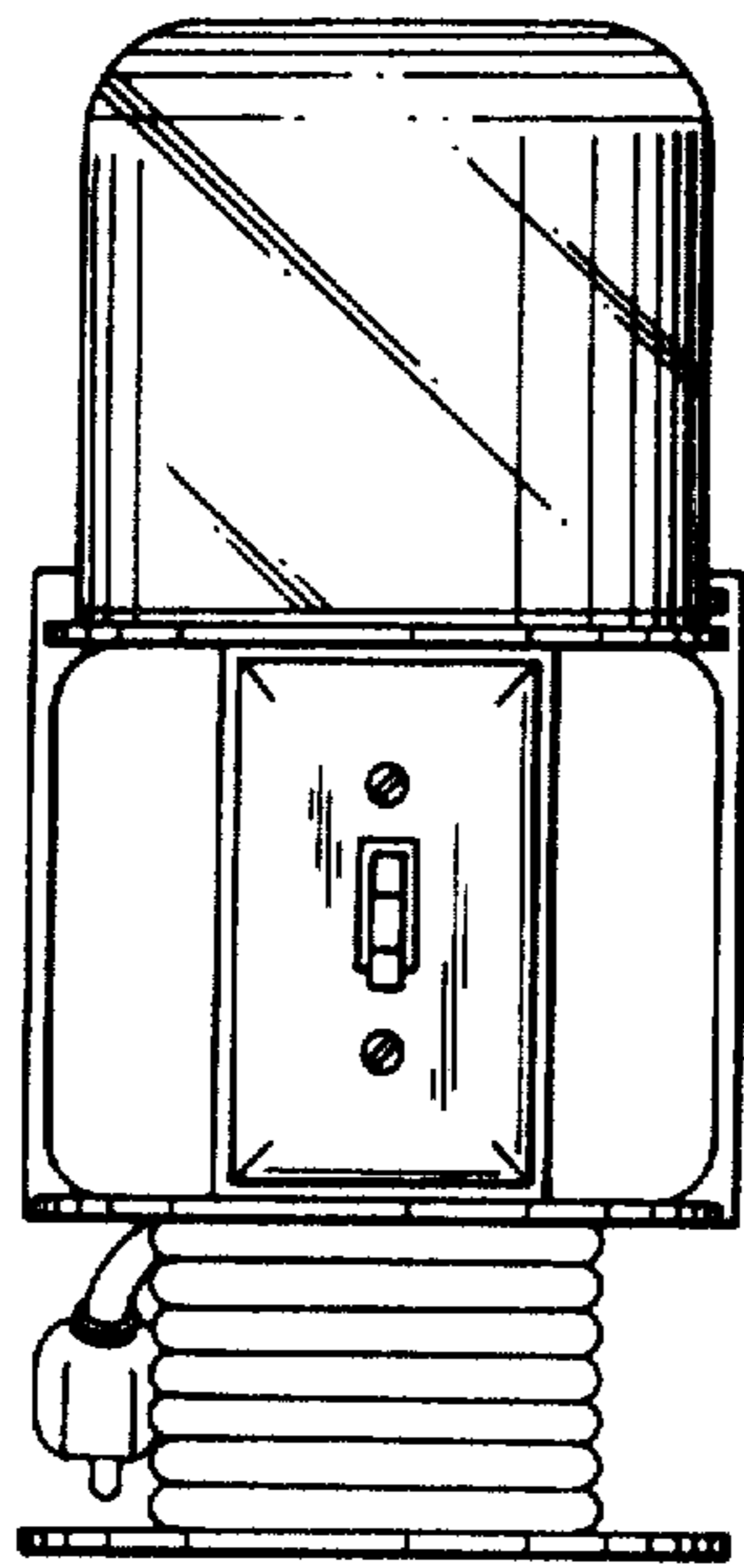

FIG. 3

4

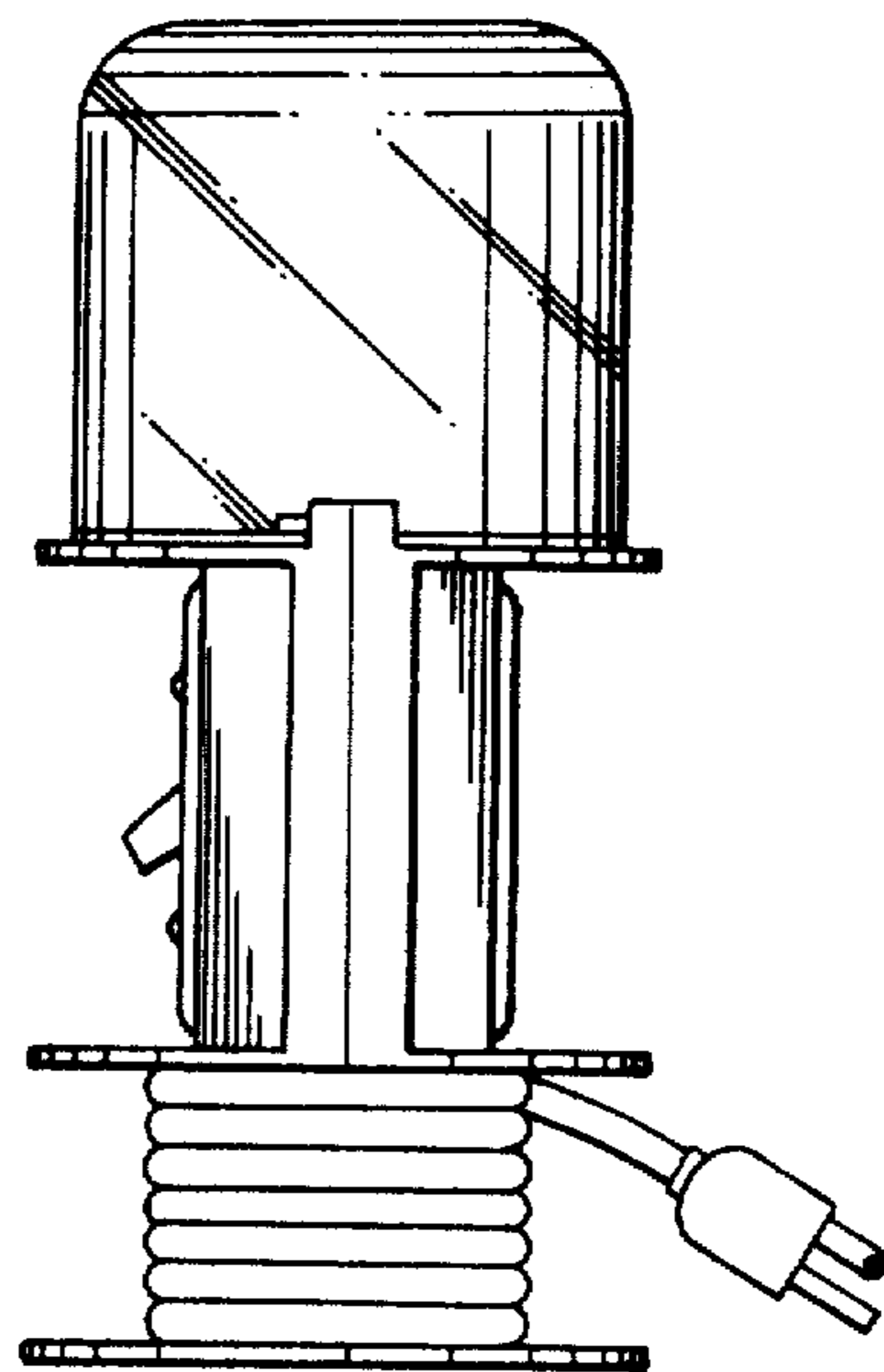

FIG. 4

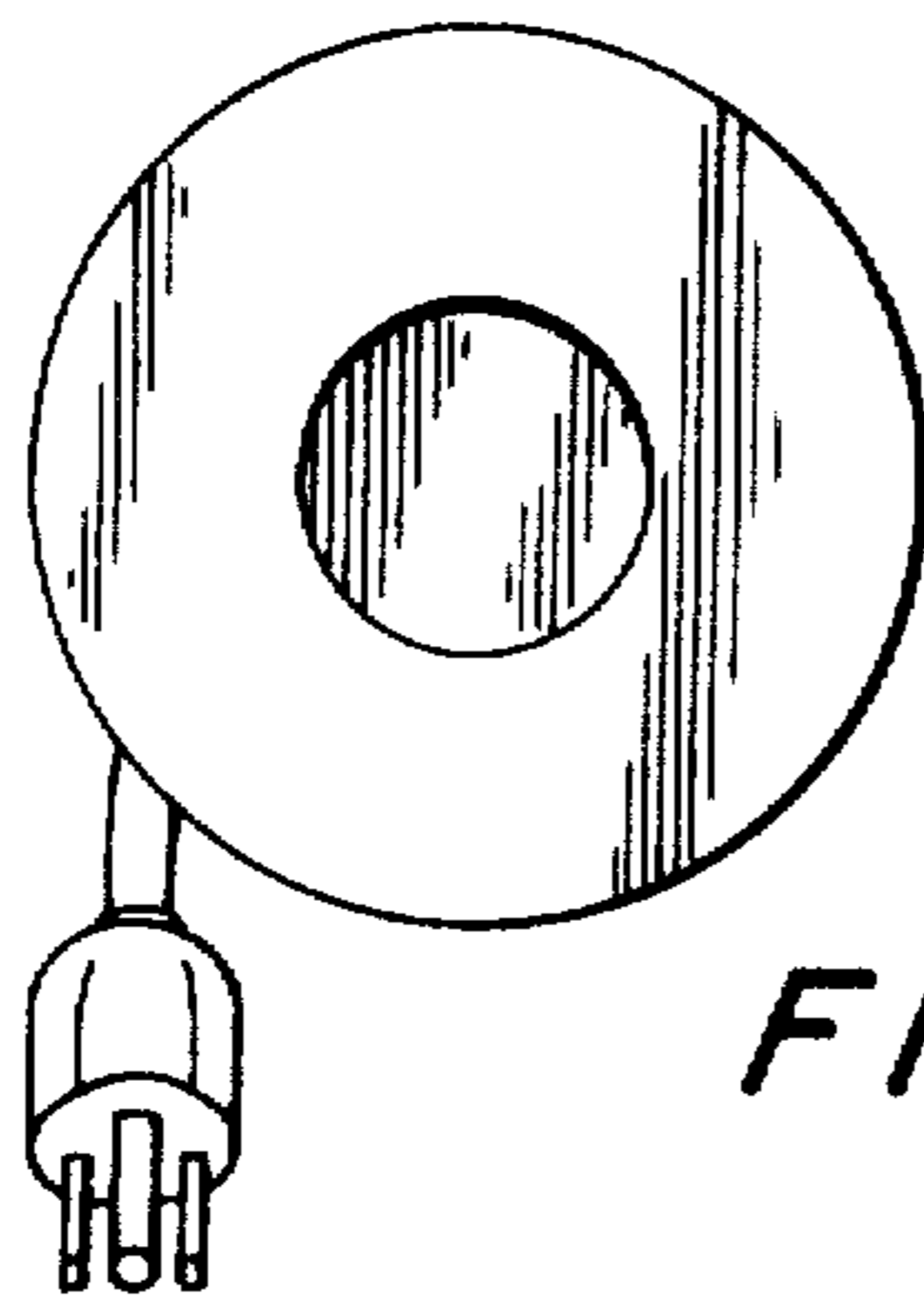

FIG. 5