

[54] COMBINED FUEL INJECTOR AND THERMAL HEATER

[75] Inventor: Monte M. Dilliner, Lineville, Iowa

[73] Assignees: Oscar E. Jones; Ted Lowe, both of Des Moines, Iowa; Robert H. Robinson, Fairfield, Ill. ; a part interest

[**] Term: 14 Years

[21] Appl. No.: 270,230

[22] Filed: Jun. 4, 1981

[52] U.S. Cl. D15/05; D23/77

[58] Field of Search D23/72, 77; 123/445, 123/446, 504, 505; 417/269, 534, 539; 239/533.2-533.12, 584; D13/16, 15; D15/1, 5

[56] References Cited

U.S. PATENT DOCUMENTS

1,445,100 2/1923 Nelson 123/505 X

2,114,565	4/1938	Kovach	417/539	X
2,148,112	2/1939	Dillstrom	123/504	X
3,233,554	2/1966	Huber et al.	417/534	X
3,361,077	1/1968	Freeman	417/269	
3,507,262	4/1970	Stage	123/504	
3,816,029	6/1974	Bowen et al.	417/223	

Primary Examiner—Catherine E. Kemper
Attorney, Agent, or Firm—Morton S. Adler

[57] CLAIM

The ornamental design for a combined fuel injector and thermal heater, as shown and described.

DESCRIPTION

FIG. 1 is a perspective view of a combined fuel injector and thermal heater showing my new design, FIG. 2 is an end view thereof viewed from the right of FIG. 1, FIG. 3 is an end view thereof viewed from the left of FIG. 1, and FIG. 4 is a perspective view of a second embodiment of a combined fuel injector and thermal heater.

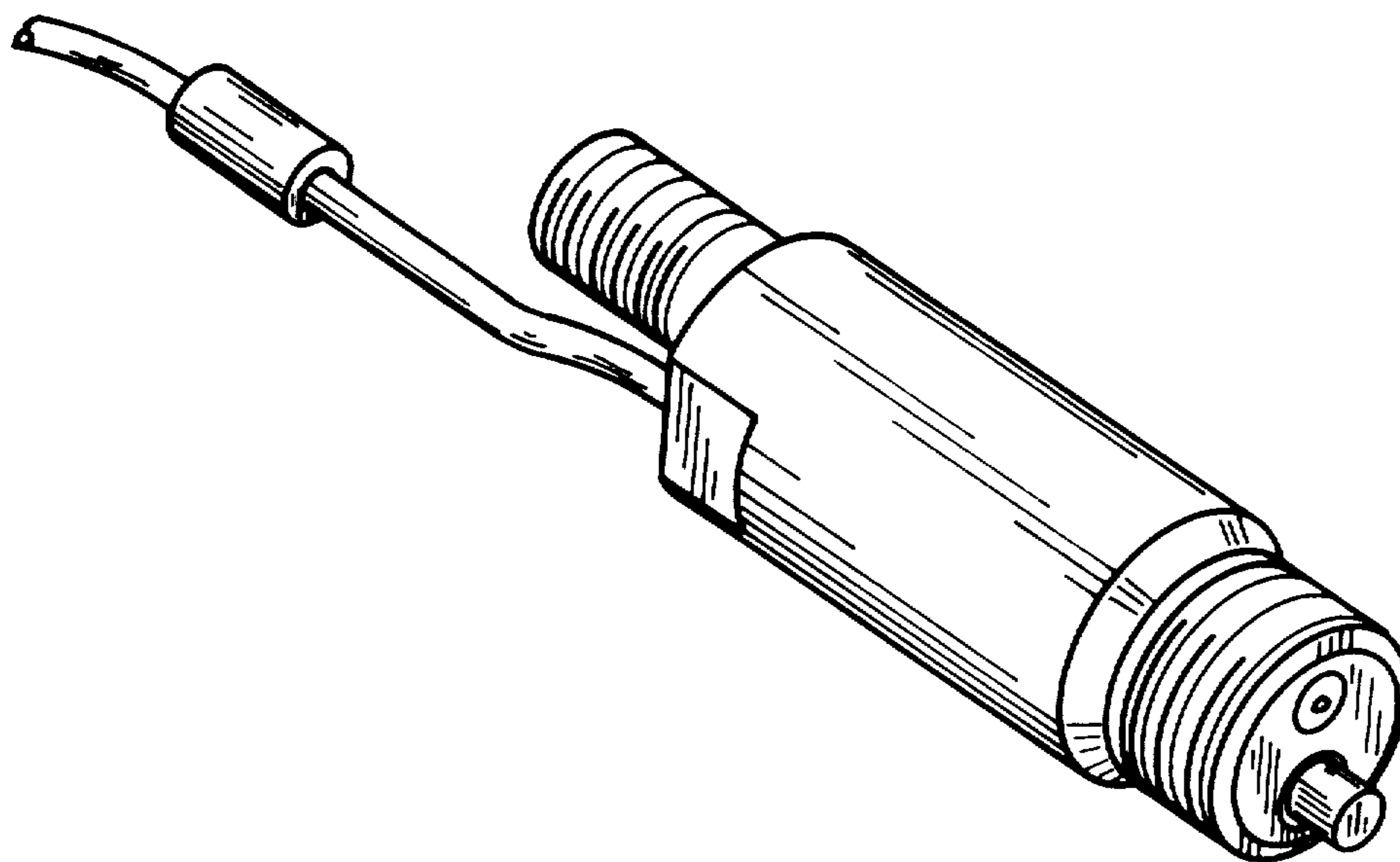

FIG. 1

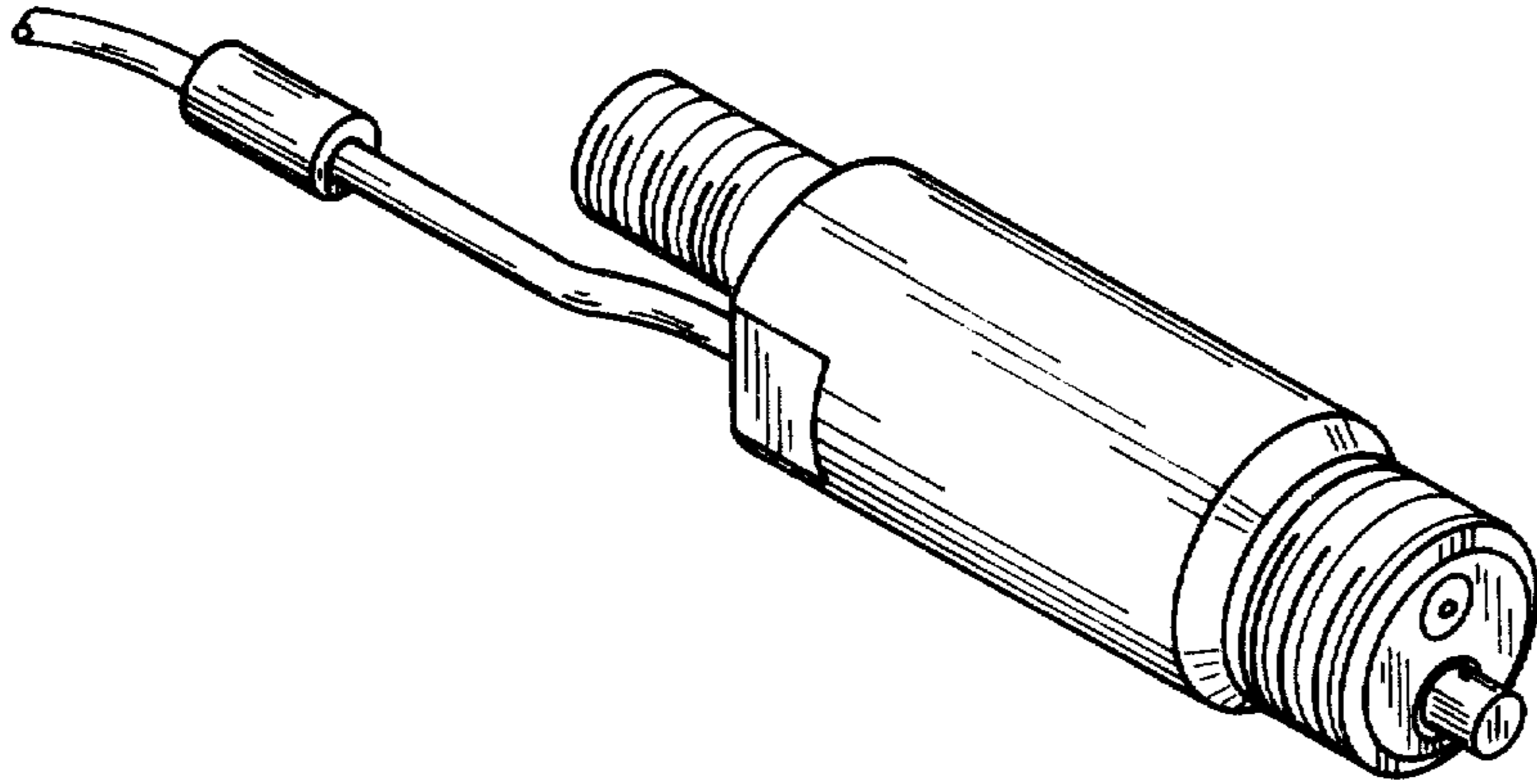

FIG. 4

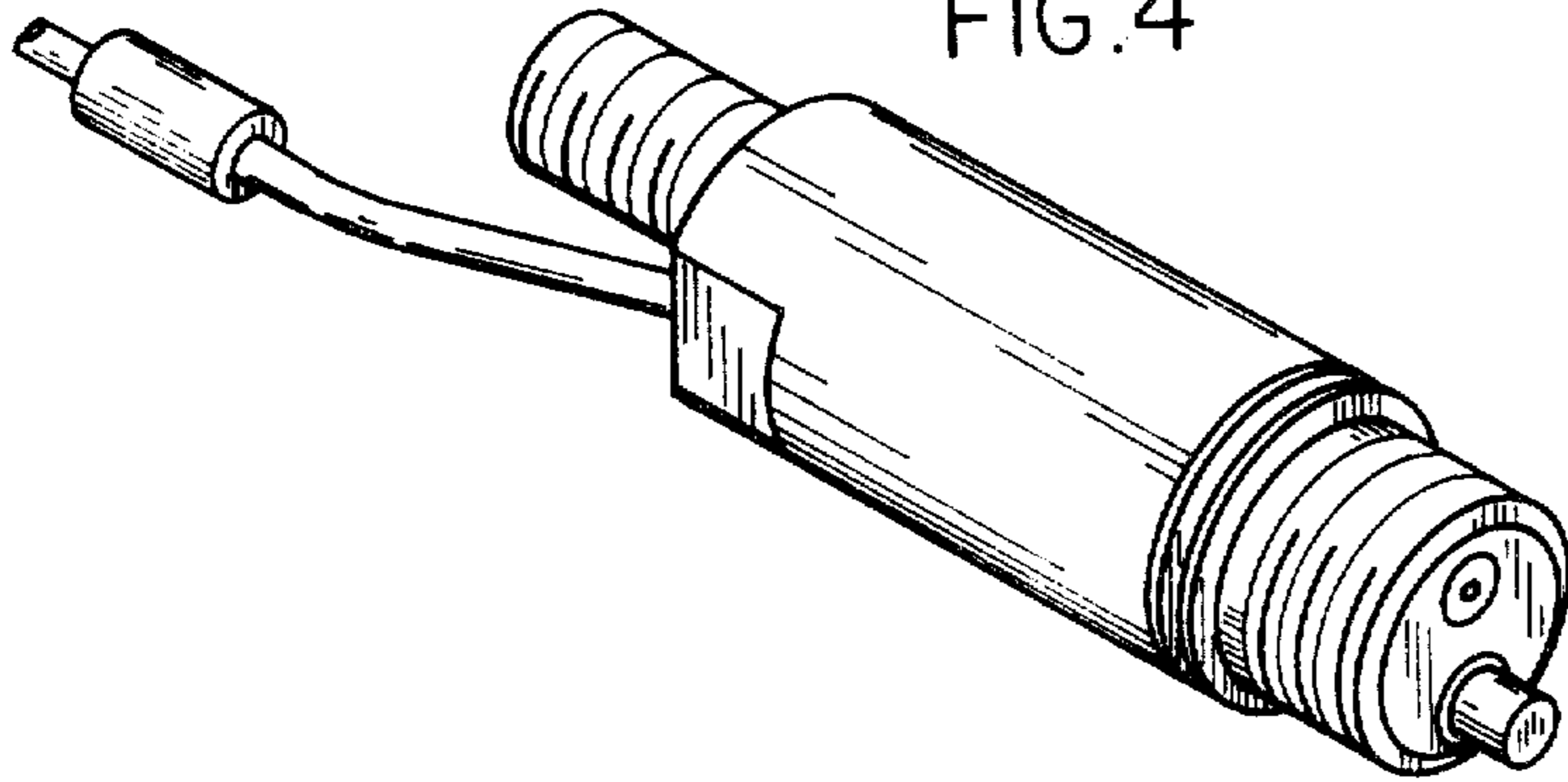

FIG. 2

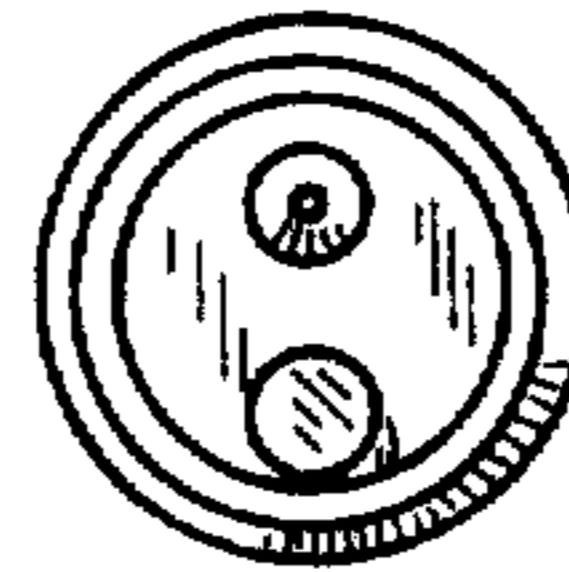

FIG. 3

