

[54] HANDLE STUD FOR AN ARTICLE OF LUGGAGE OR THE LIKE

[75] Inventor: Edward M. Stolarz, Yorktown Heights, N.Y.

[73] Assignee: Presto Lock, Inc., Garfield, N.J.

[**] Term: 14 Years

[21] Appl. No.: 502,249

[22] Filed: Jun. 8, 1983

Related U.S. Application Data

[62] Division of Ser. No. 233,637, Feb. 12, 1981.

[52] U.S. Cl. D8/321; D8/306

[58] Field of Search D8/300, 306, 315, 318, D8/321; 190/57, 58 R, 58 A, 58 B

[56] References Cited

U.S. PATENT DOCUMENTS

D. 124,803	1/1941	Levine	D8/306
D. 171,984	4/1954	Levine	D8/321
D. 186,753	11/1959	Gehrie	D8/321
D. 188,405	7/1960	Levine	D8/306
2,613,771	10/1952	Levine	190/58 R
2,806,564	9/1957	Pick et al.	190/58 R
3,107,761	10/1963	Storey	190/58 R

OTHER PUBLICATIONS

Presto Lock Catalog Index ©1978; table of contents page; Handle Stud.

Primary Examiner—B. J. Bullock

Attorney, Agent, or Firm—Shapiro and Shapiro

[57] CLAIM

The ornamental design for a handle stud for an article, of luggage or the like, as shown and described.

DESCRIPTION

This application is a division of Ser. No. 233,637, filed Feb. 12, 1981.

FIG. 1 is a perspective view of a handle stud for an article of luggage or the like embodying my new design; the broken line showing of the attaching means is for illustration purposes only;

FIG. 2 is a front elevational view thereof;

FIG. 3 is a side elevational view taken from the left side of FIG. 1, the appearance of the opposite side being the same;

FIG. 4 is a top plan view thereof;

FIG. 5 is a perspective view of a second embodiment of the design of FIG. 1, the broken line showing of the attaching means is for illustration purposes only;

FIG. 6 is a front elevational view of FIG. 5, the rear being the same;

FIG. 7 is a side elevational view taken from the left side of FIG. 5 the appearance of the opposite side being the same;

FIG. 8 is a top plan view of FIG. 5;

FIG. 9 is a perspective view of a third embodiment of the design of FIG. 1, the broken line showing of the attaching means is for illustration purposes only;

FIG. 10 is a front elevational view of FIG. 9, the rear being the same;

FIG. 11 is a side elevational view taken from the left side of FIG. 9;

FIG. 12 is a side elevational view taken from the right side of FIG. 9;

FIG. 13 is a top plan view of FIG. 9;

FIG. 14 is a perspective view of a fourth embodiment of the design of FIG. 1, the broken line showing of the attaching means is for illustration purposes only;

FIG. 15 is a front elevational view of FIG. 14, the rear being the same;

FIG. 16 is a side elevational view taken from the left side of FIG. 14;

FIG. 17 is a side elevational view taken from the right side of FIG. 14;

FIG. 18 is a top plan view of FIG. 14;

FIG. 19 is a perspective view of a fifth embodiment of the design of FIG. 1;

FIG. 20 is a front elevational view of FIG. 19, the rear being the same and the broken line showing of the attaching means is for illustration purposes only;

FIG. 21 is a side elevational view taken from the left side of FIG. 19, the view from the right side being the same; the broken line showing of the attaching means is for illustration purposes only; and

FIG. 22 is a top plan view of FIG. 19.

The bottom of each embodiment is unadorned.

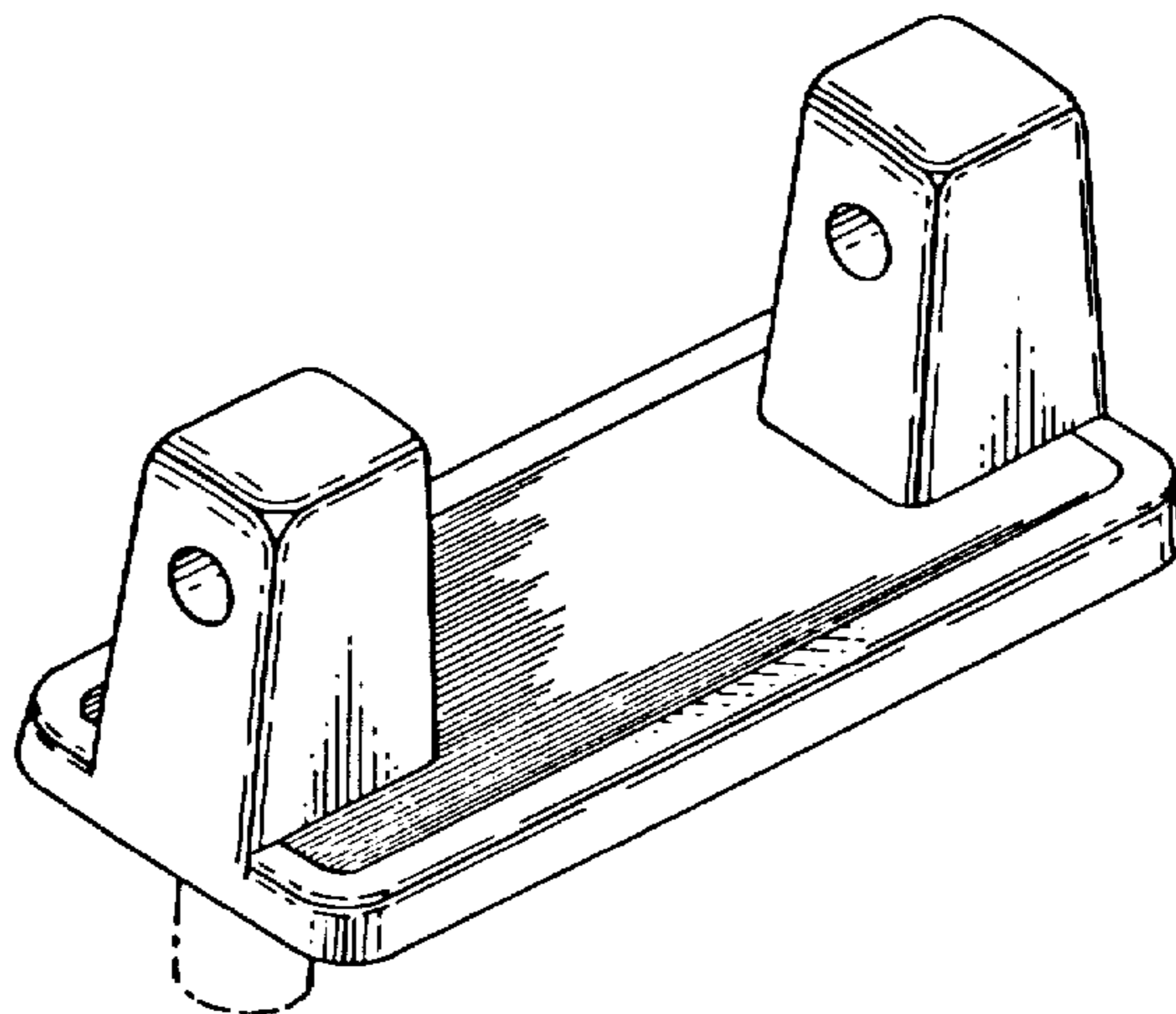

Fig. 1

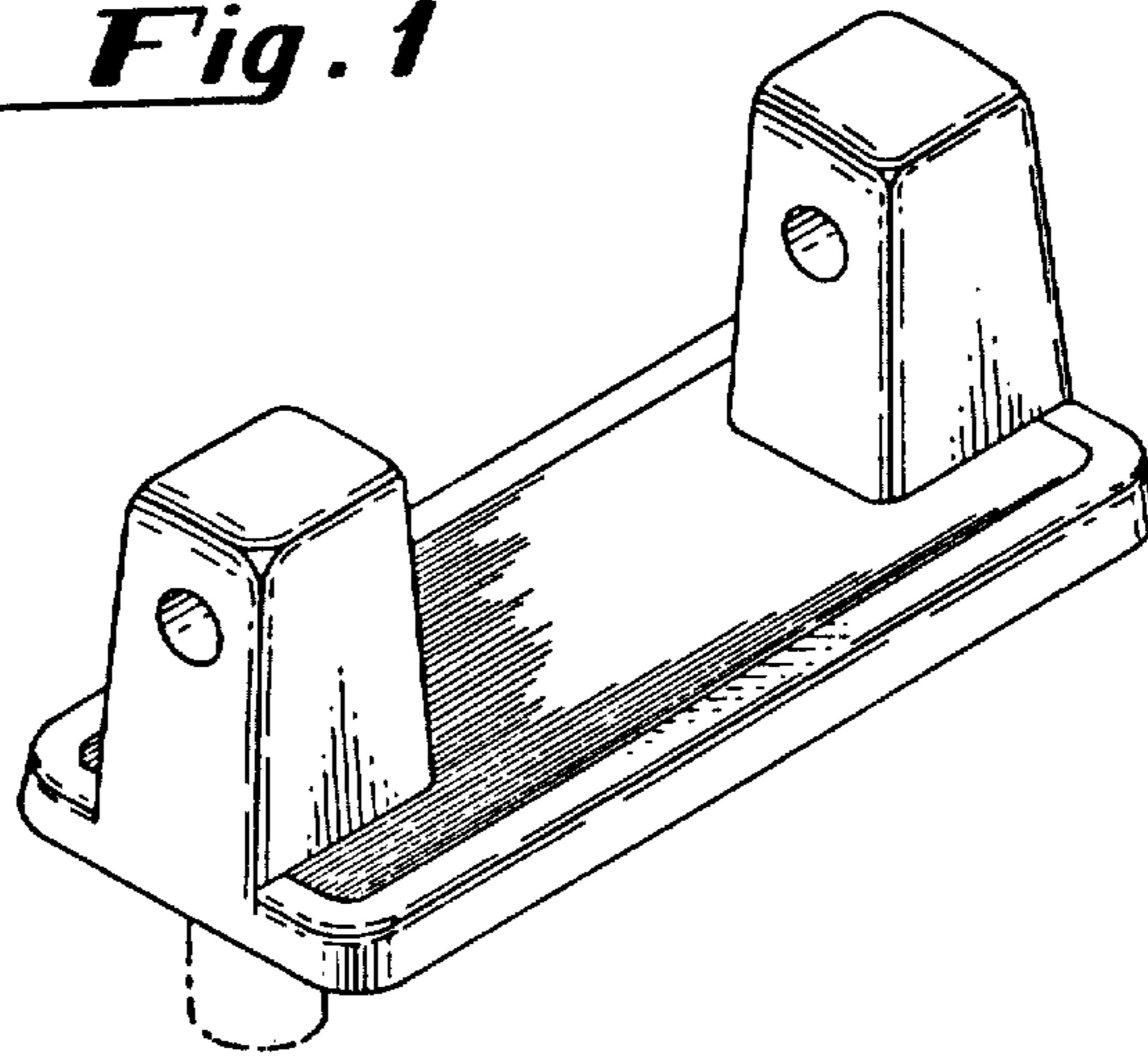

Fig. 2

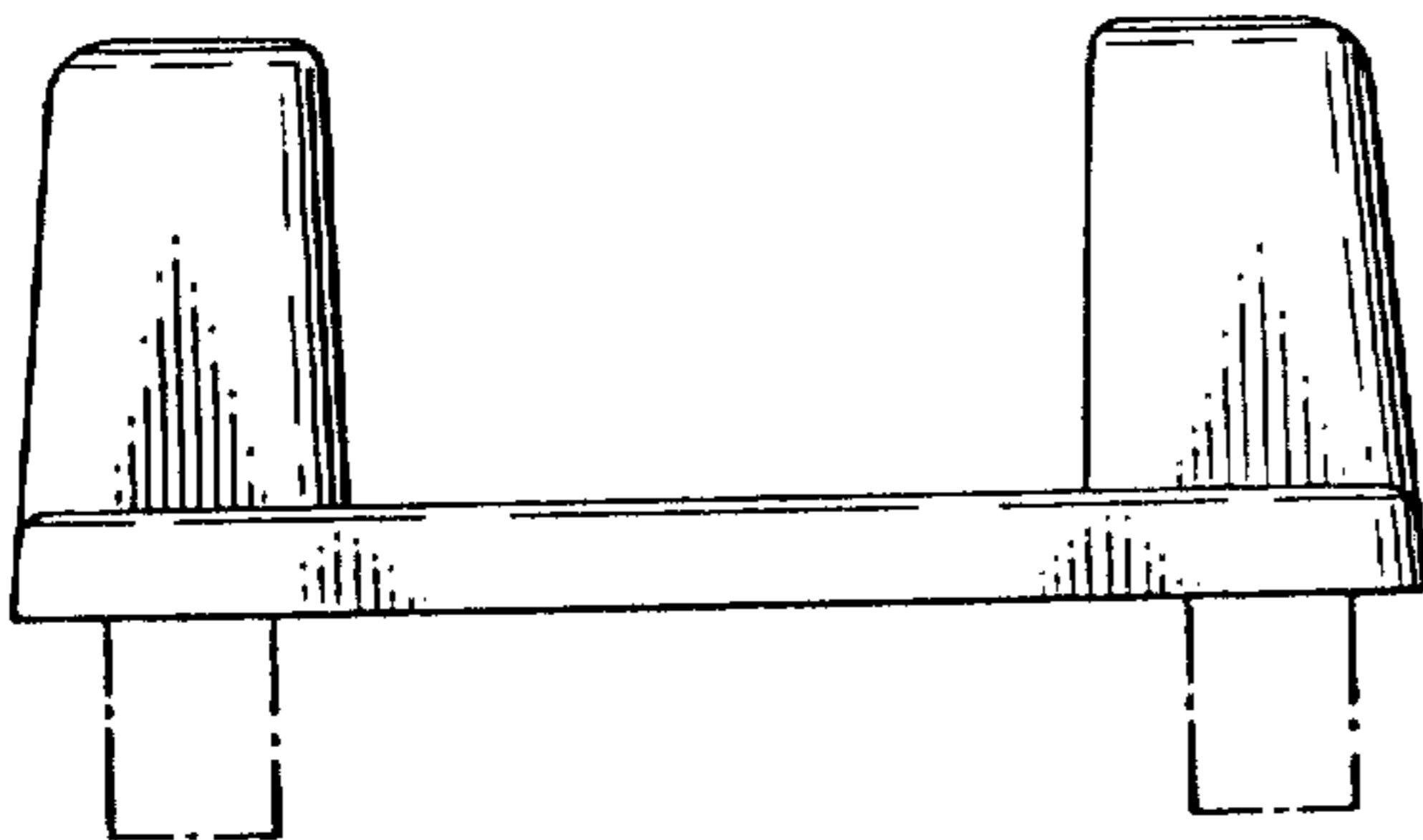

Fig. 3

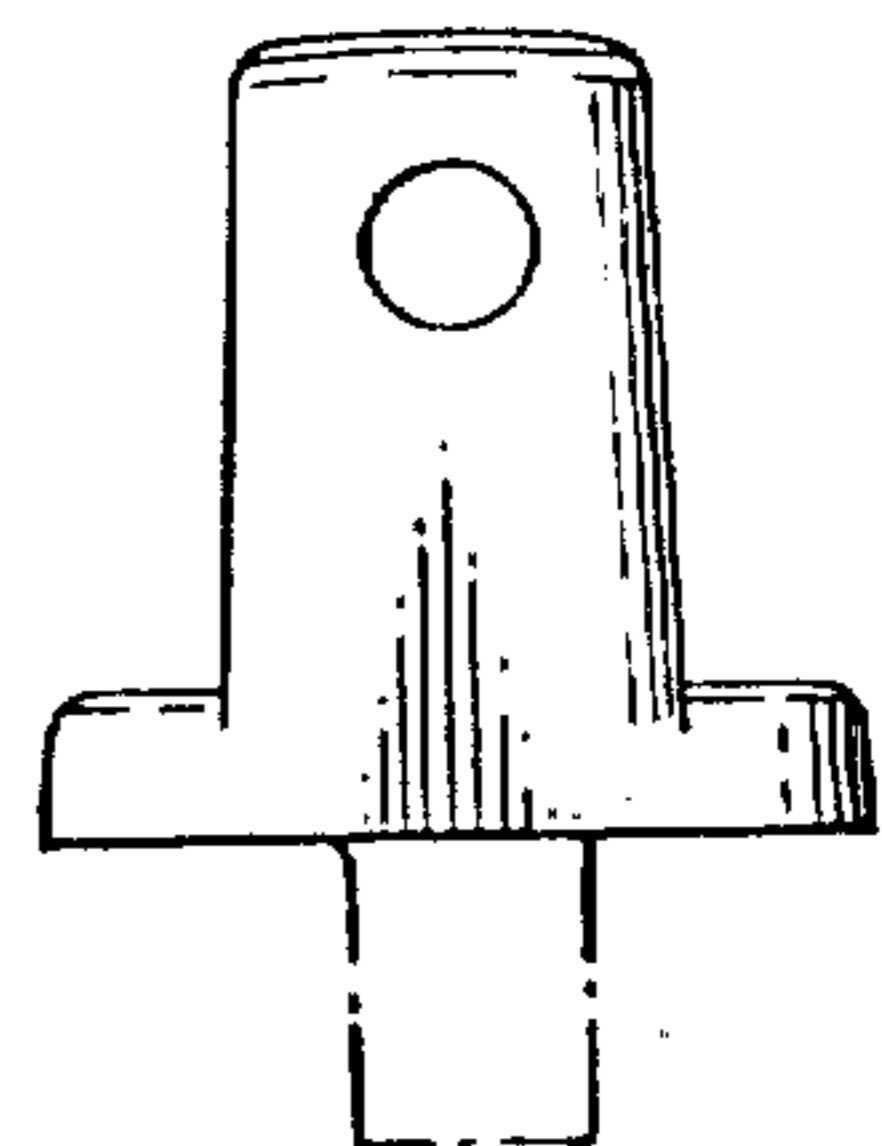

Fig. 4

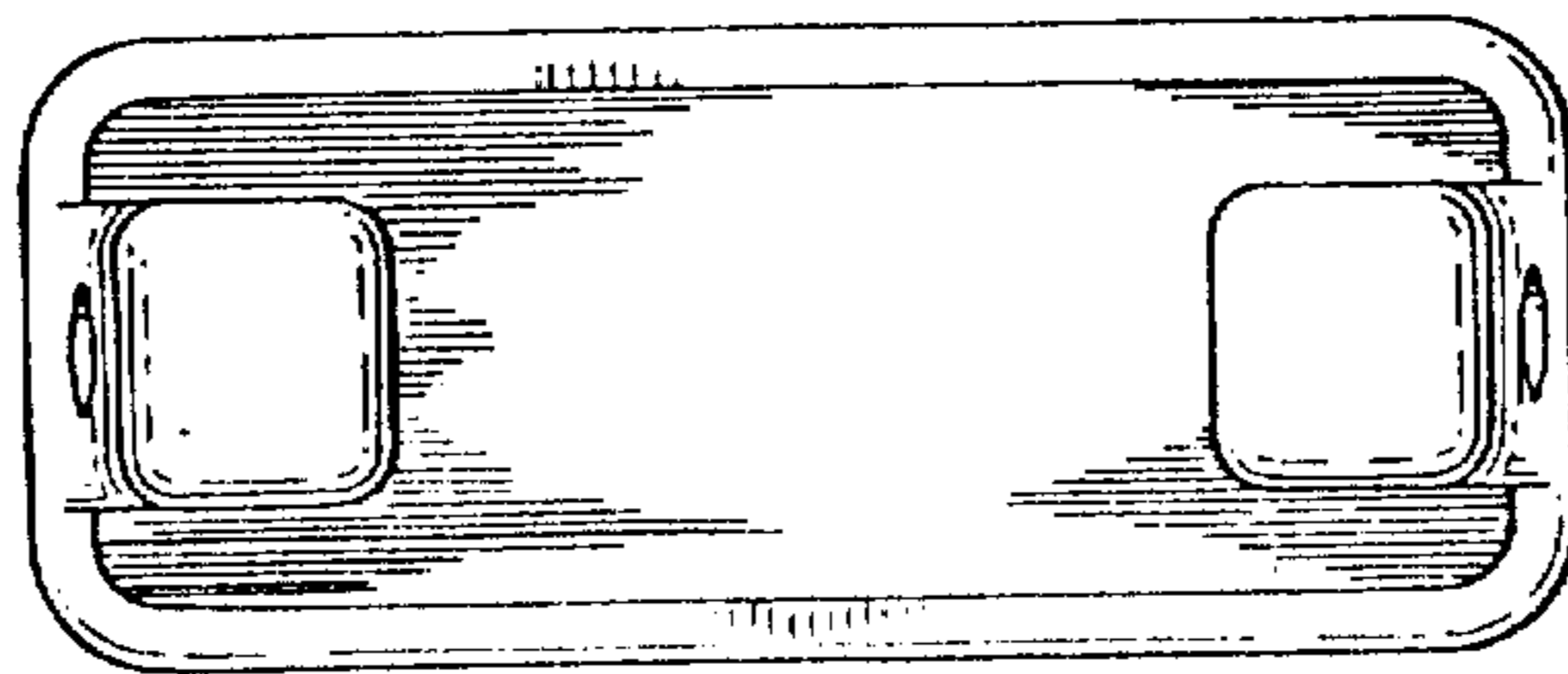

Fig. 5

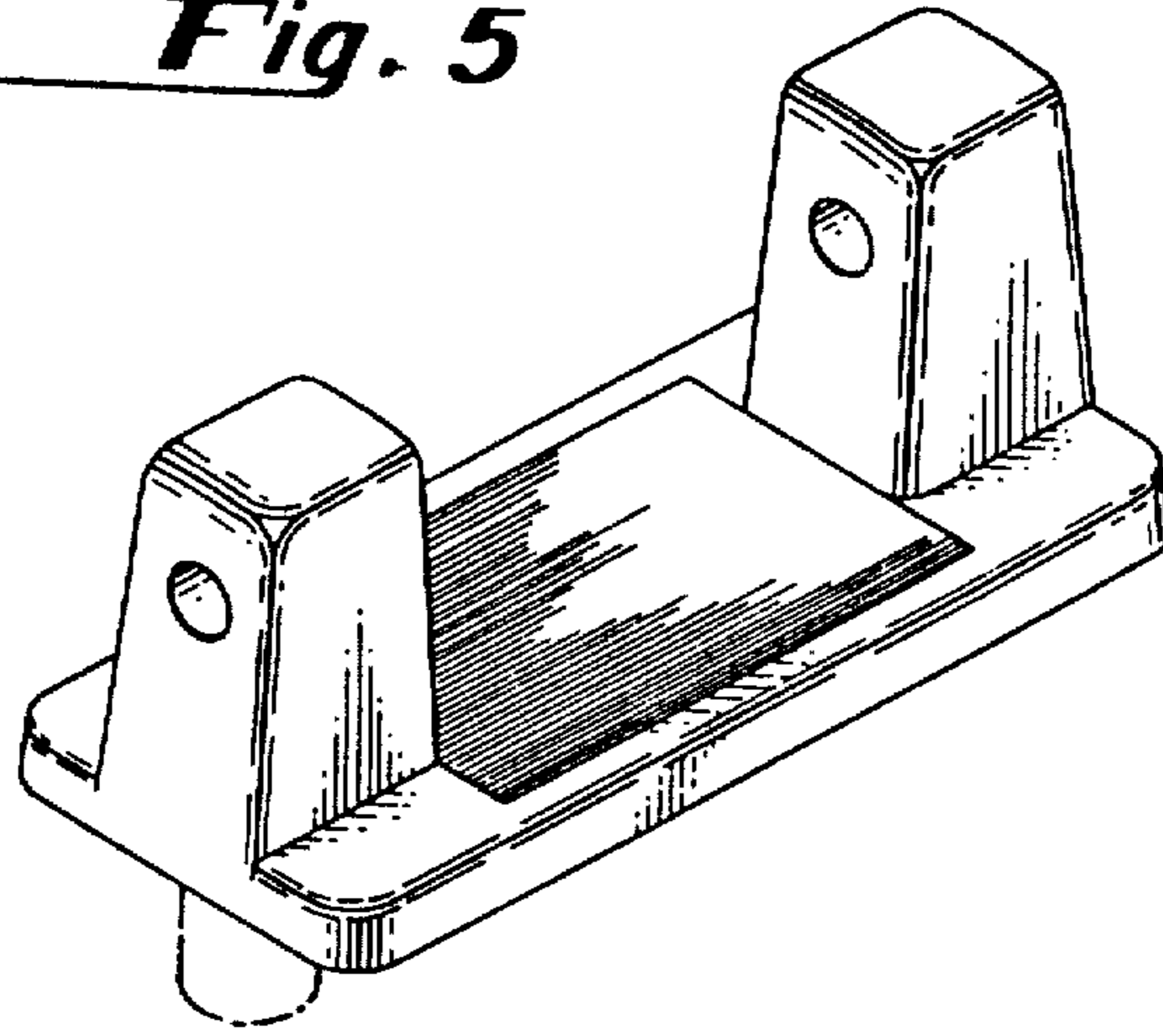

Fig. 6

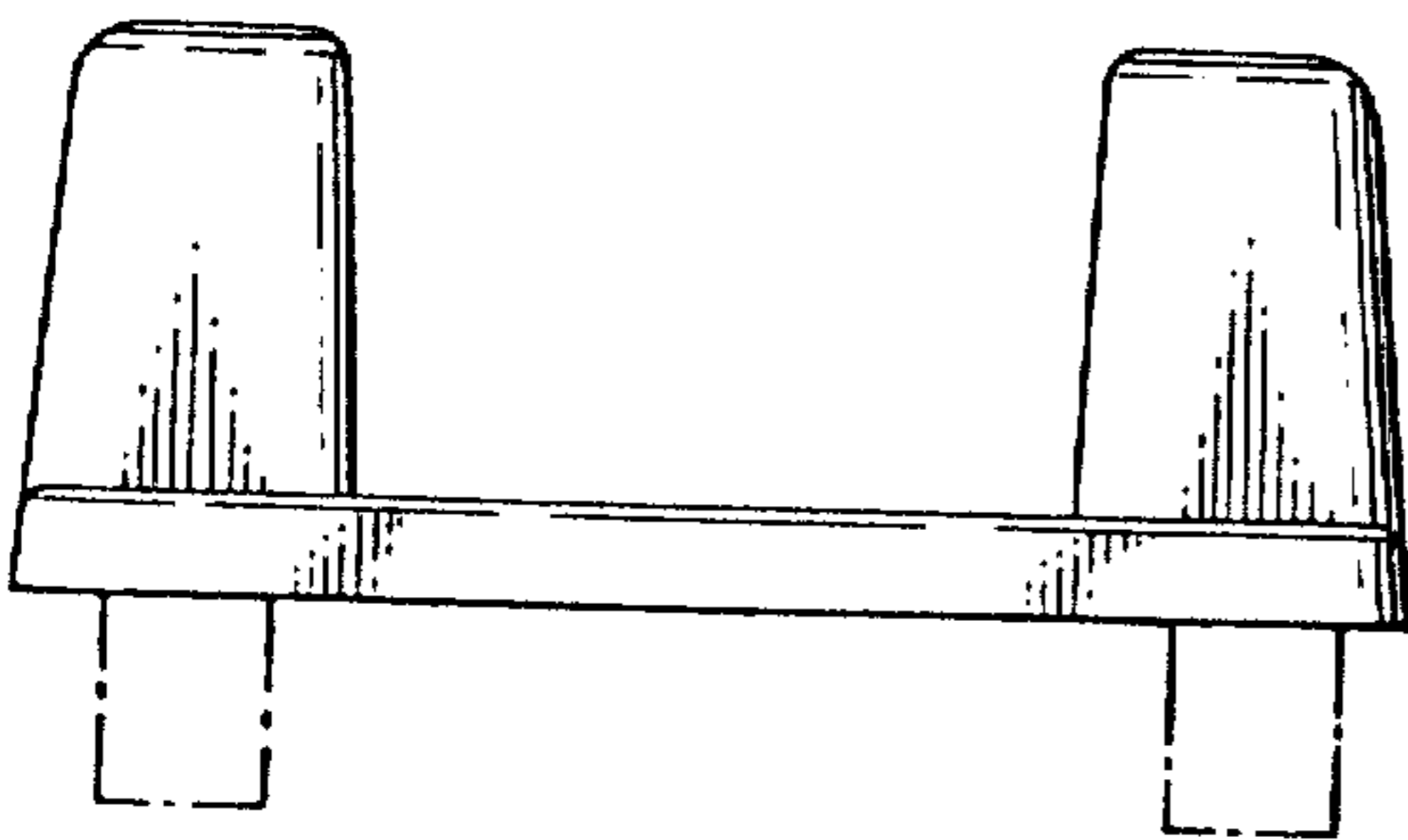

Fig. 7

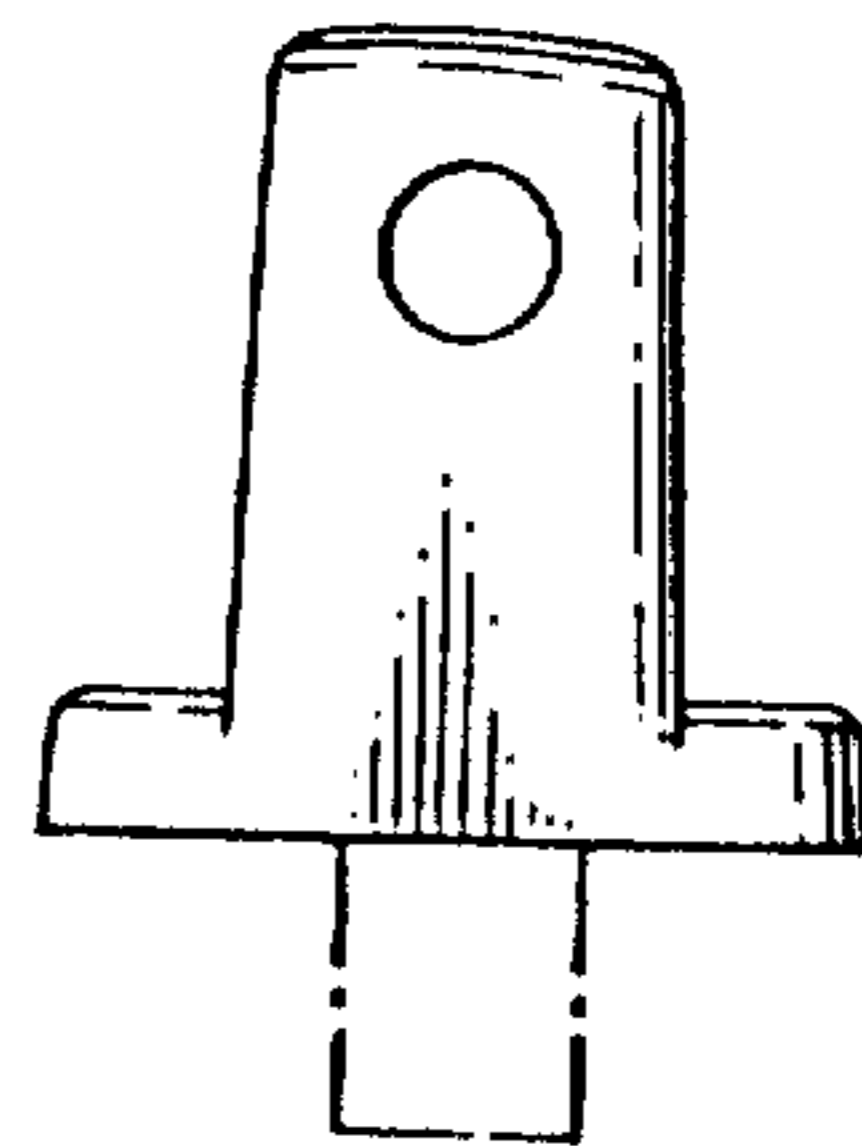

Fig. 8

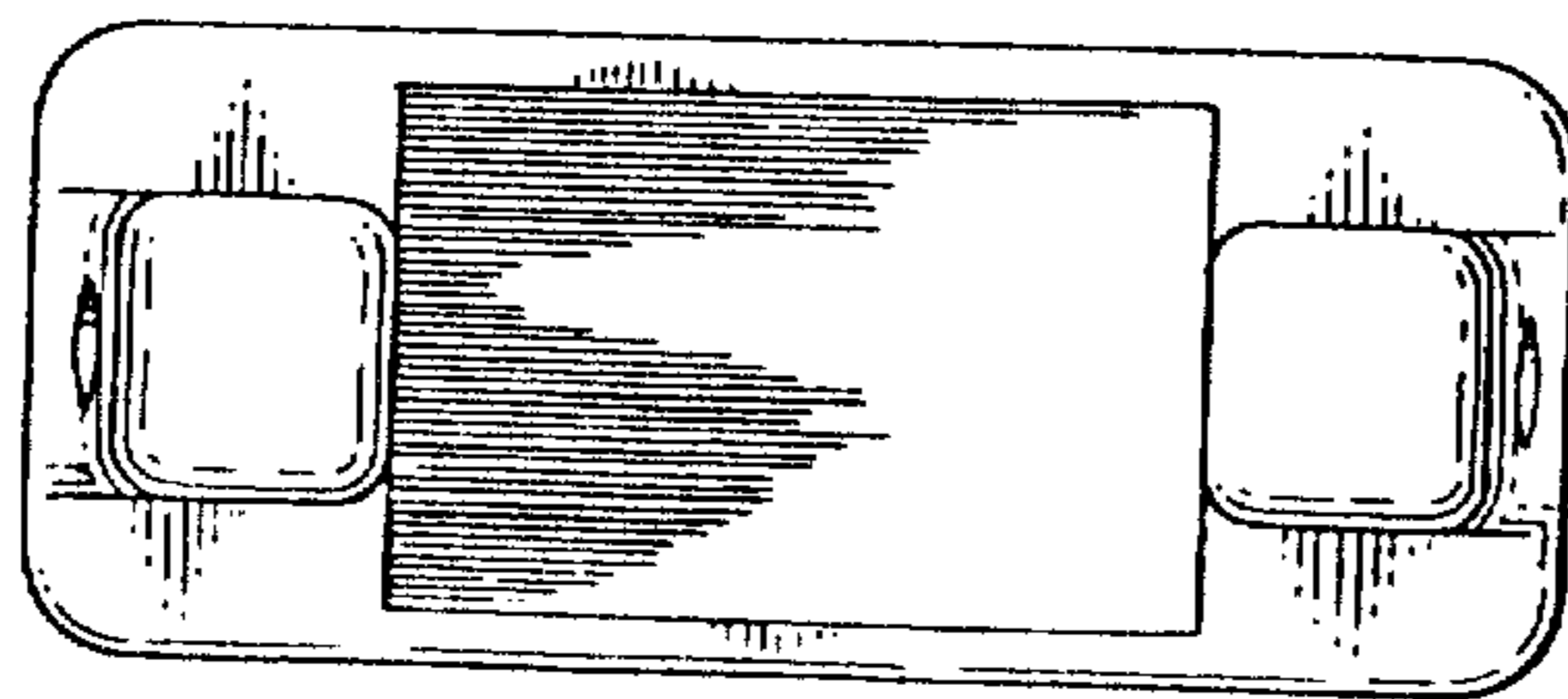

Fig. 9

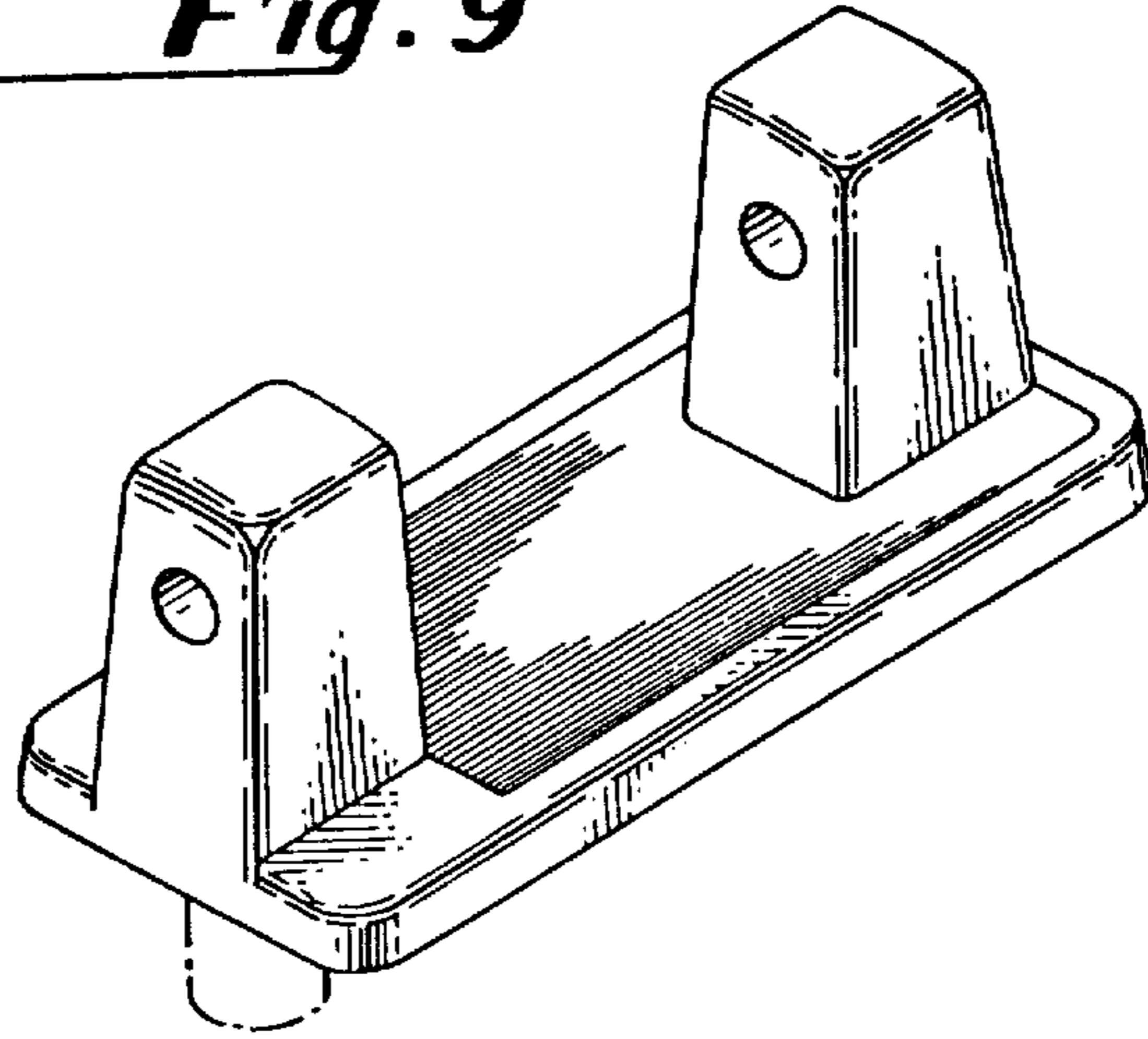

Fig. 10

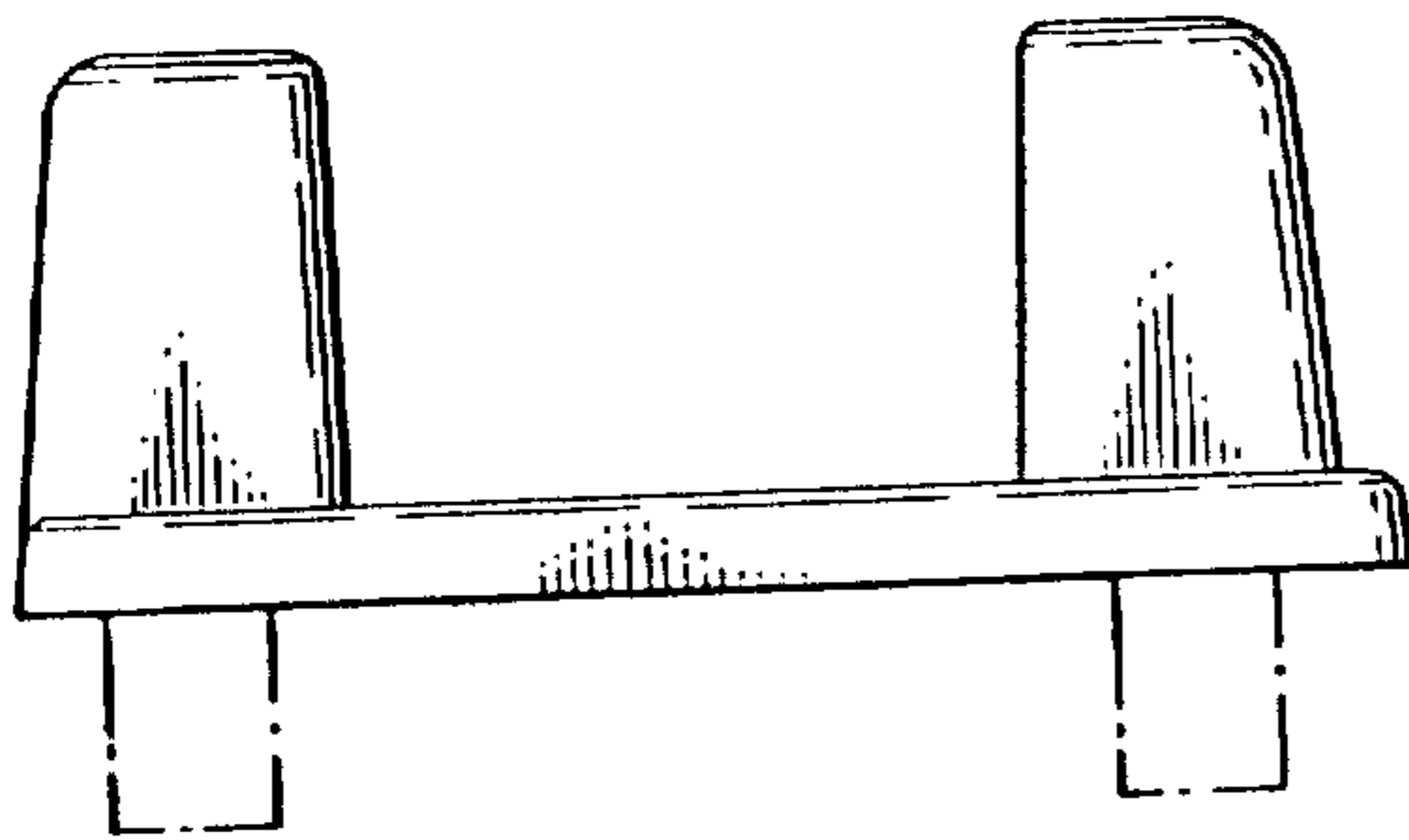

Fig. 11

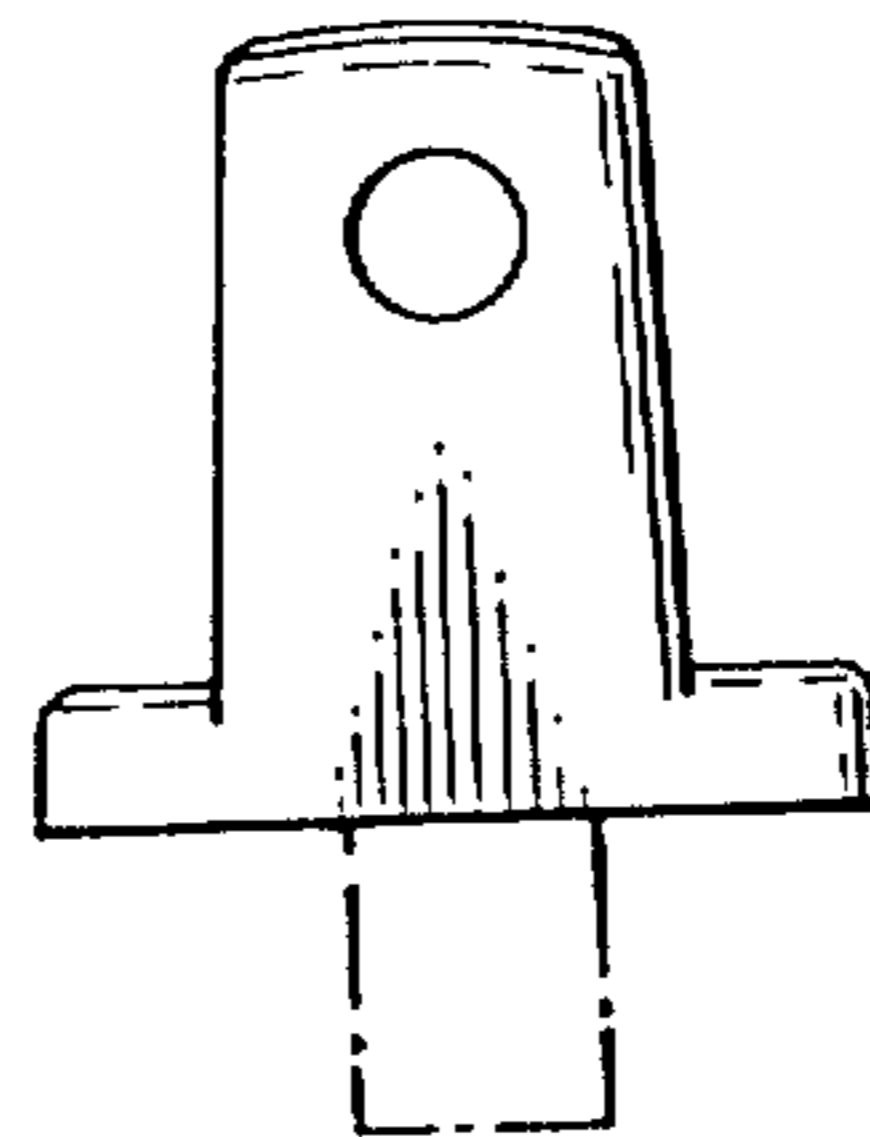

Fig. 12

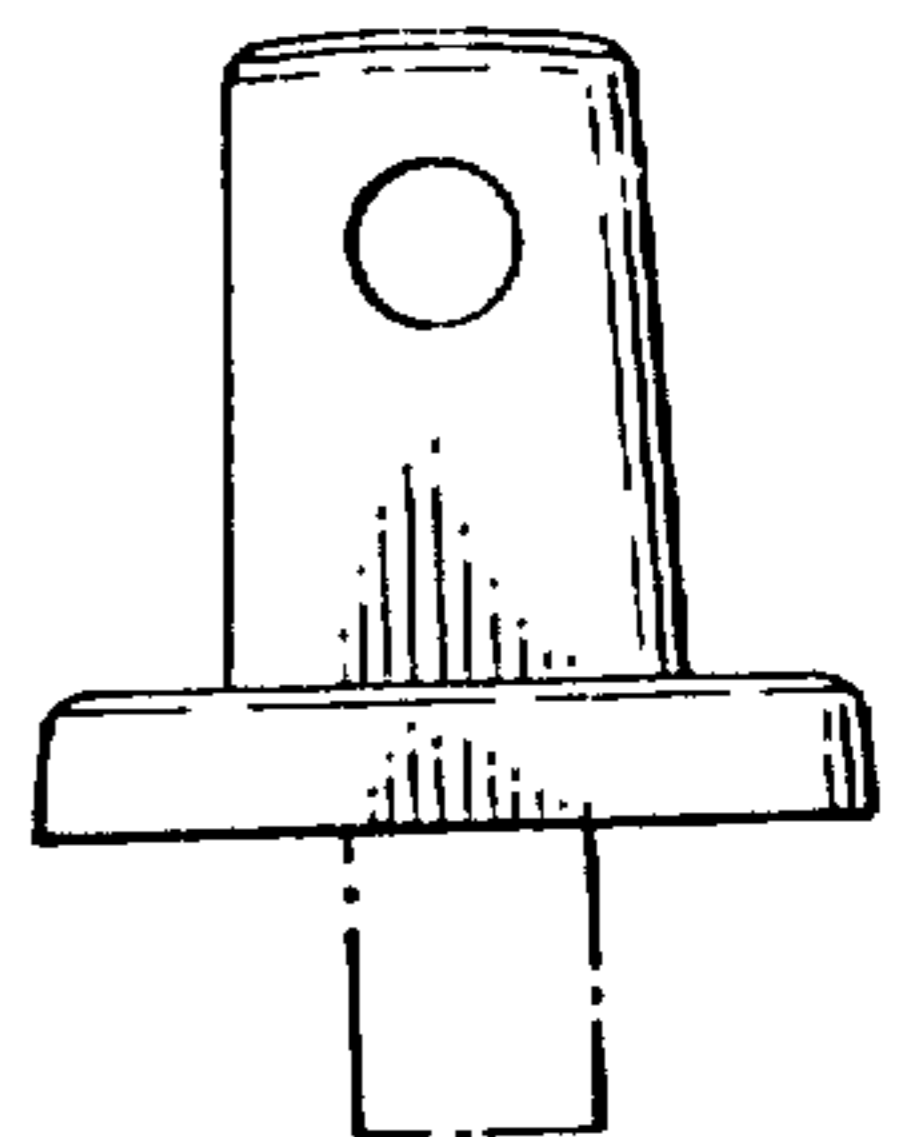

Fig. 13

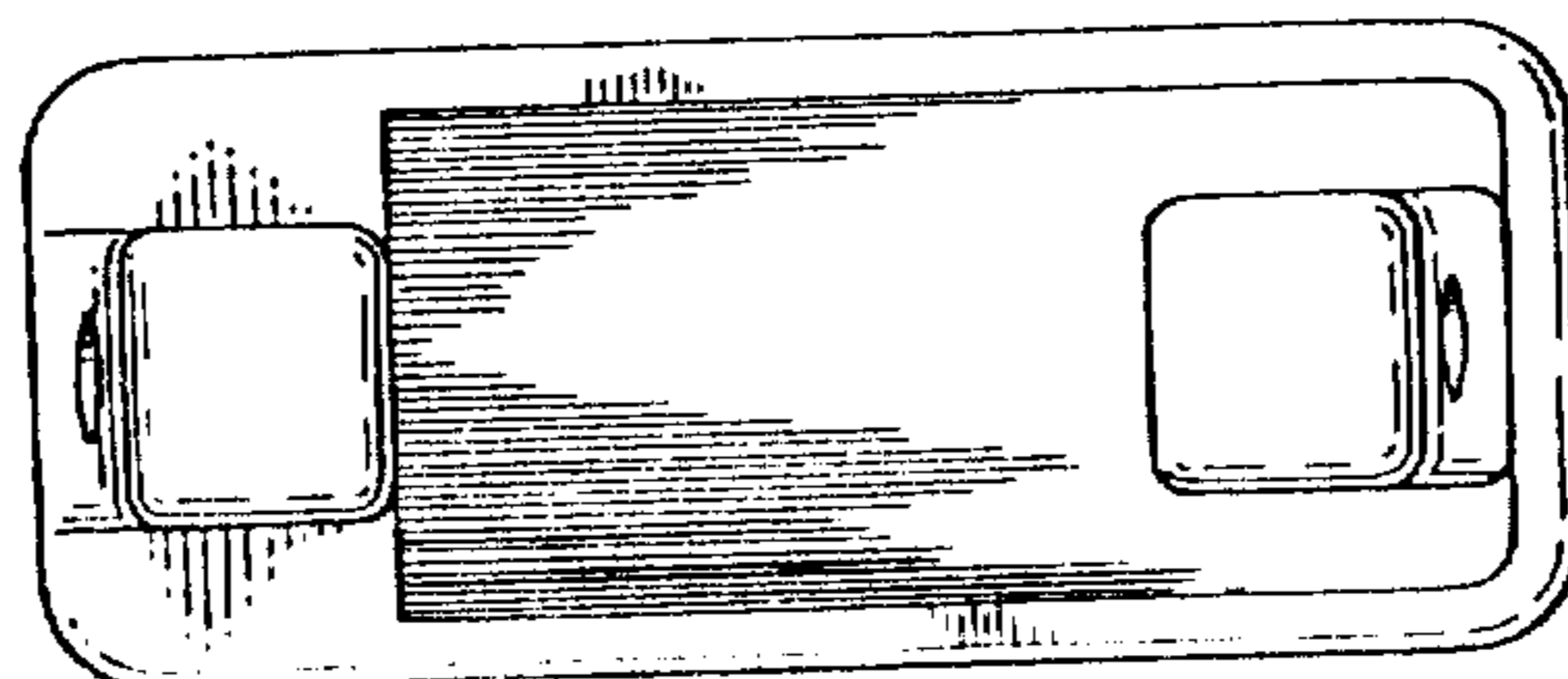

Fig. 14

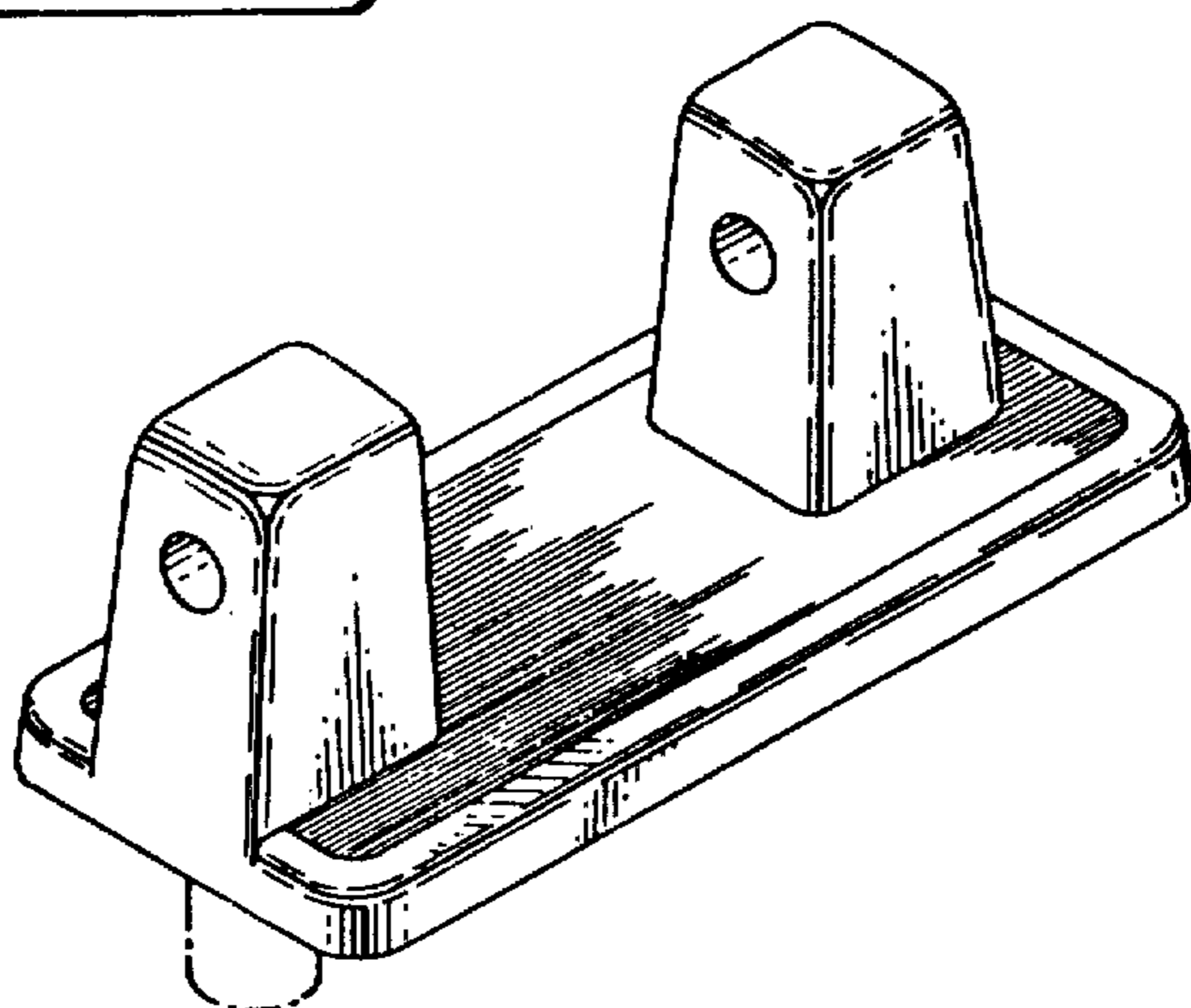

Fig. 15

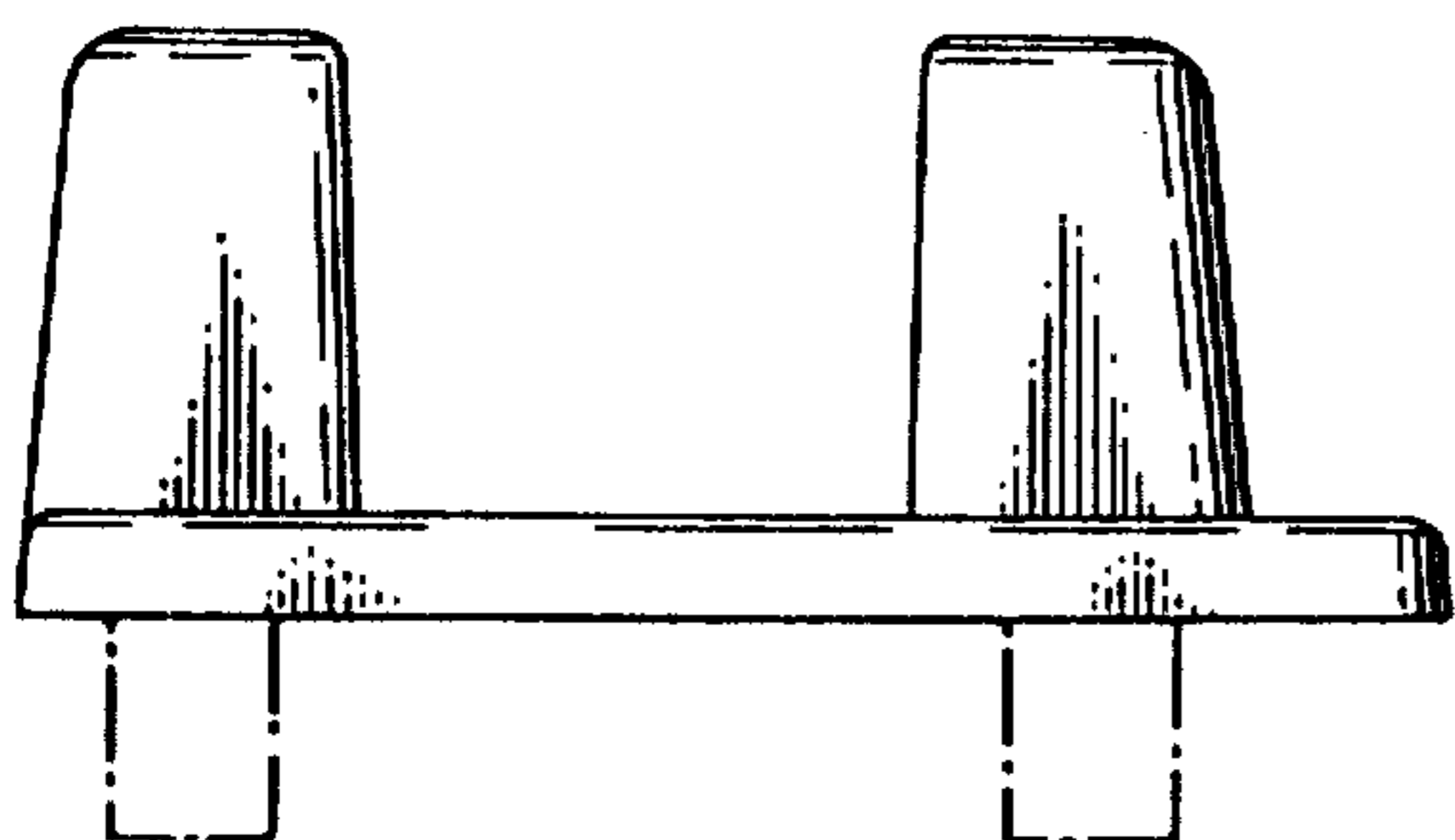

Fig. 16

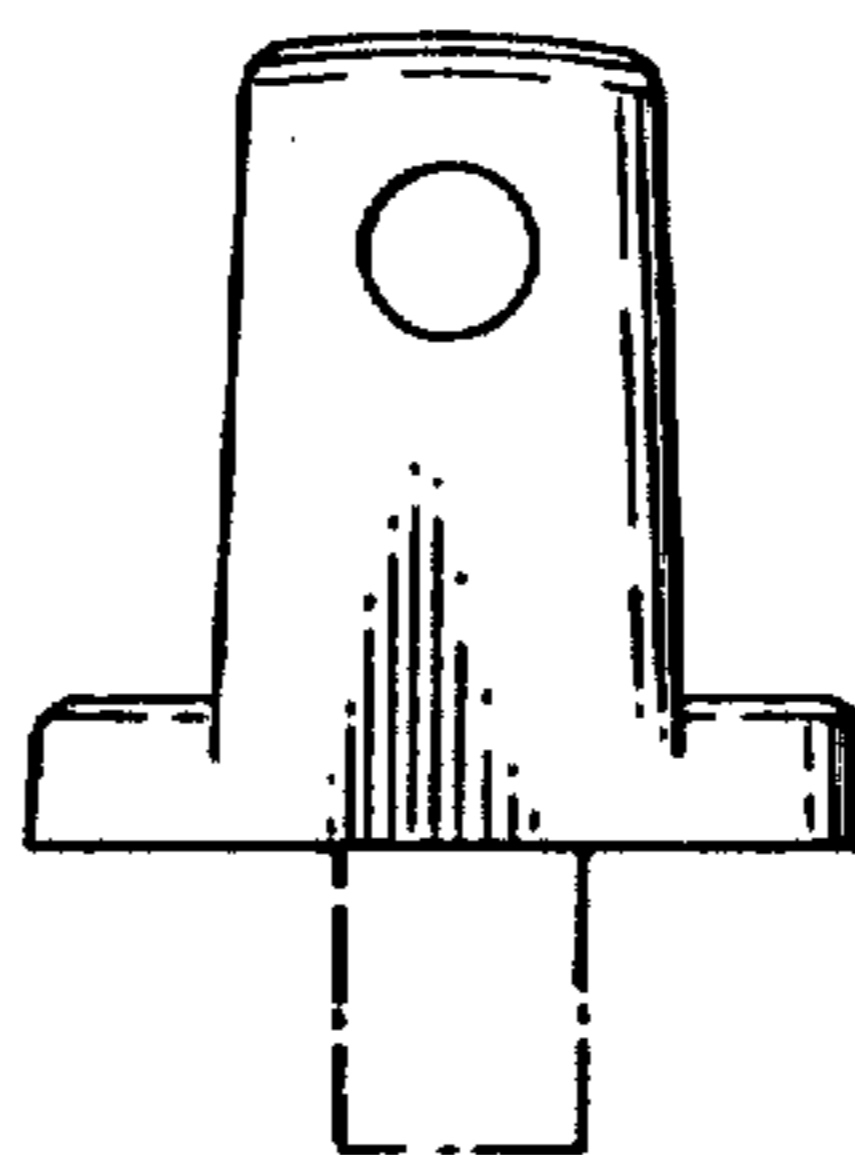

Fig. 17

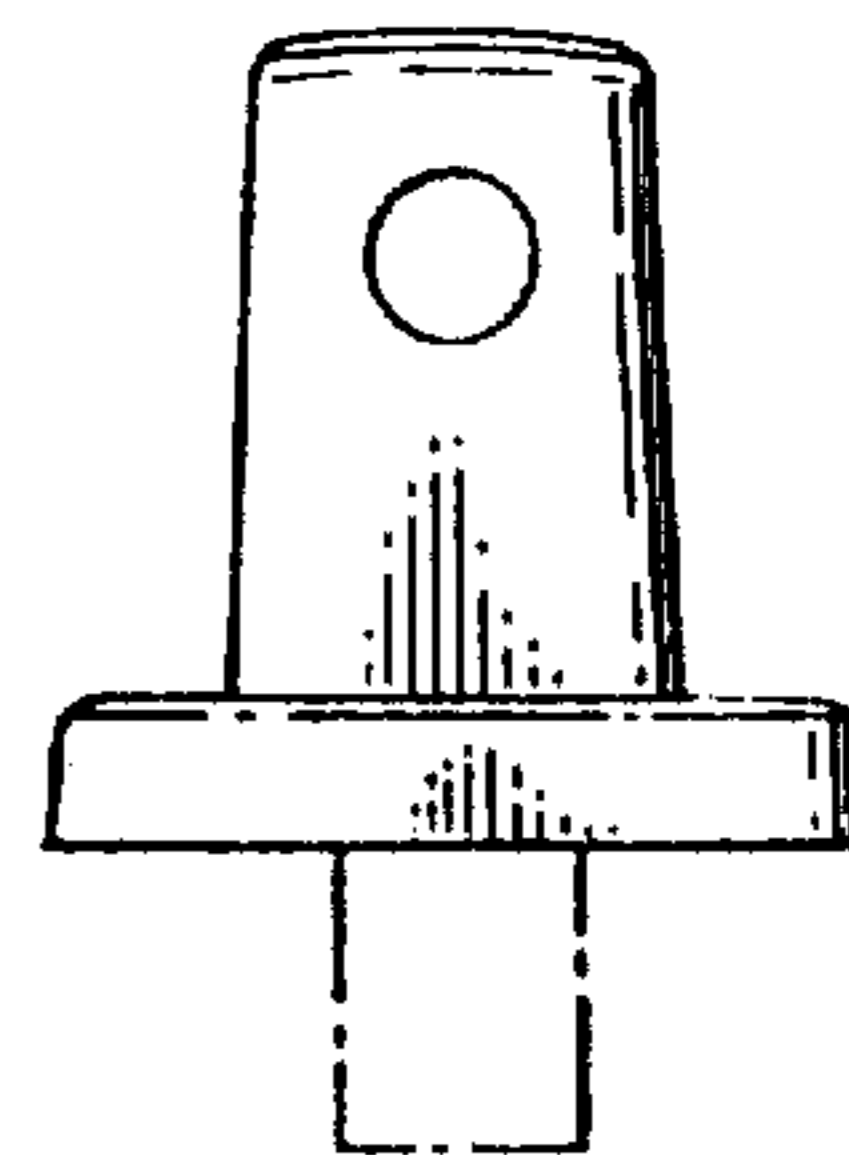

Fig. 18

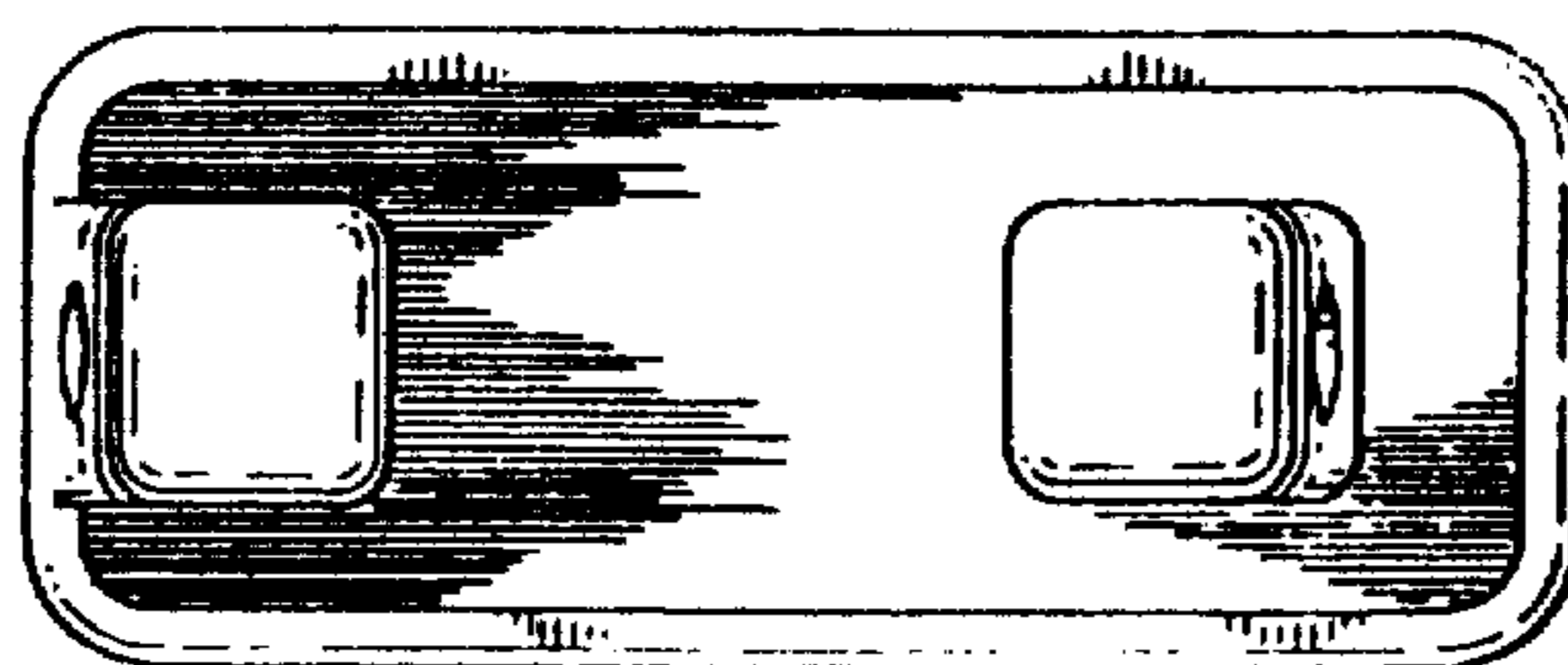

Fig. 19

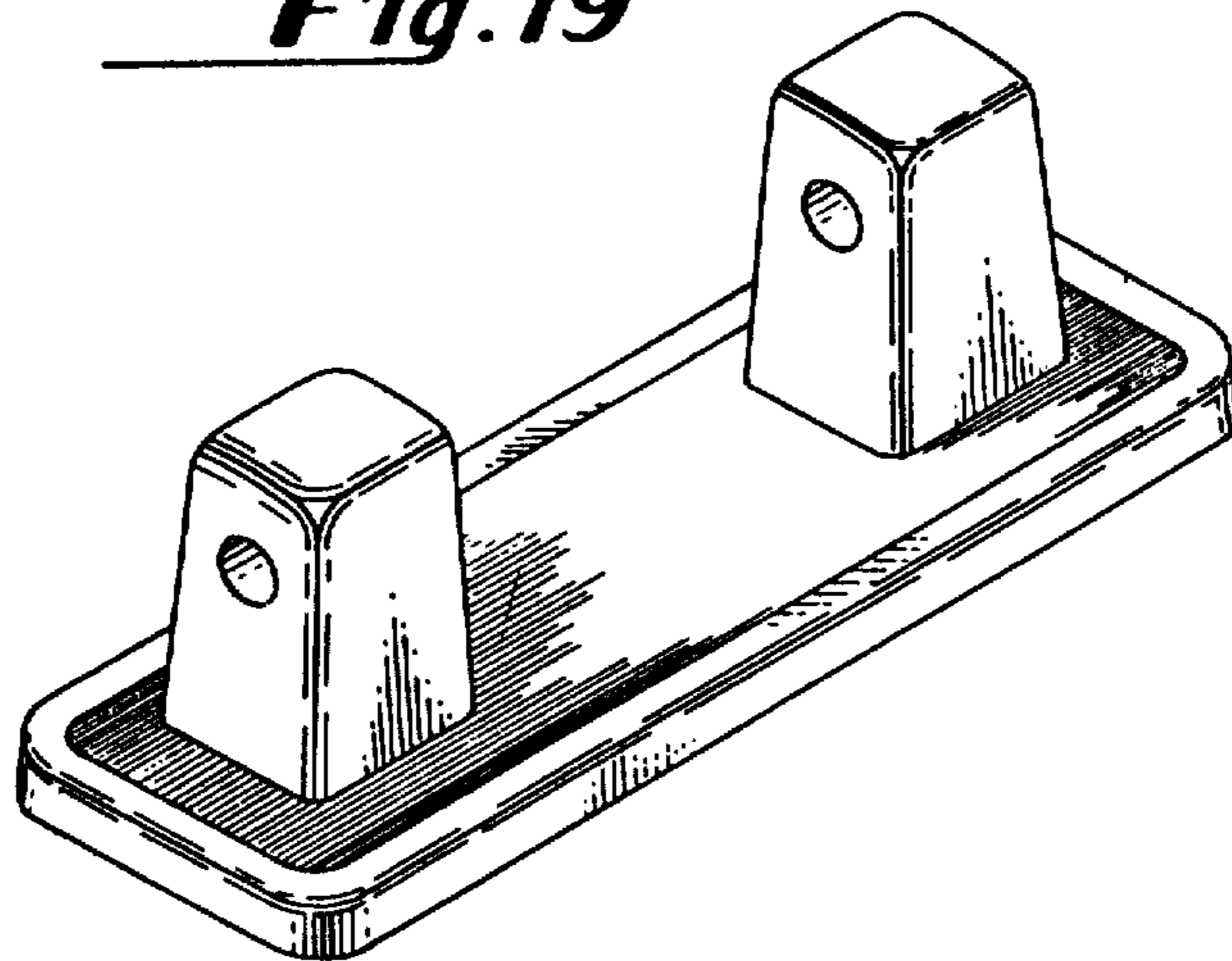

Fig. 20

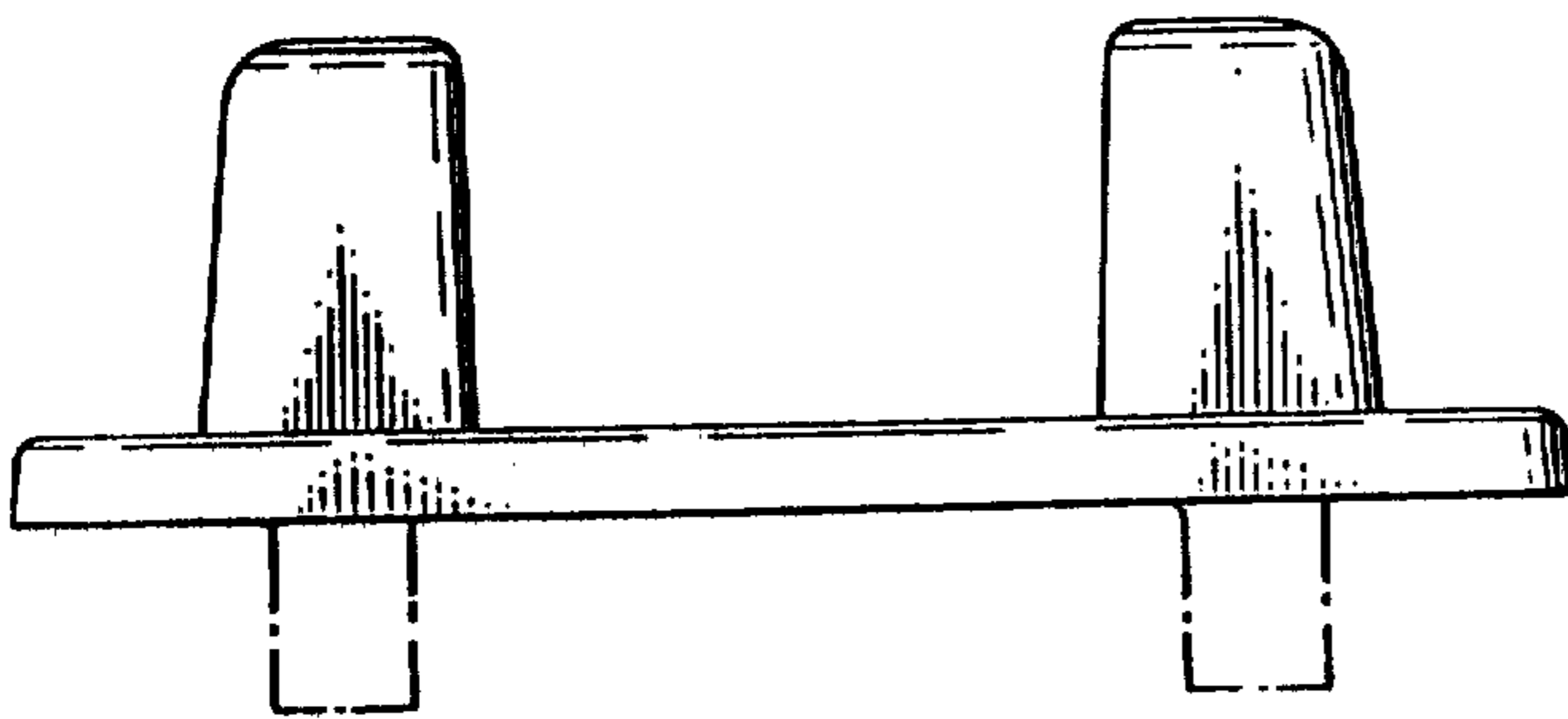

Fig. 21

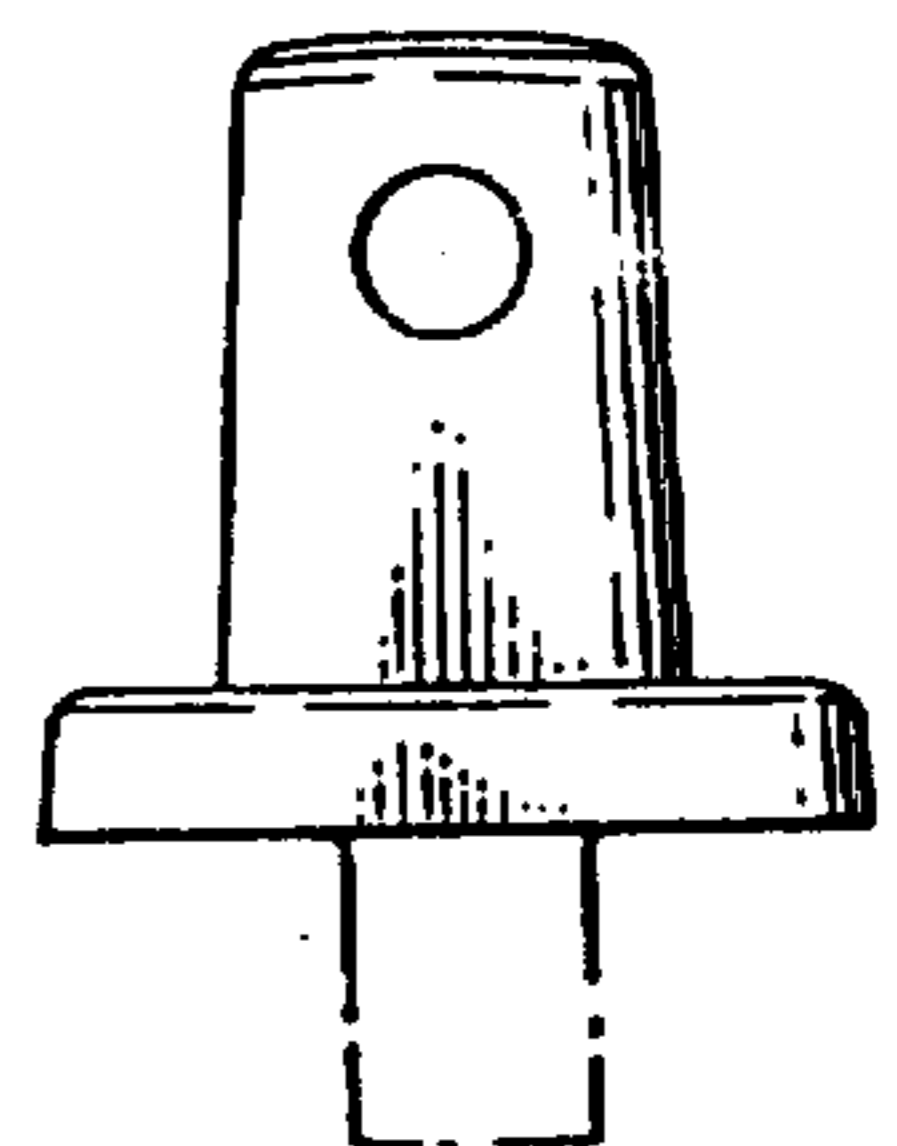

Fig. 22

