

[54] **MOTORCYCLE HEADLIGHT**  
[75] **Inventor:** Tetsuo Ogishima, Saitama, Japan  
[73] **Assignee:** Honda Giken Kogyo Kabushiki Kaisha, Tokyo, Japan  
[\*\*] **Term:** 14 Years  
[21] **Appl. No.:** 321,397  
[22] **Filed:** Nov. 16, 1981

[30] **Foreign Application Priority Data**  
May 18, 1981 [JP] Japan ..... 56-21178  
[52] **U.S. Cl.** ..... D26/35  
[58] **Field of Search** ..... D26/28, 34, 35, 36,  
D26/120, 122, 123, 124; 362/61, 72, 83, 227,  
235, 296, 326, 327, 330-340

[56] **References Cited**  
**U.S. PATENT DOCUMENTS**  
D. 256,057 7/1980 Ichikawa ..... D26/29

**OTHER PUBLICATIONS**  
J. C. Whitney Auto Accessories Catalog, ©1979, p. 152, Motorcycle Fog & Driving Lights (driving light #88-9278x).  
*Primary Examiner*—Susan J. Lucas  
*Attorney, Agent, or Firm*—Irving M. Weiner; Pamela S. Burt; John L. Shortley

[57] **CLAIM**  
The ornamental design for a motorcycle headlight, as shown.

**DESCRIPTION**  
FIG. 1 is a perspective view of a motorcycle headlight showing my new design;  
FIG. 2 is a front elevational view thereof;  
FIG. 3 is a top plan view thereof;  
FIG. 4 is a side elevational view thereof; and  
FIG. 5 is a rear perspective view thereof.

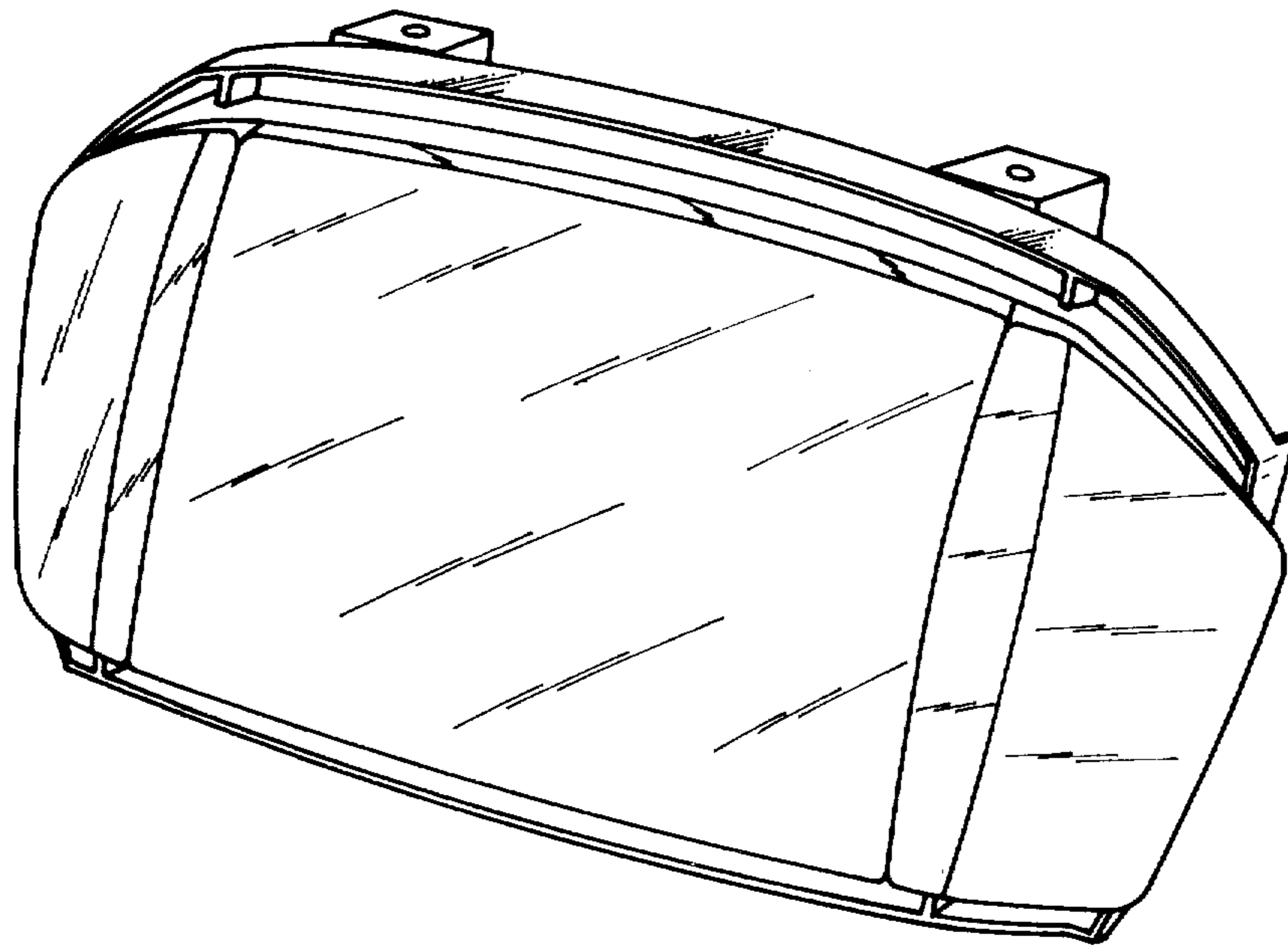

FIG.1

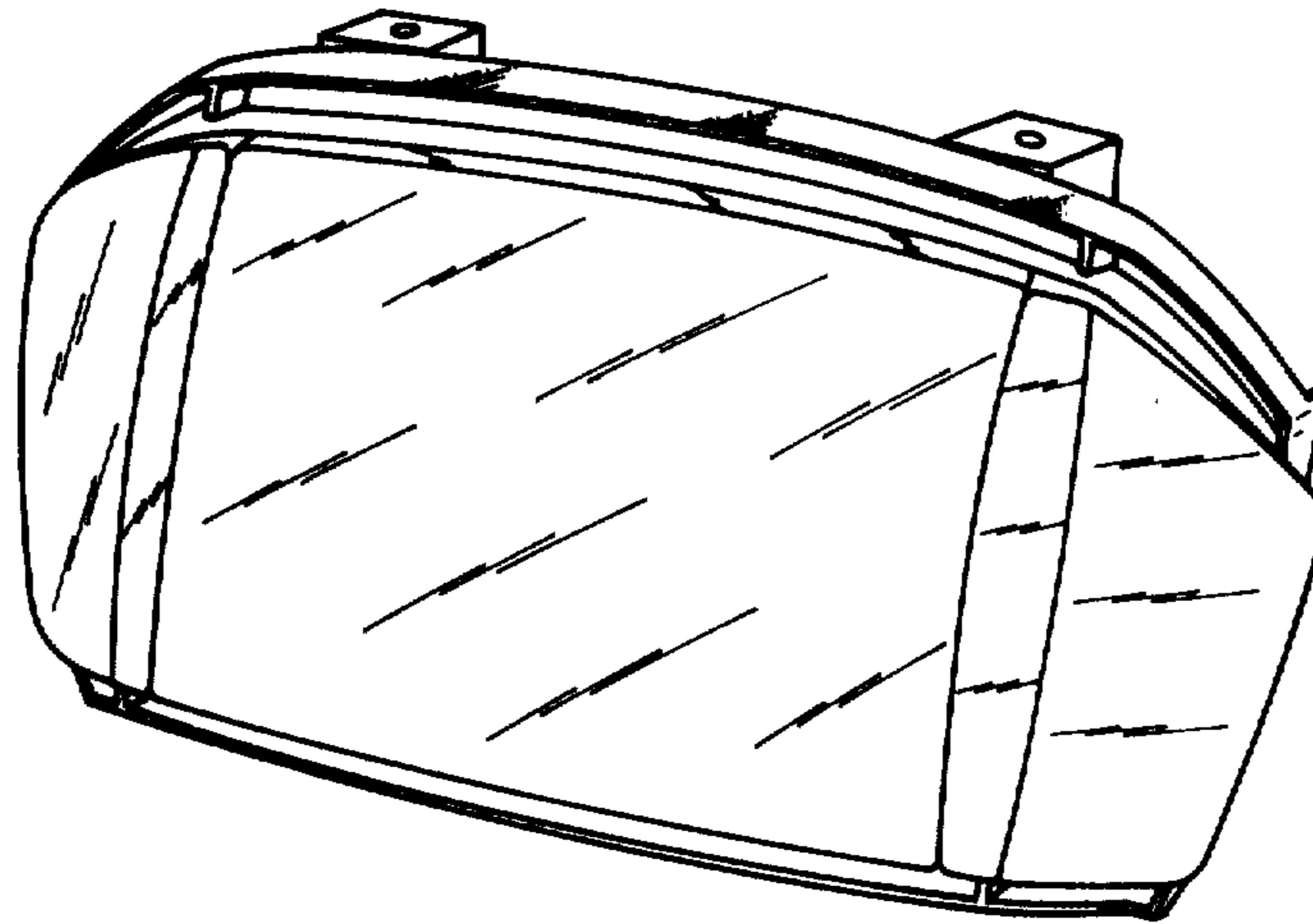

FIG.2

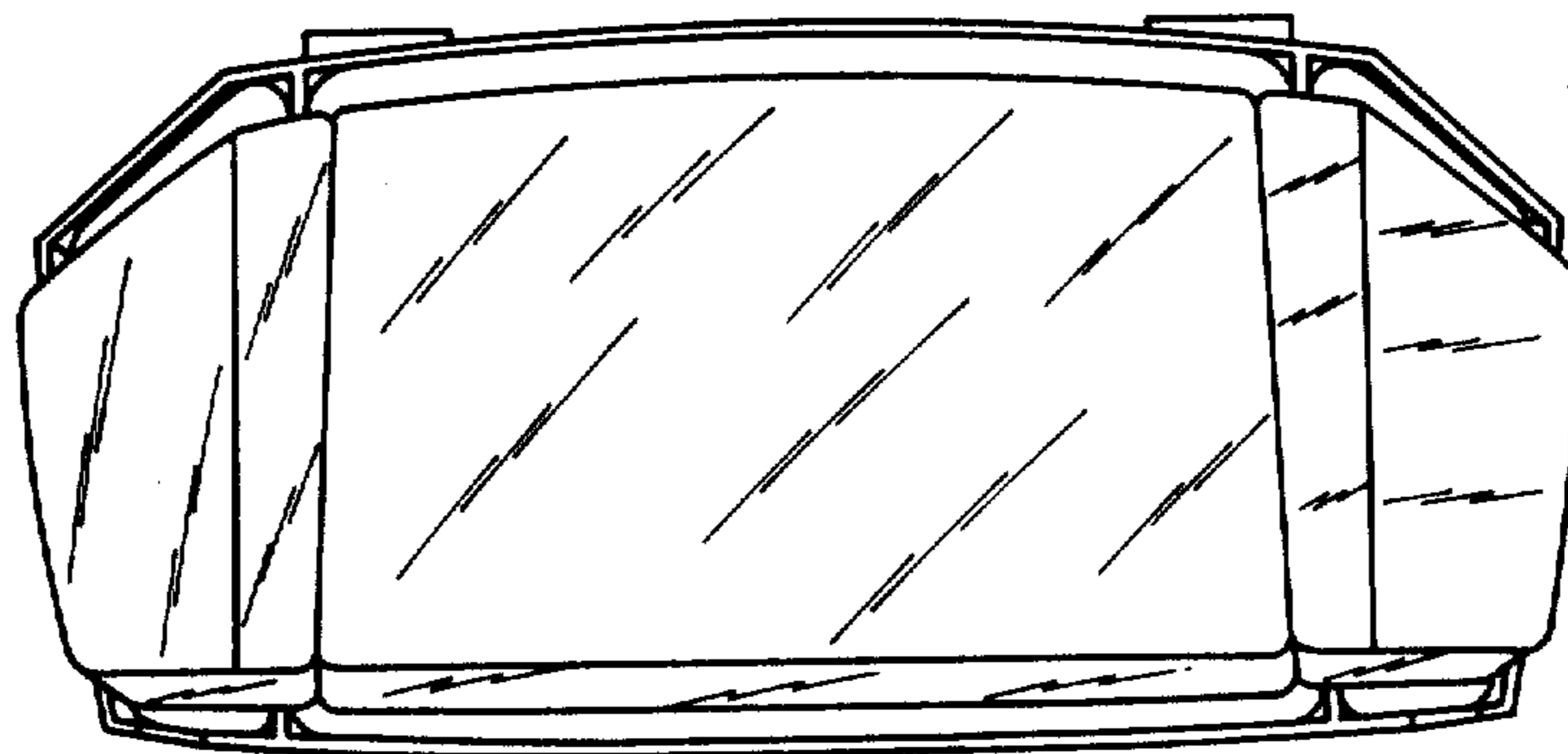

FIG.3

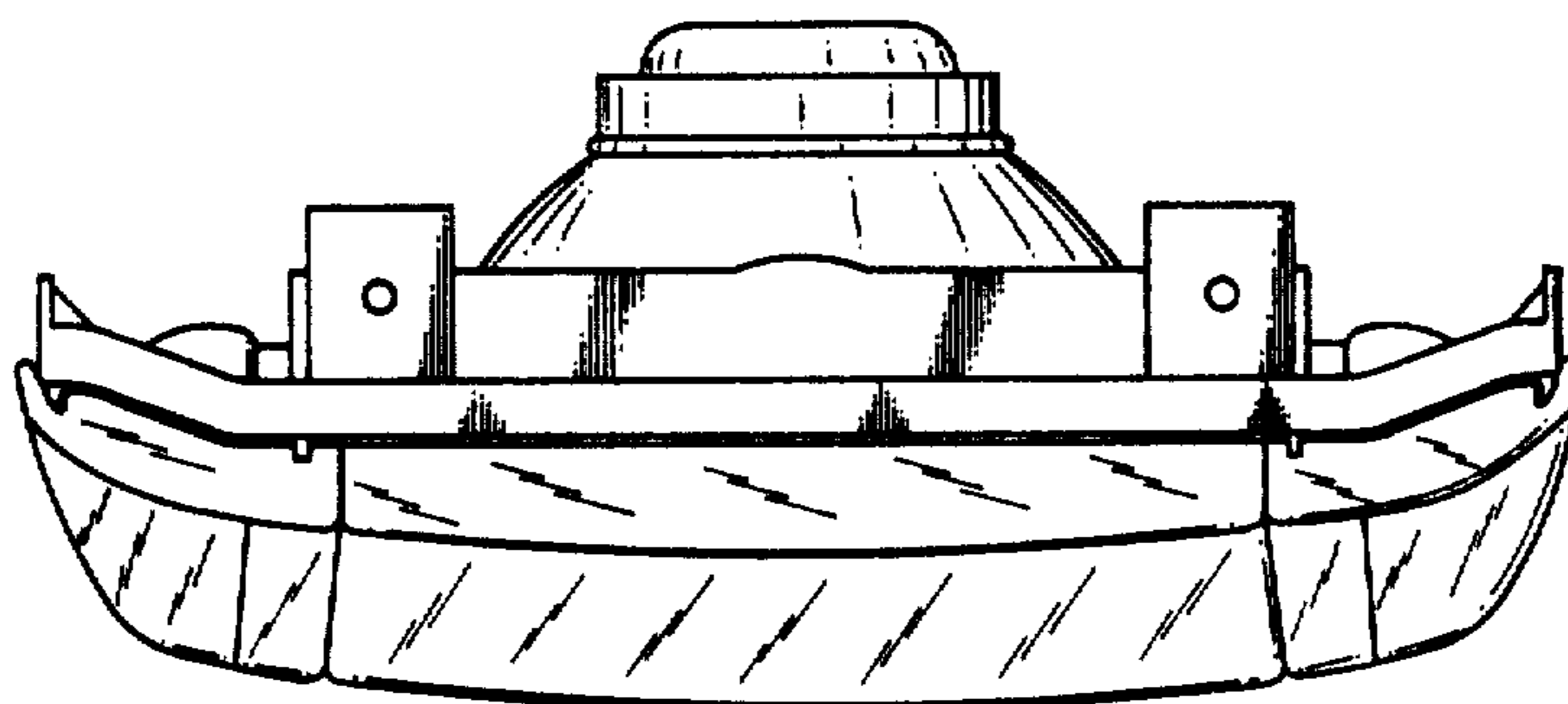

FIG.4

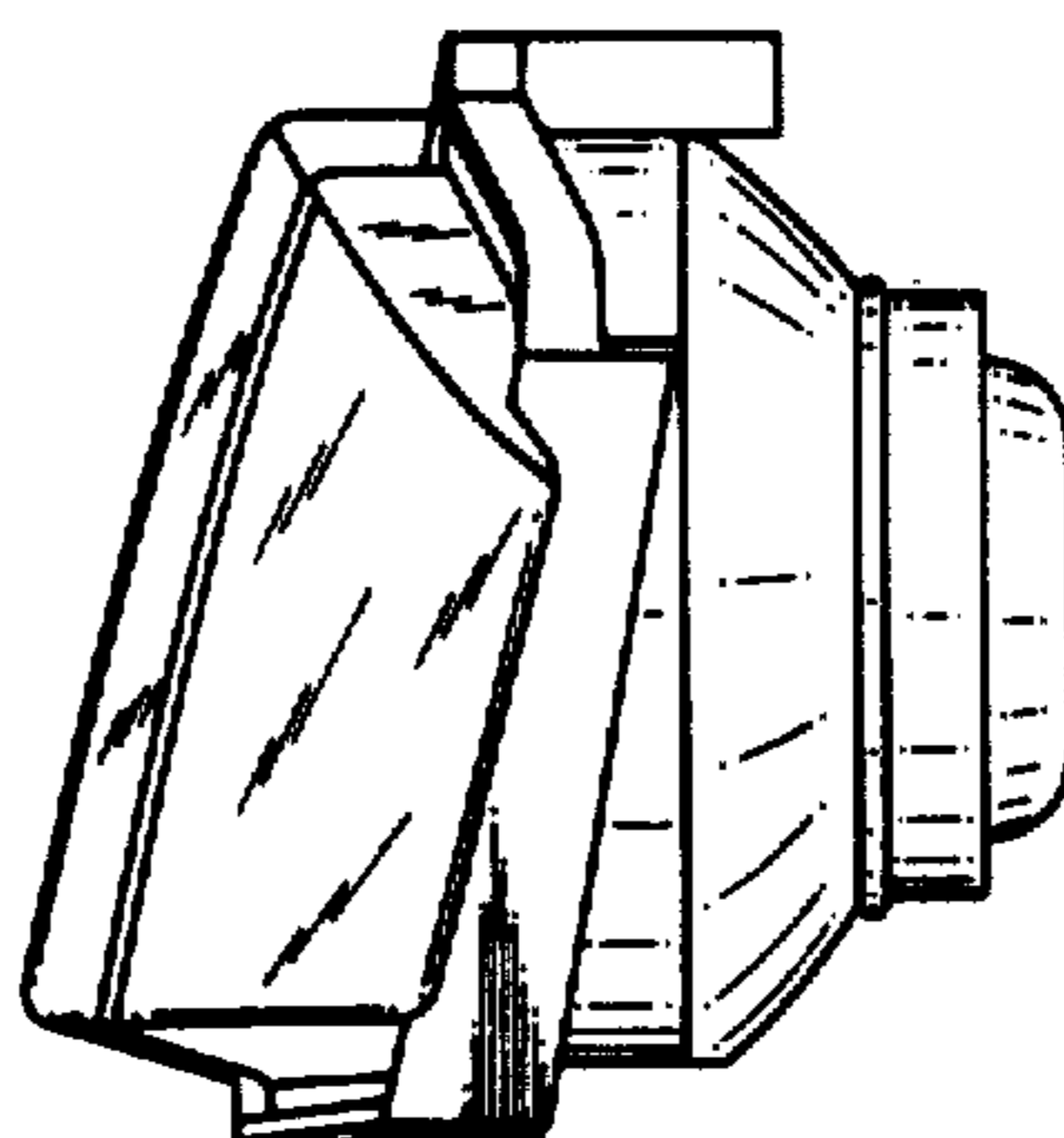

FIG. 5

