

[54] AIRCRAFT CONSOLE

[76] Inventor: David L. Benson, 7474 Carmel La., Grand Ledge, Mich. 48837

[\*\*] Term: 14 Years

[21] Appl. No.: 275,591

[22] Filed: Jun. 19, 1981

[52] U.S. Cl. .... D3/40; D12/345

[58] Field of Search ..... D3/40; D12/345; 108/44, 108/47, 48; 296/37.1, 37.8, 37.13, 37.14, 37.15, 37.16; 224/273, 42.11, 42.42

[56] References Cited

U.S. PATENT DOCUMENTS

D. 202,384	9/1965	Wilson	.....	D3/40 X
D. 207,916	6/1967	White	.....	D3/40
D. 232,871	9/1974	George et al.	.....	D3/40
D. 248,056	5/1978	Nepper	.....	D3/40

Primary Examiner—Catherine E. Kemper  
Attorney, Agent, or Firm—Miller, Morriss & Pappas

[57] CLAIM

The ornamental design for an aircraft console, as shown and described.

DESCRIPTION

FIG. 1 is a right perspective view of an aircraft console showing my new design.

FIG. 2 is a right perspective view of a second embodiment of an aircraft console, which differs from the first embodiment only in the arrangement of the interior compartments;

FIG. 3 is a front elevational view of the aircraft console; FIG. 4 is a side elevational view thereof, the opposite side being a mirror image thereof.

FIG. 5 is a rear elevational view thereof.

FIG. 6 is a top plan view thereof, shown on a smaller scale;

FIG. 7 is a bottom perspective view thereof.

The broken line disclosure of an airplane cabin in FIG. 6 is for illustrative purposes only and forms no part of the claimed design.

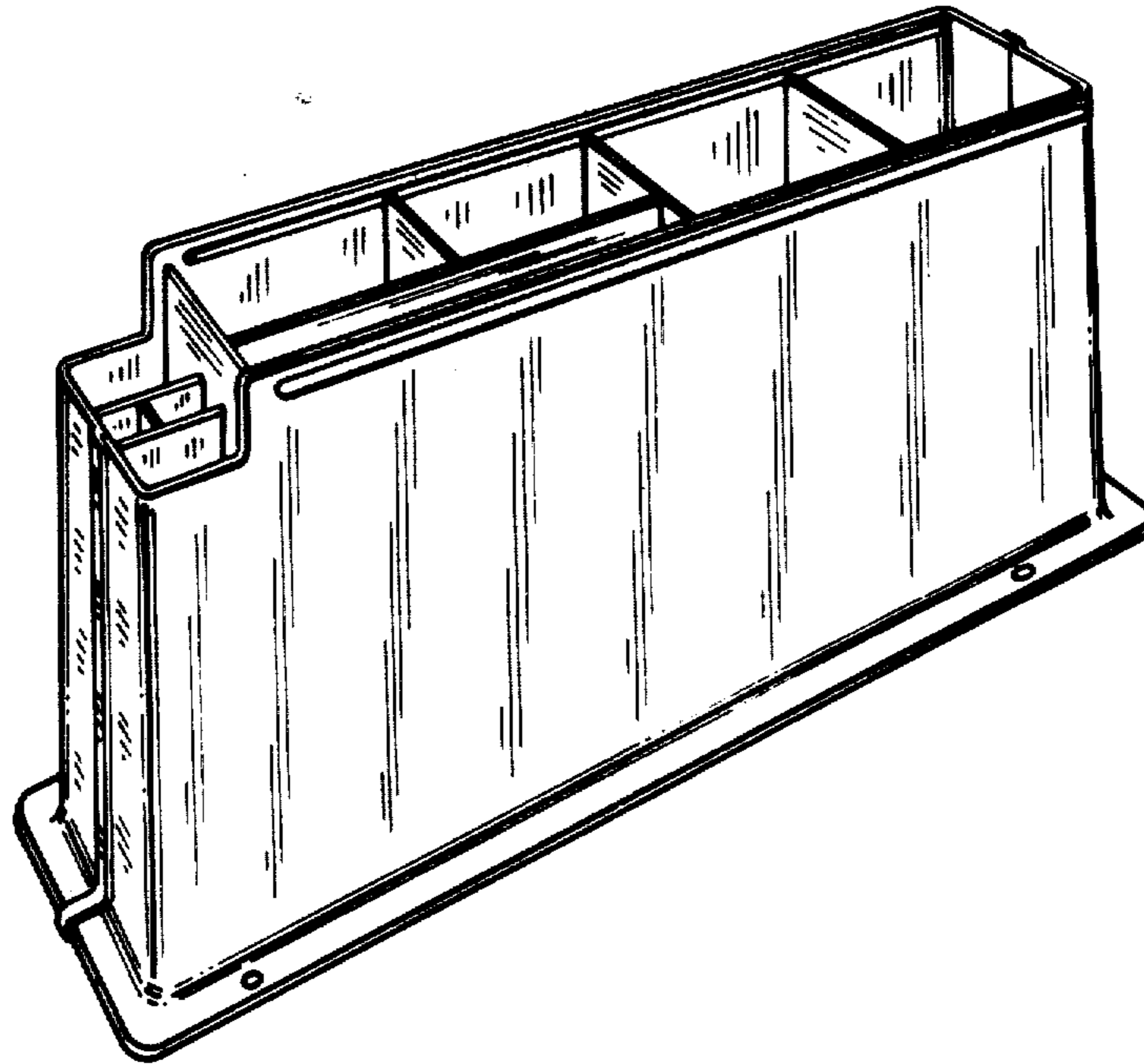

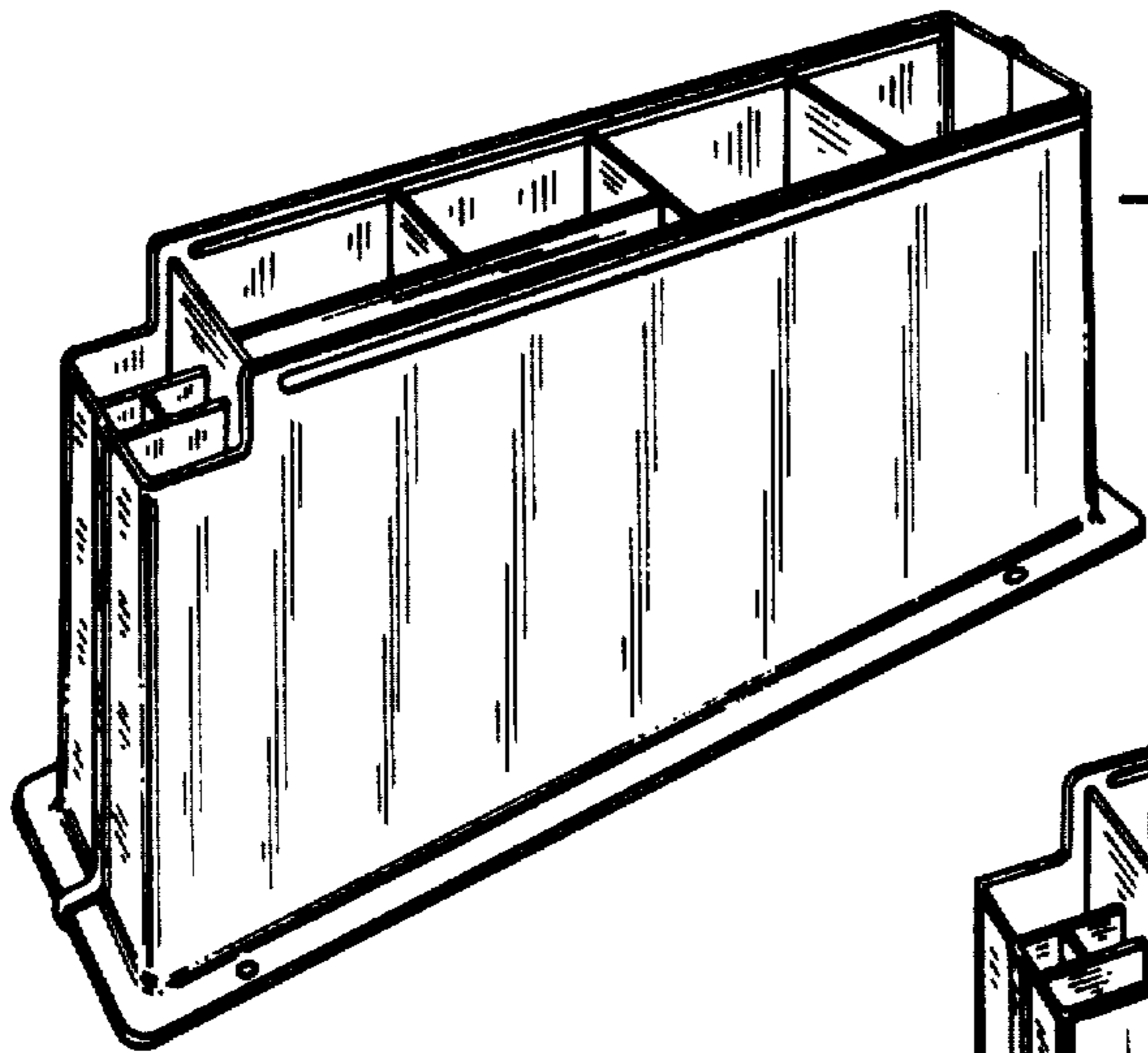

FIG. 1

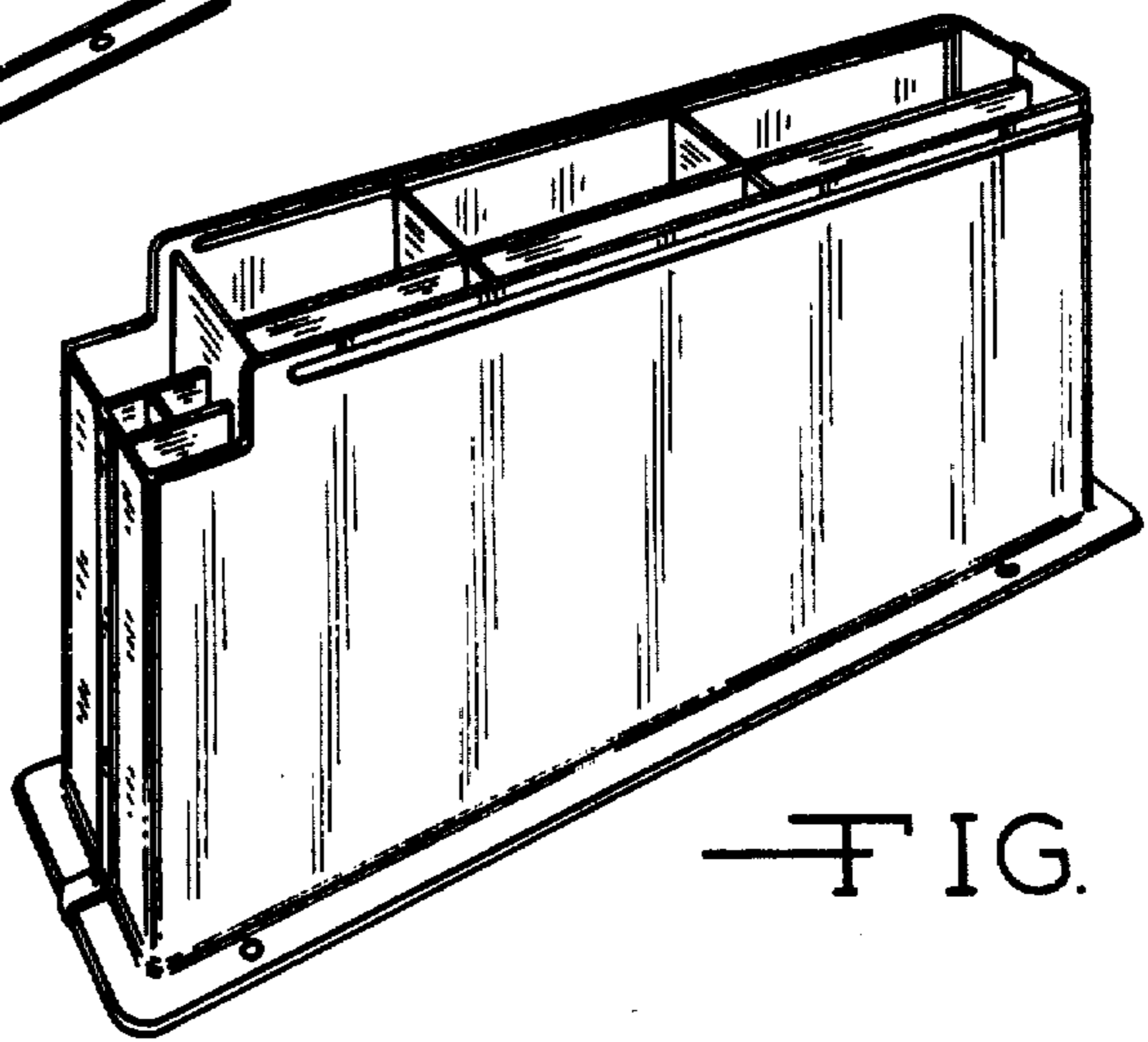

FIG. 2

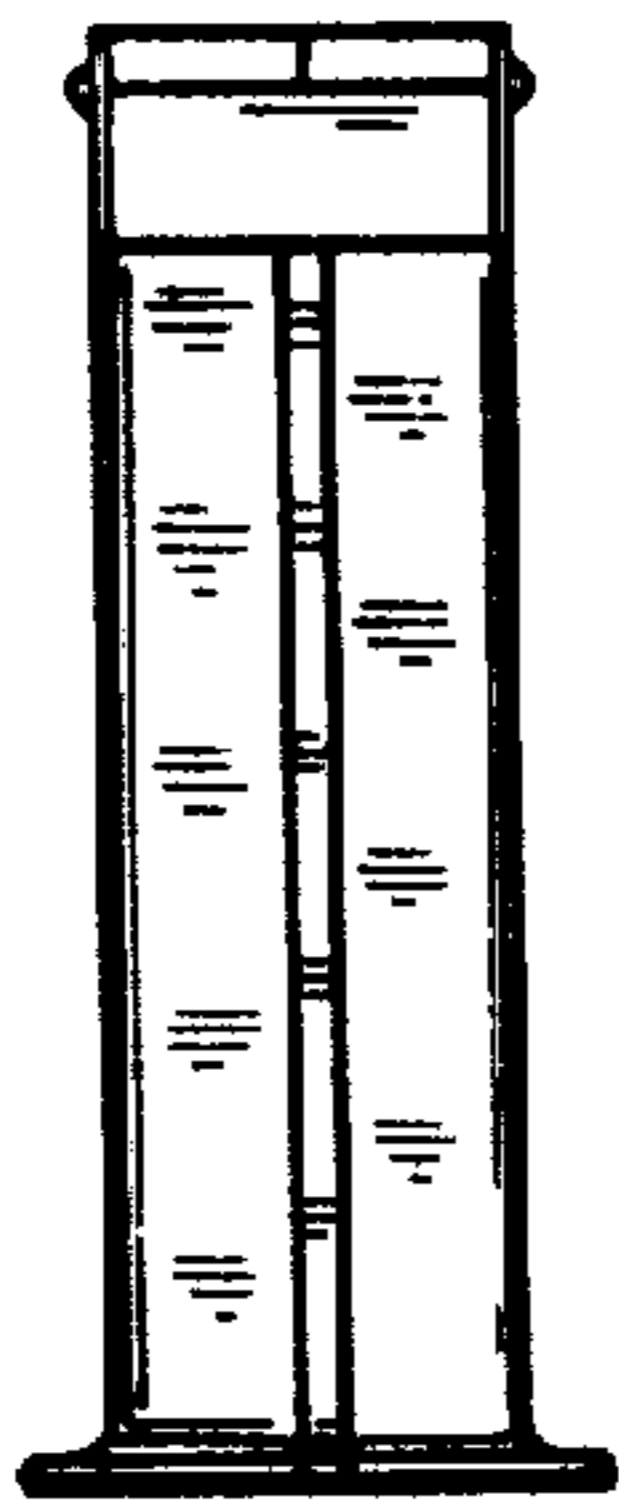

FIG. 3

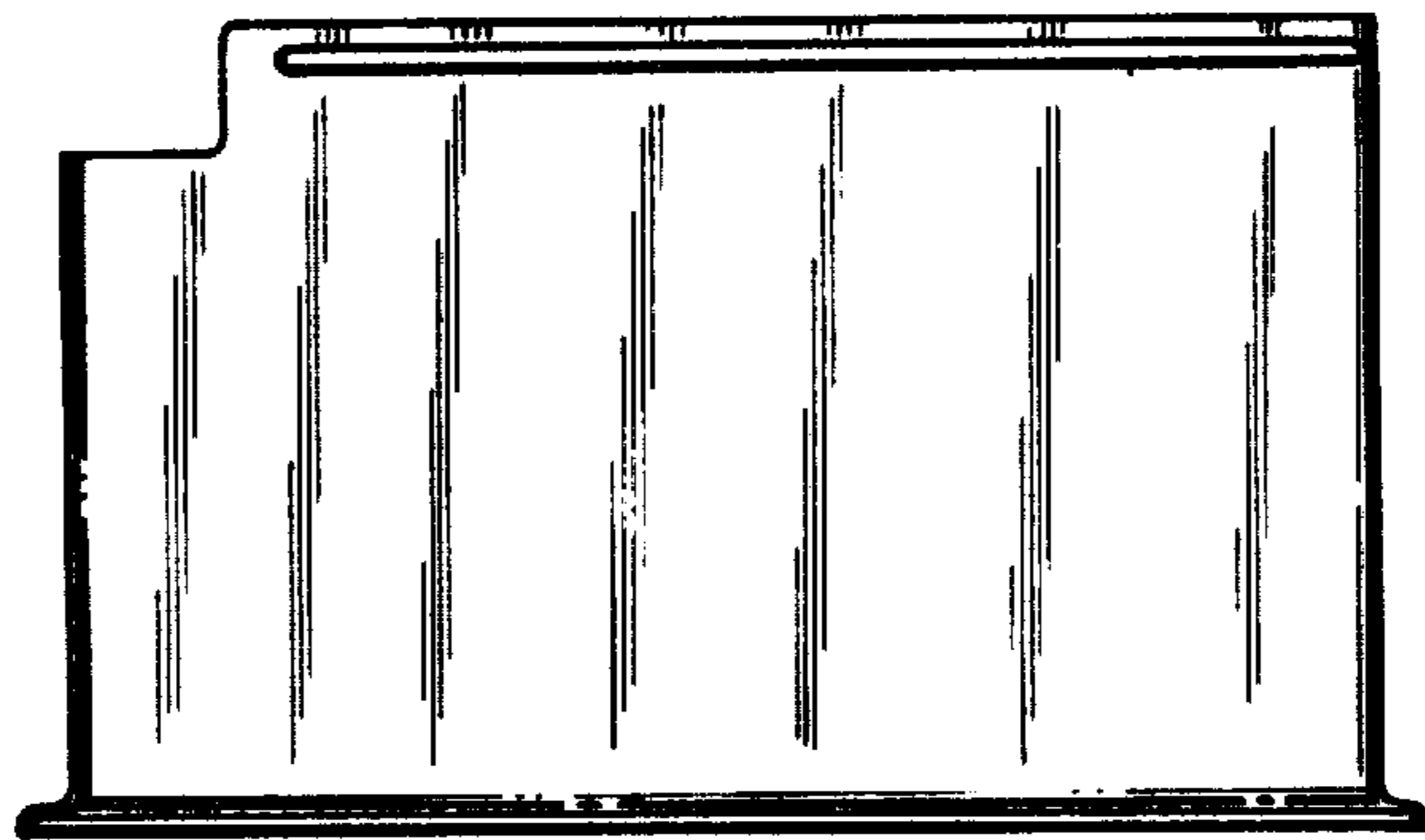
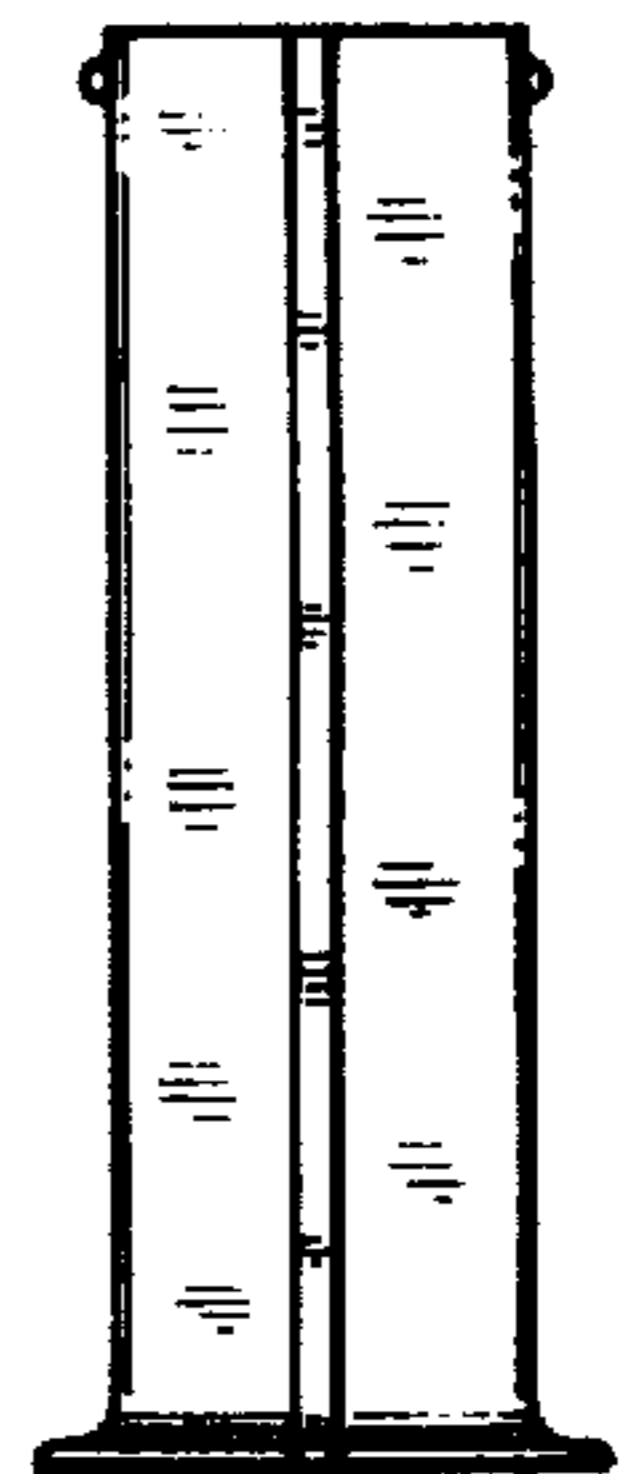
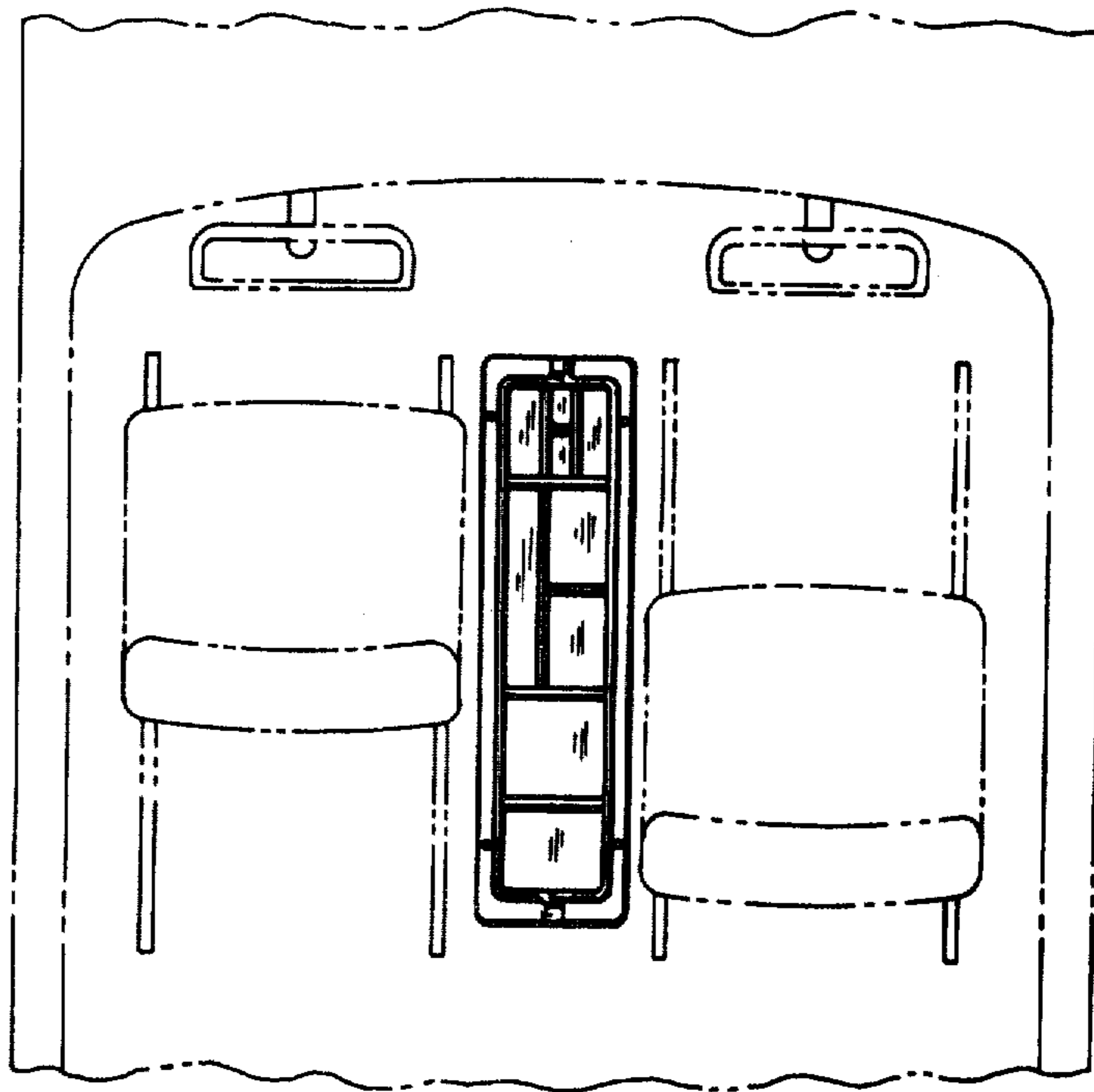

FIG. 4

FIG. 5





— FIG. 6

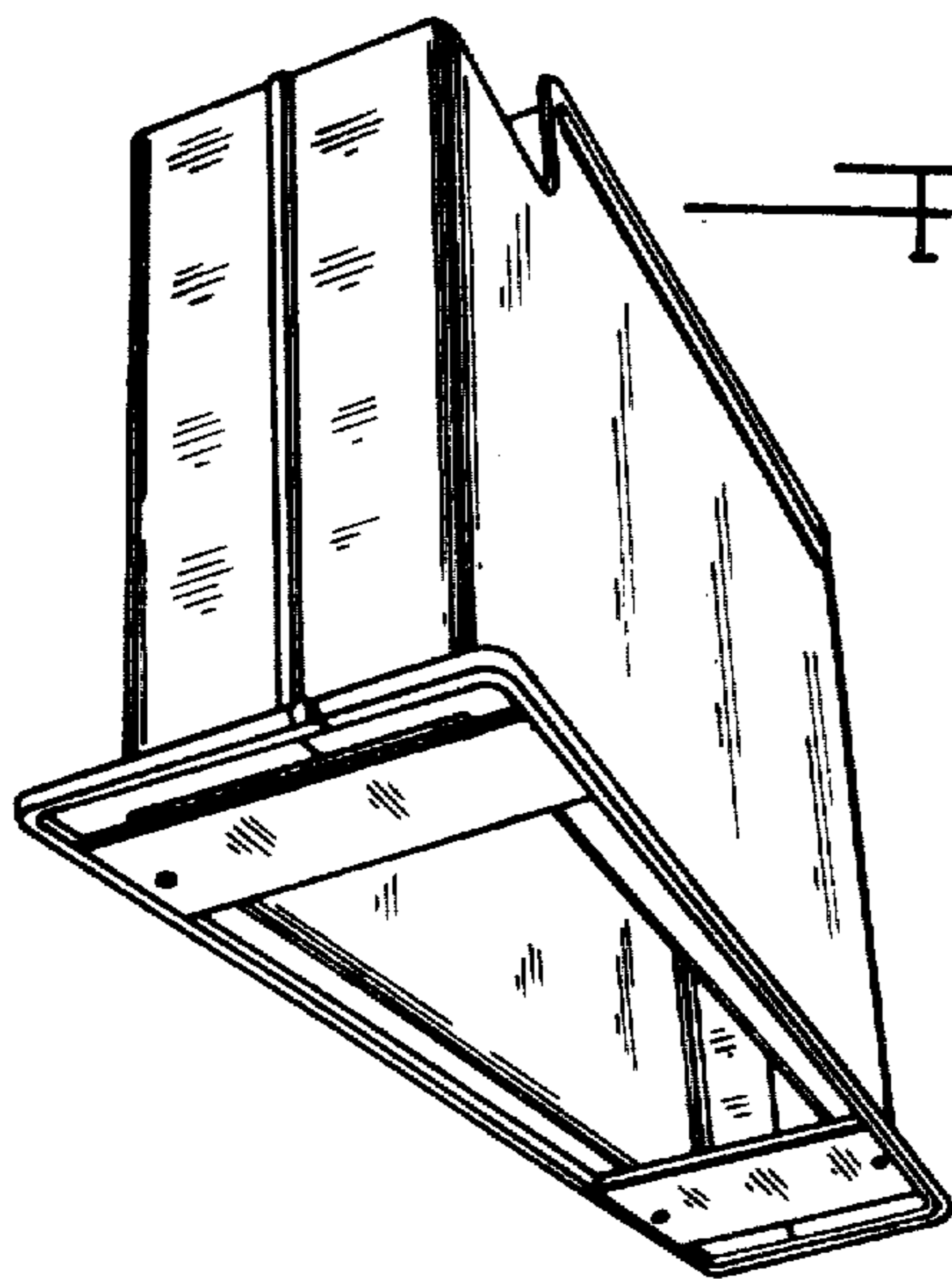

— FIG. 7