

[54] **WHEEL**

[75] **Inventor:** **Richard R. Woodward**, Yalding,  
England

[73] **Assignee:** **GKN Kent Alloys Limited**, England

[\*\*] **Term:** **14 Years**

[21] **Appl. No.:** **300,162**

[22] **Filed:** **Sep. 8, 1981**

[30] **Foreign Application Priority Data**

Apr. 7, 1981 [GB] United Kingdom ..... 81 999832  
[52] **U.S. Cl.** ..... **D12/209**  
[58] **Field of Search** ..... D12/209, 210, 211;  
301/63 R, 63 PW, 64 R, 64 SD, 65

[56] **References Cited**

**U.S. PATENT DOCUMENTS**

D. 232,930 9/1974 Edwards ..... D12/210  
D. 235,328 6/1975 Scriver ..... D12/211  
4,165,131 8/1979 Thompson ..... 301/65

**FOREIGN PATENT DOCUMENTS**

1057342 6/1979 Canada ..... 301/63 R

*Primary Examiner*—James M. Gandy  
*Attorney, Agent, or Firm*—Merriam, Marshall & Bicknell

[57] **CLAIM**

The ornamental design for a wheel, as shown.

**DESCRIPTION**

FIG. 1 is a view in front elevation of a wheel showing my new design;  
FIG. 2 is a rear elevation view thereof;  
FIG. 3 is a section view thereof taken along line 3—3 in FIG. 1; and  
FIG. 4 is a side elevation view thereof.

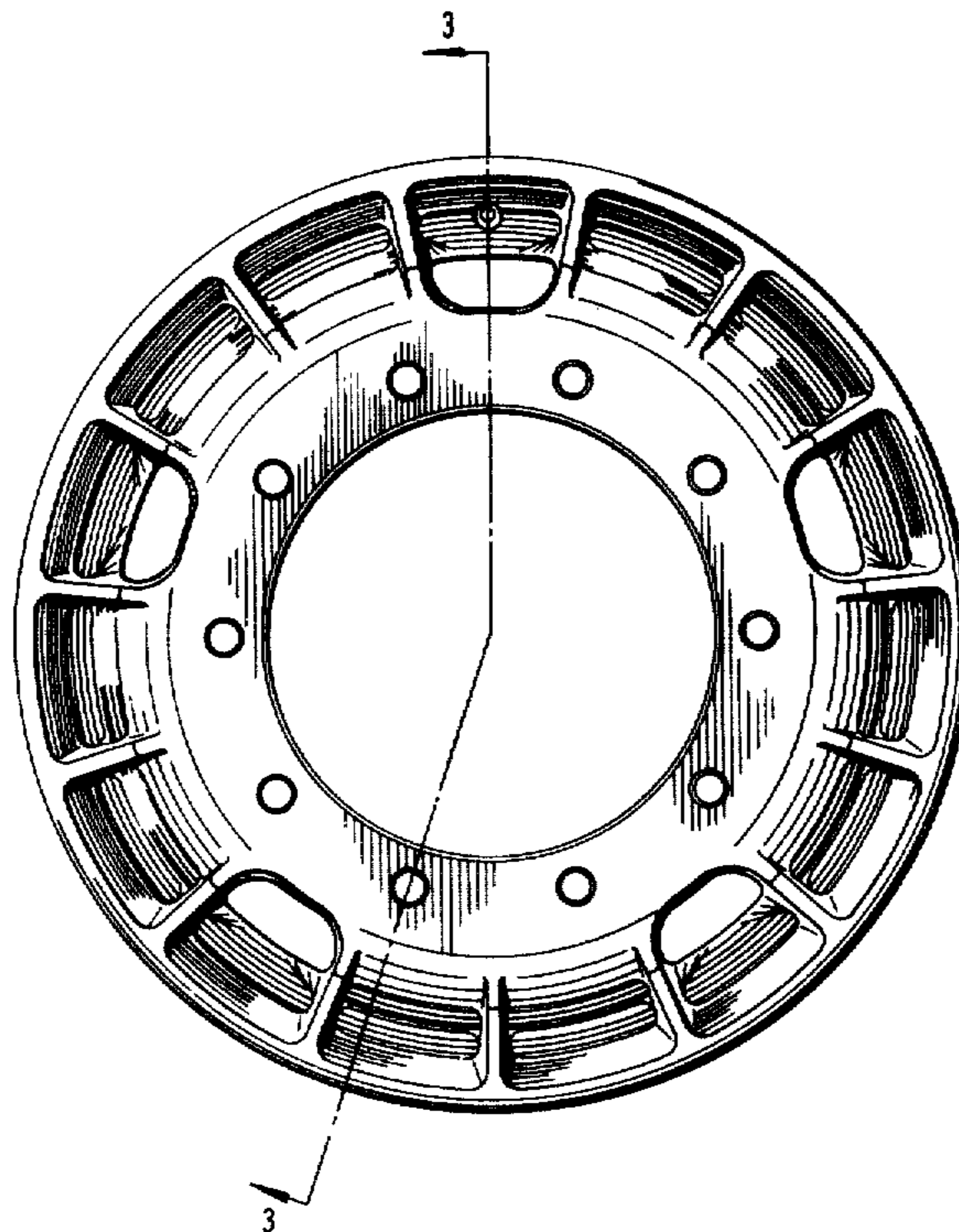

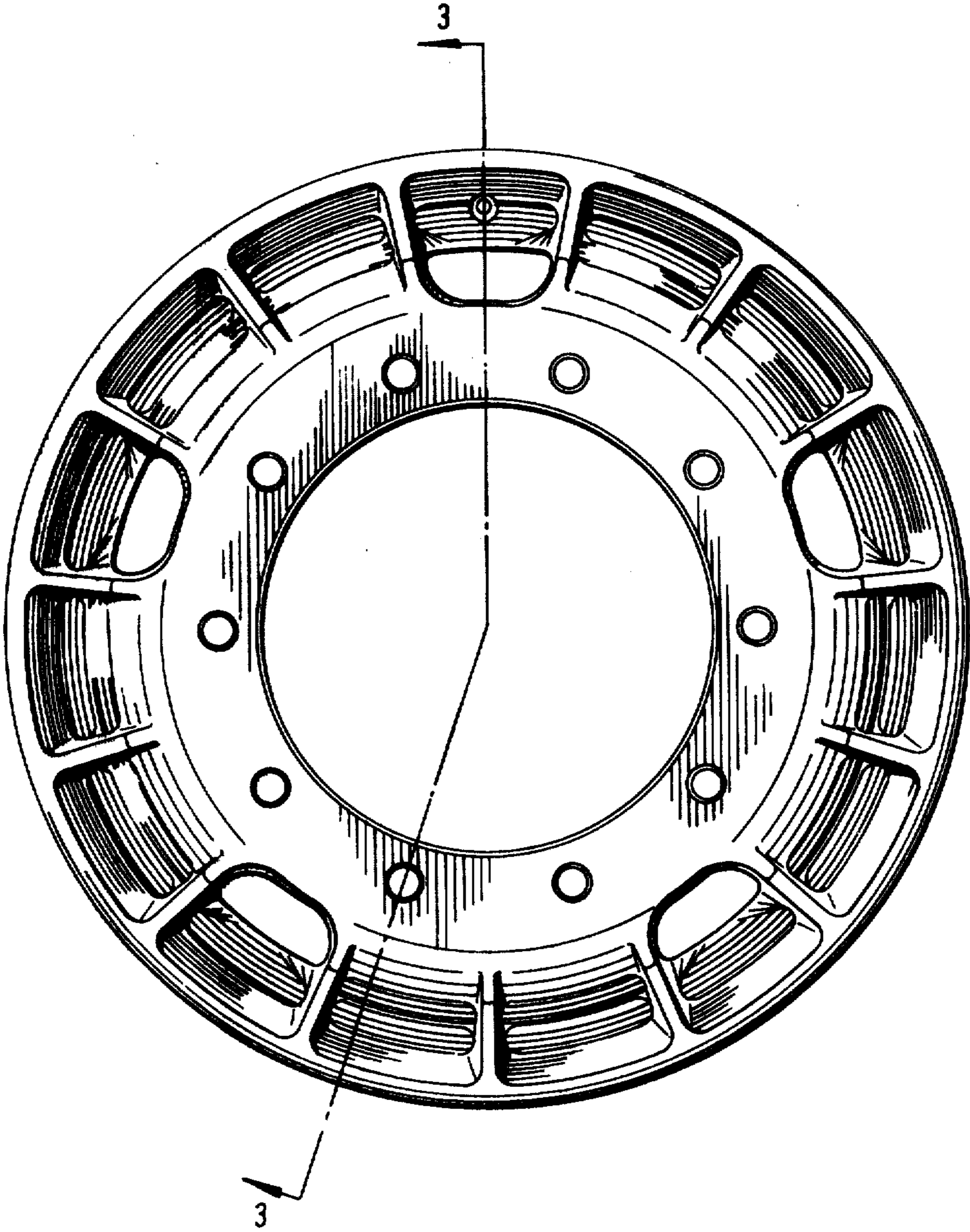

FIG. 1.

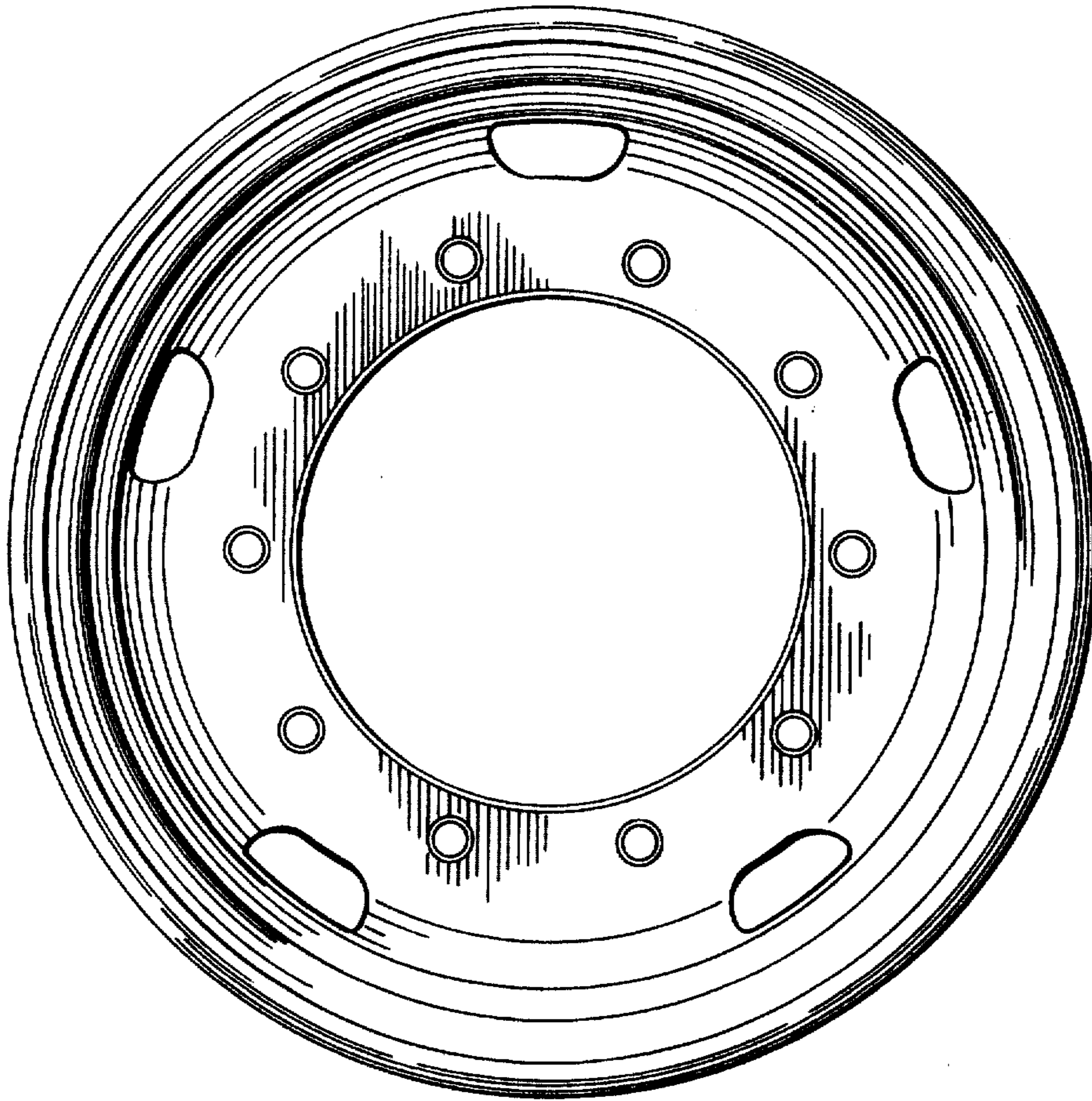

FIG. 2.



FIG. 3.

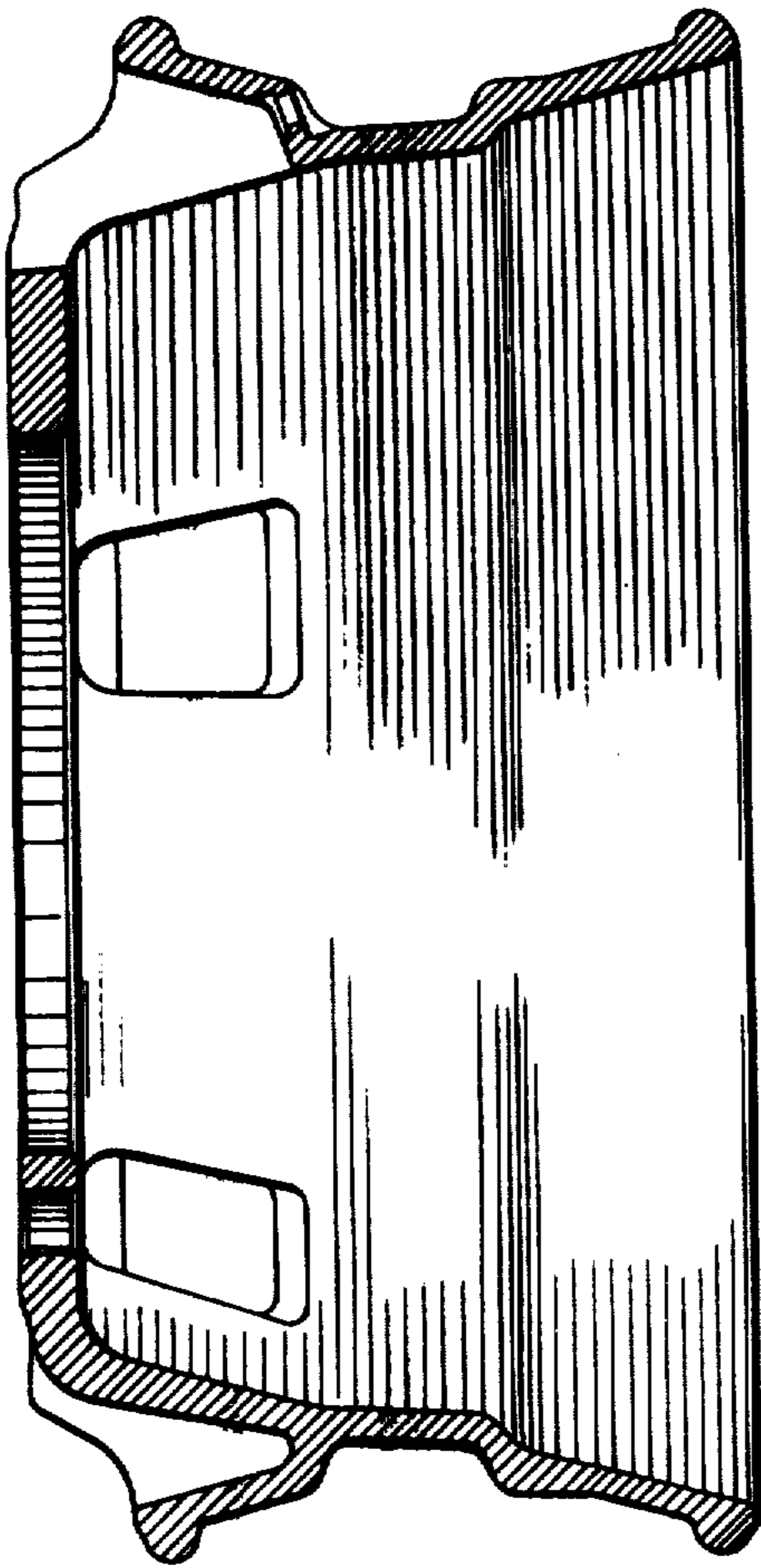

FIG. 4.

