

[54] **AUTOMOBILE**

[75] **Inventor:** Teruhiko Ohhashi, Hamamatsu,
Japan

[73] **Assignee:** Suzuki Motor Co. Ltd., Kamimura,
Japan

[**] **Term:** 14 Years

[21] **Appl. No.:** 249,829

[22] **Filed:** Apr. 1, 1981

[52] **U.S. Cl.** D12/90

[58] **Field of Search** D12/90; 296/185

[56]

References Cited

U.S. PATENT DOCUMENTS

D. 179,549 1/1957 Rivolta D12/90
D. 184,733 3/1959 Hofmeister D12/90

Primary Examiner—James M. Gandy
Attorney, Agent, or Firm—Holman & Stern

[57]

CLAIM

The ornamental design for an automobile, substantially as shown and described.

DESCRIPTION

FIG. 1 is a front elevation view of the automobile showing my new design;

FIG. 2 is a rear elevation view thereof;

FIG. 3 is a top plan view thereof;

FIG. 4 is a left side elevation view thereof; and

FIG. 5 is a right side elevation view thereof.

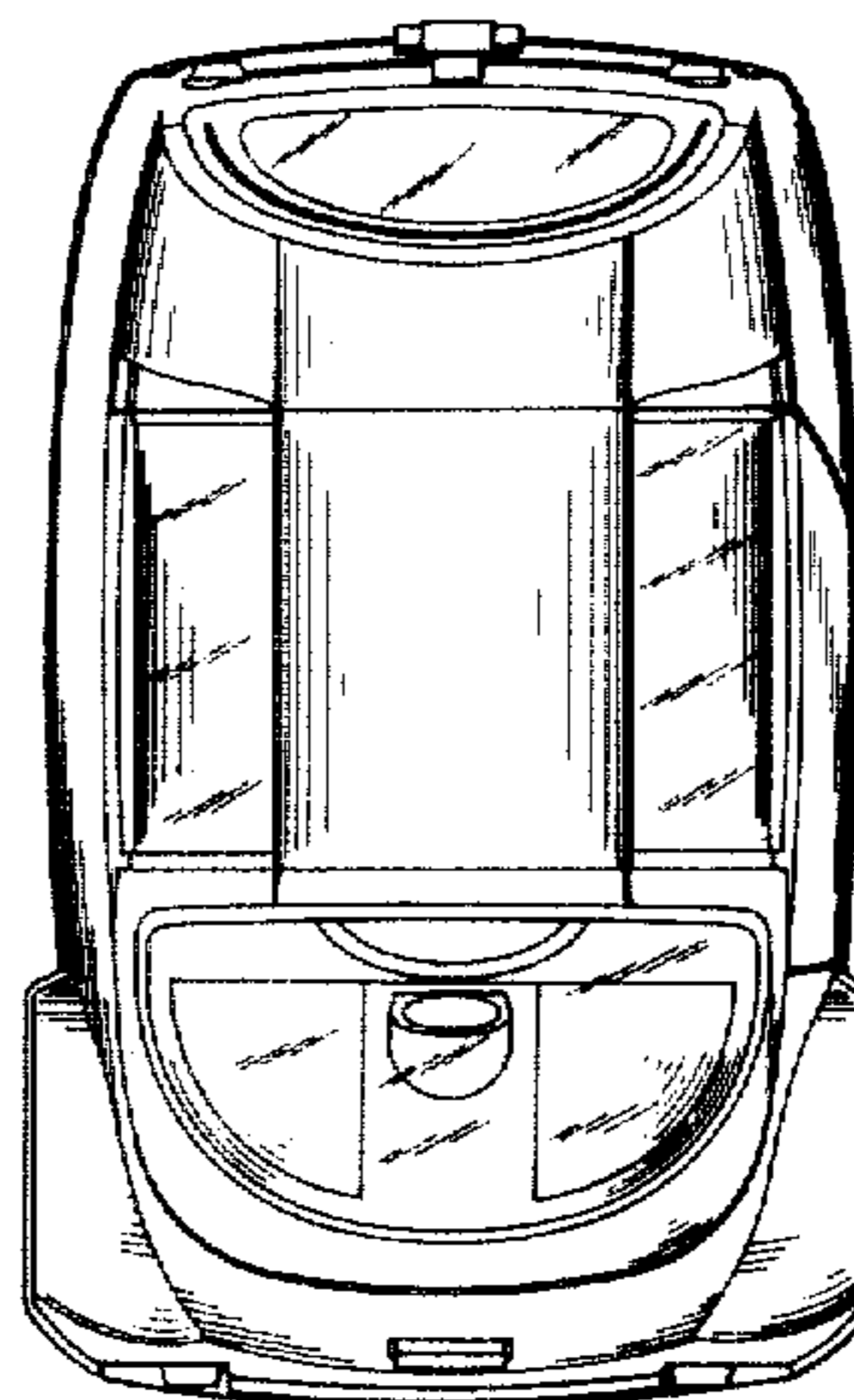
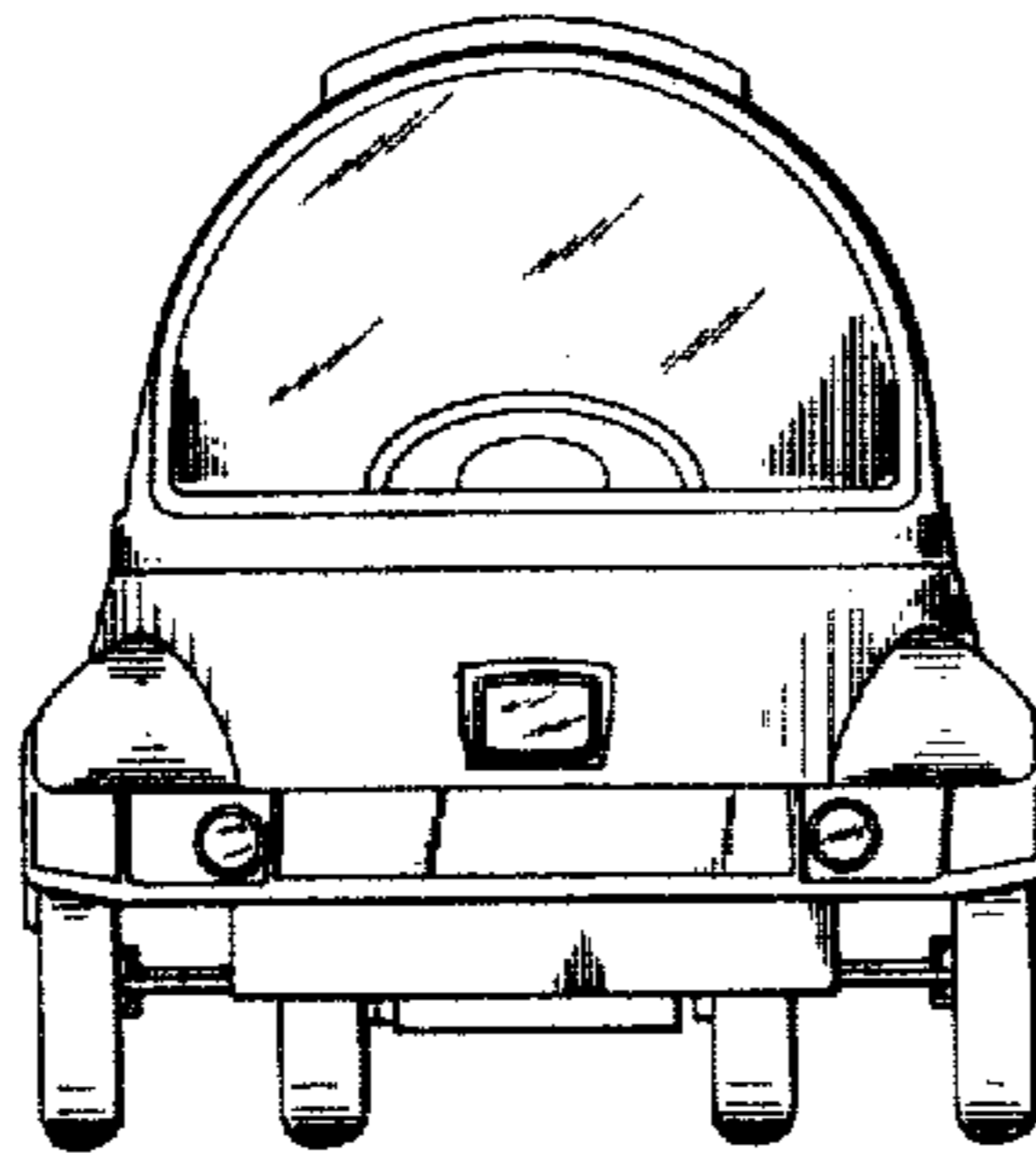

FIG. 1

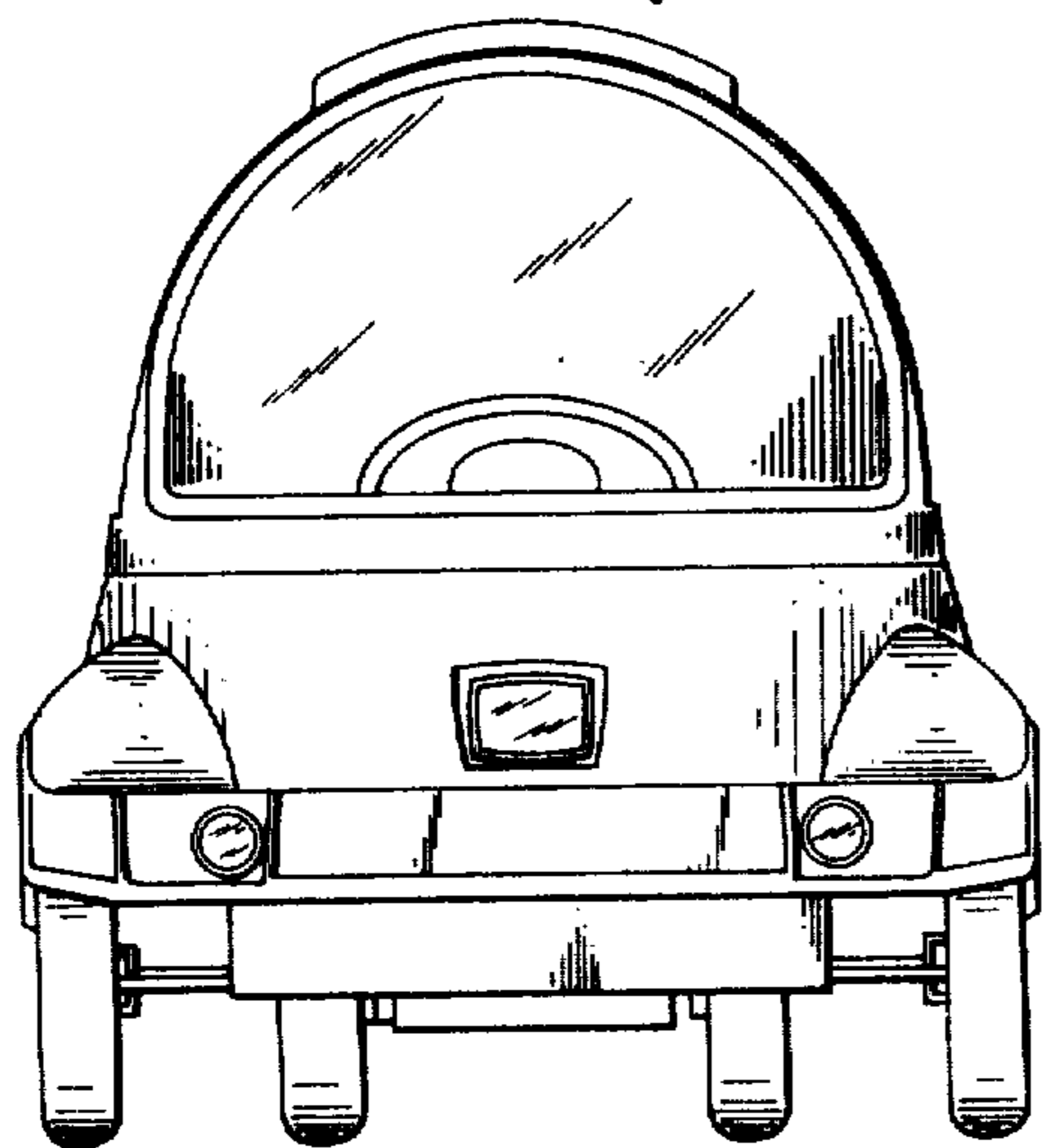

FIG. 2

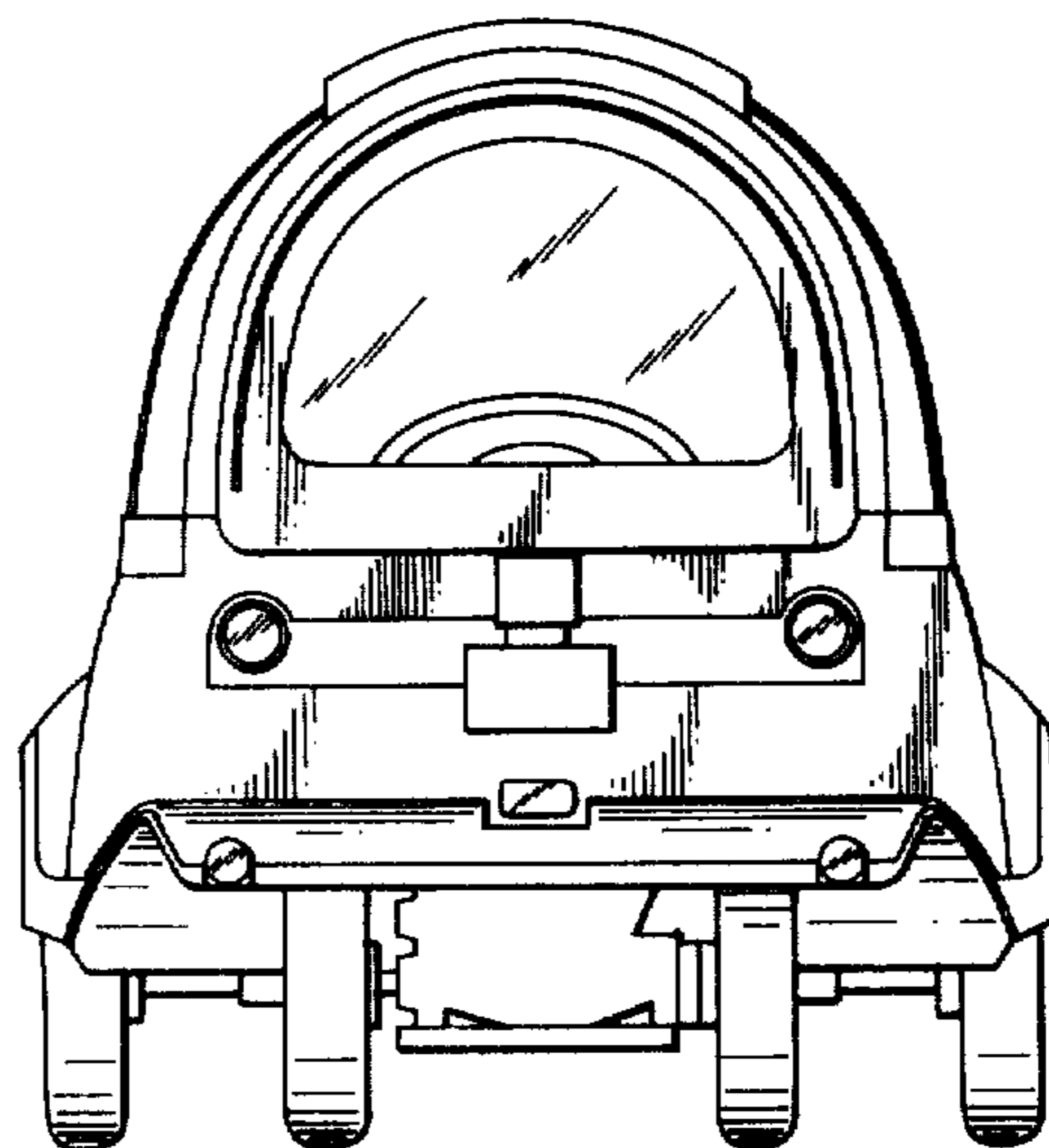

FIG. 3

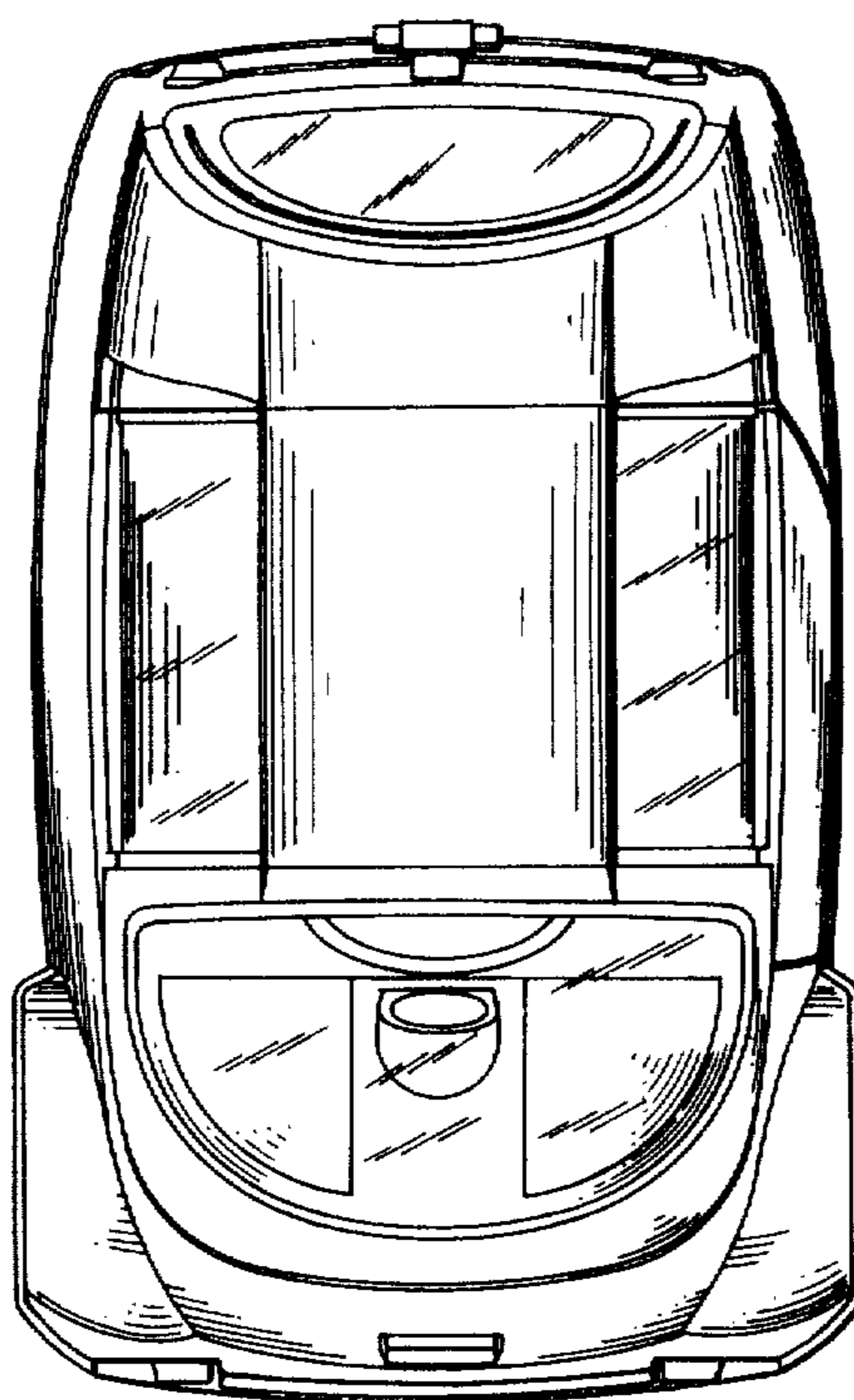

FIG. 4

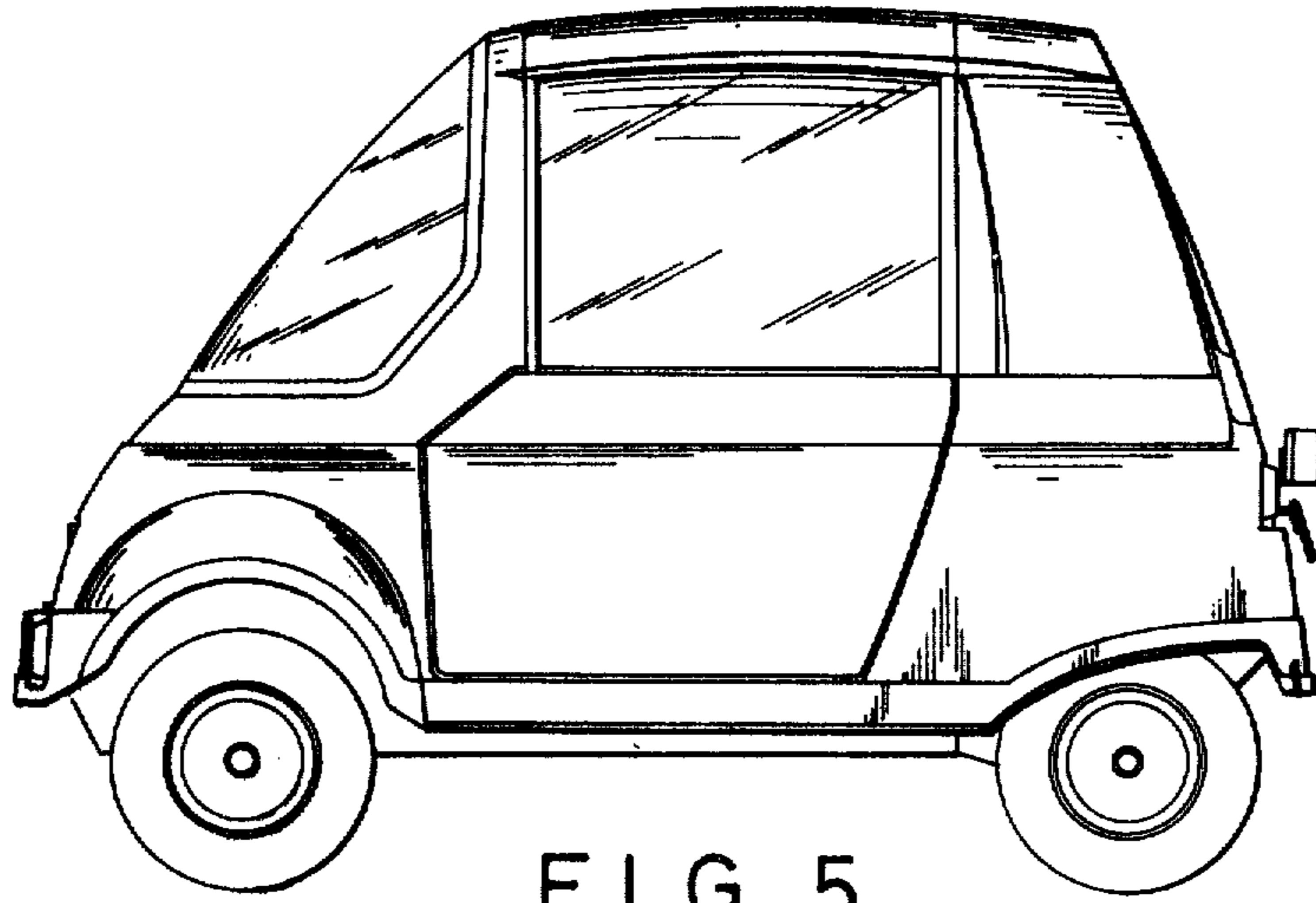

FIG. 5

