

[54] PROPELLER COUNTERWEIGHT BEARING ASSEMBLY

[75] Inventor: Kerry G. Dawes, Palo Cedro, Calif.

[73] Assignee: Dennis A. Praegitzer, Palo Cedro, Calif.

[\*\*] Term: 14 Years

[21] Appl. No.: 316,452

[22] Filed: Oct. 30, 1981

[51] Int. Cl. .... D15-99

[52] U.S. Cl. .... D15/143

[58] Field of Search ..... D15/5, 143; D12/214; D23/47; D8/354, 355, 399; 308/184 R, 184 A, DIG. 12; 384/428, 438

[56] References Cited

U.S. PATENT DOCUMENTS

D. 268,566	4/1983	Friberg .....	D8/399
2,531,334	11/1950	Grenat .....	384/438
3,966,275	6/1976	Cain et al. ....	384/428
4,208,076	6/1980	Gray et al. ....	384/428
4,251,121	2/1981	Johne et al. ....	384/428

Primary Examiner—Wallace R. Burke  
Assistant Examiner—Lynn Wilder  
Attorney, Agent, or Firm—Lothrop & West

[57] CLAIM

The ornamental design for a propeller counterweight bearing assembly, as shown and described.

DESCRIPTION

FIG. 1 is a right front perspective view of a propeller counterweight bearing assembly, showing my new design;  
FIG. 2 is a front elevational view;  
FIG. 3 is a side elevational view taken from the left hand side of the article as shown in FIG. 2, the right side elevational view being substantially a mirror image thereof;  
FIG. 4 is a rear elevational view;  
FIG. 5 is a top plan view;  
FIG. 6 is a top plan view, showing the counterweight bearing outer race in an arbitrary, alternative position, the outer race being adapted to slide freely within the kidney shaped inner race;  
FIG. 7 is a bottom plan view; and,  
FIG. 8 is a median, transverse, cross-sectional view, taken on the line 8-8 in FIG. 5.

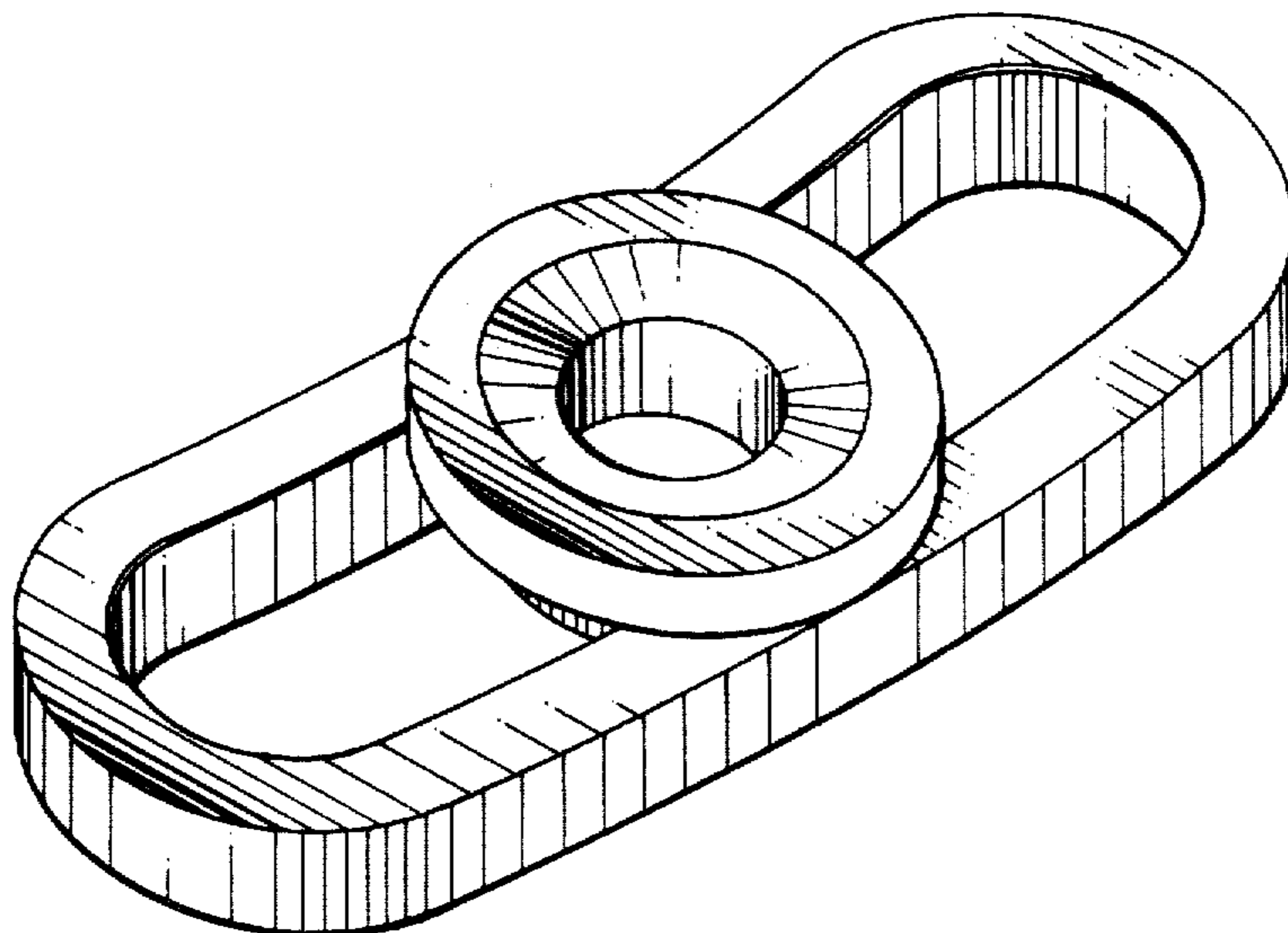

FIG - 1

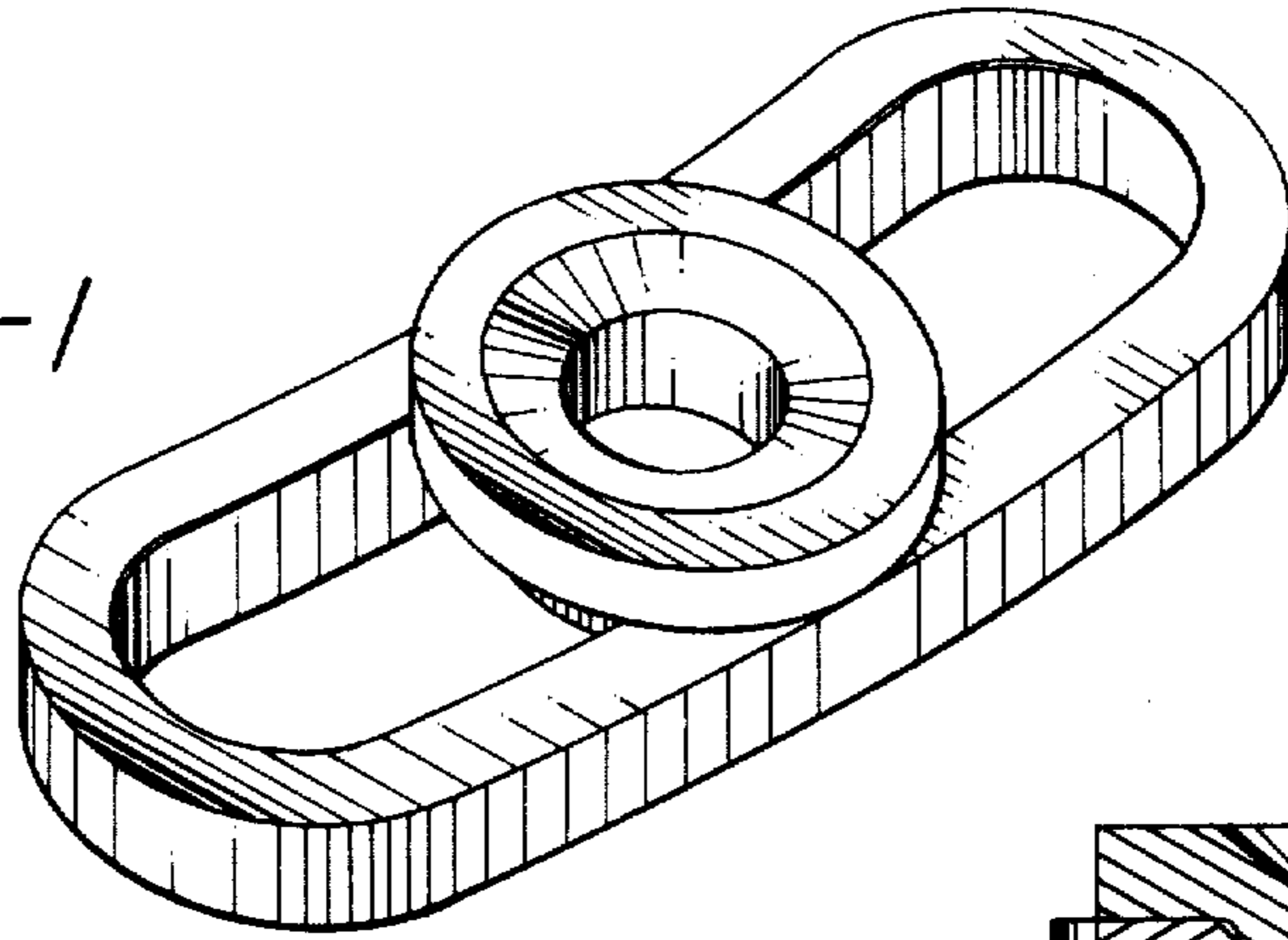

FIG - 2

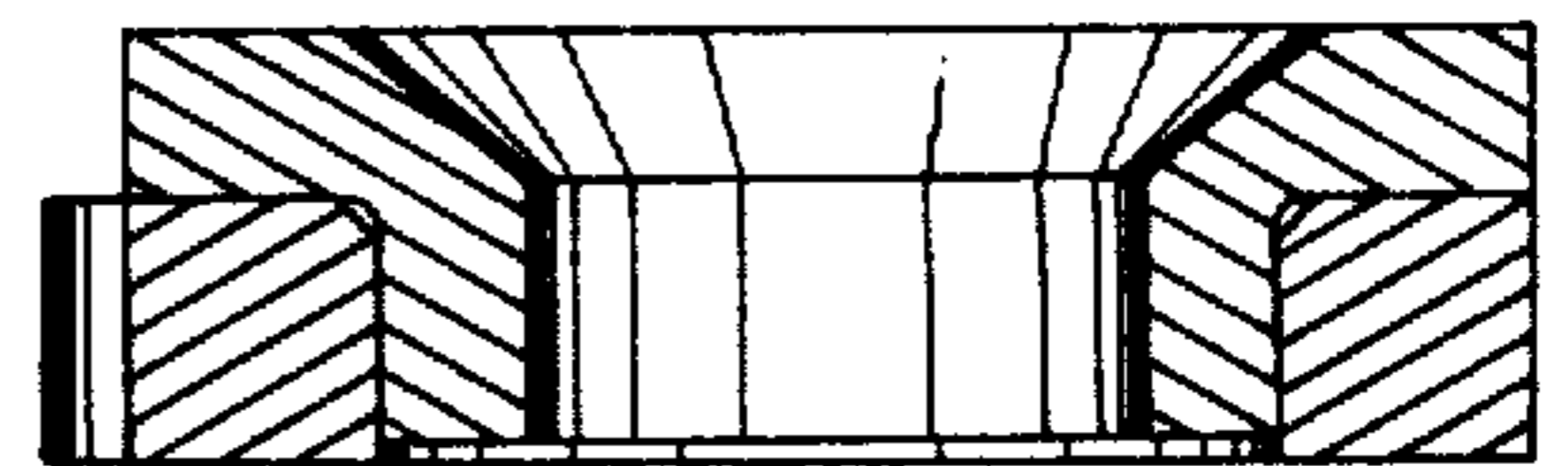
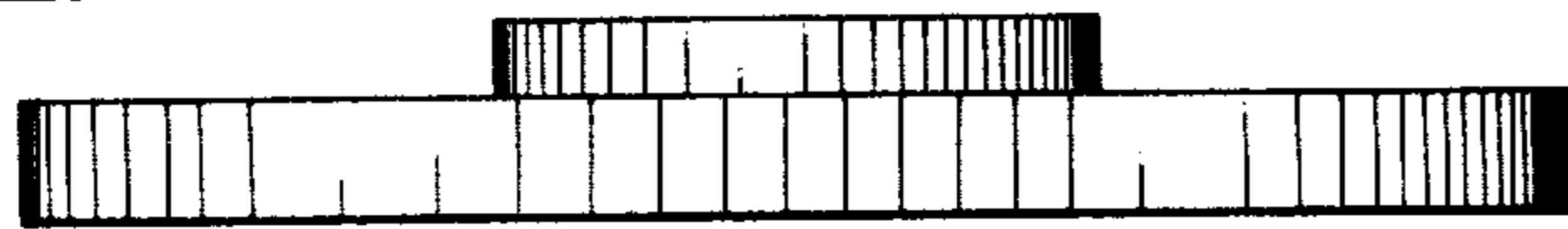

FIG - 8



FIG - 3

FIG - 4

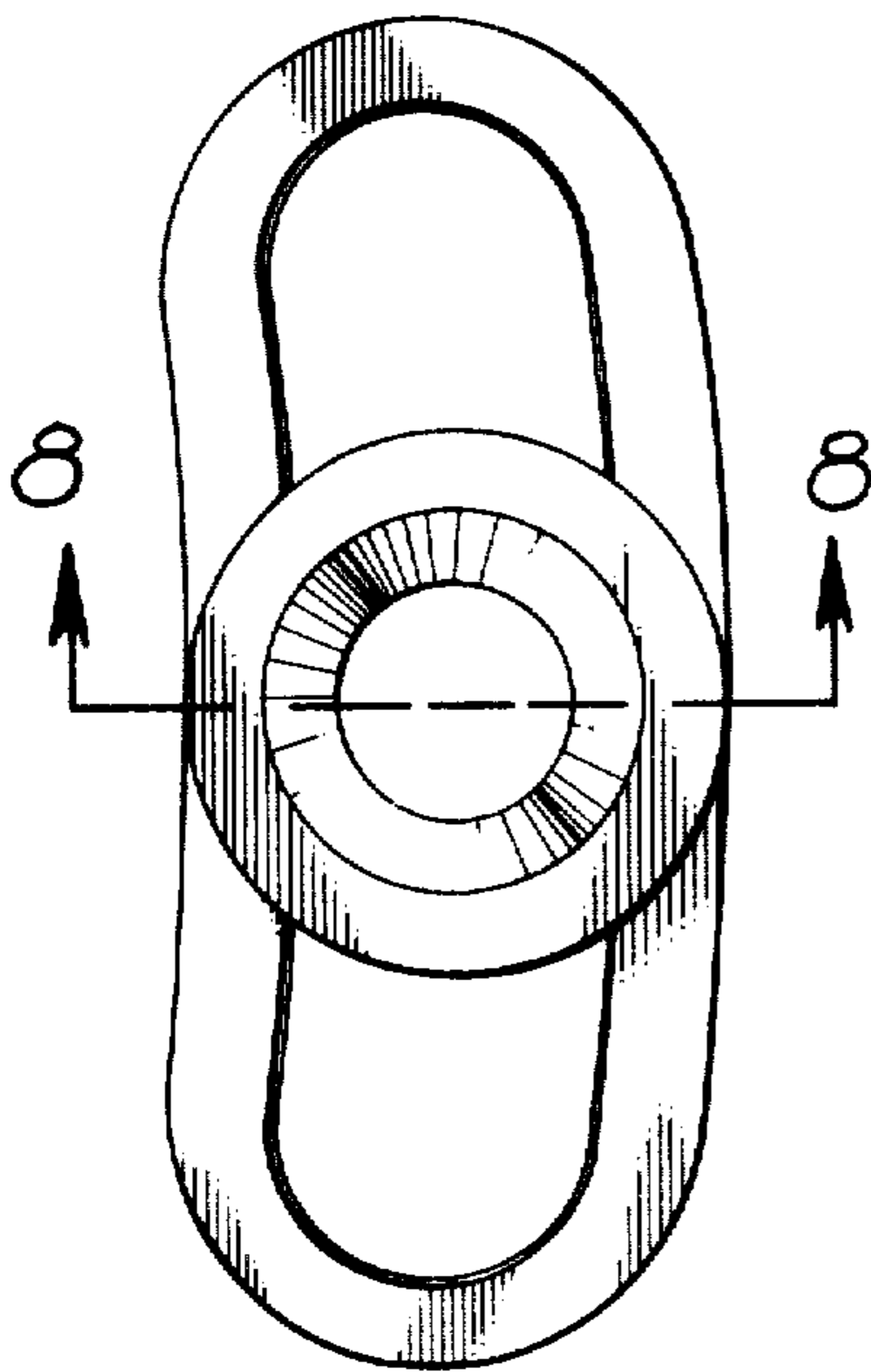

FIG - 5

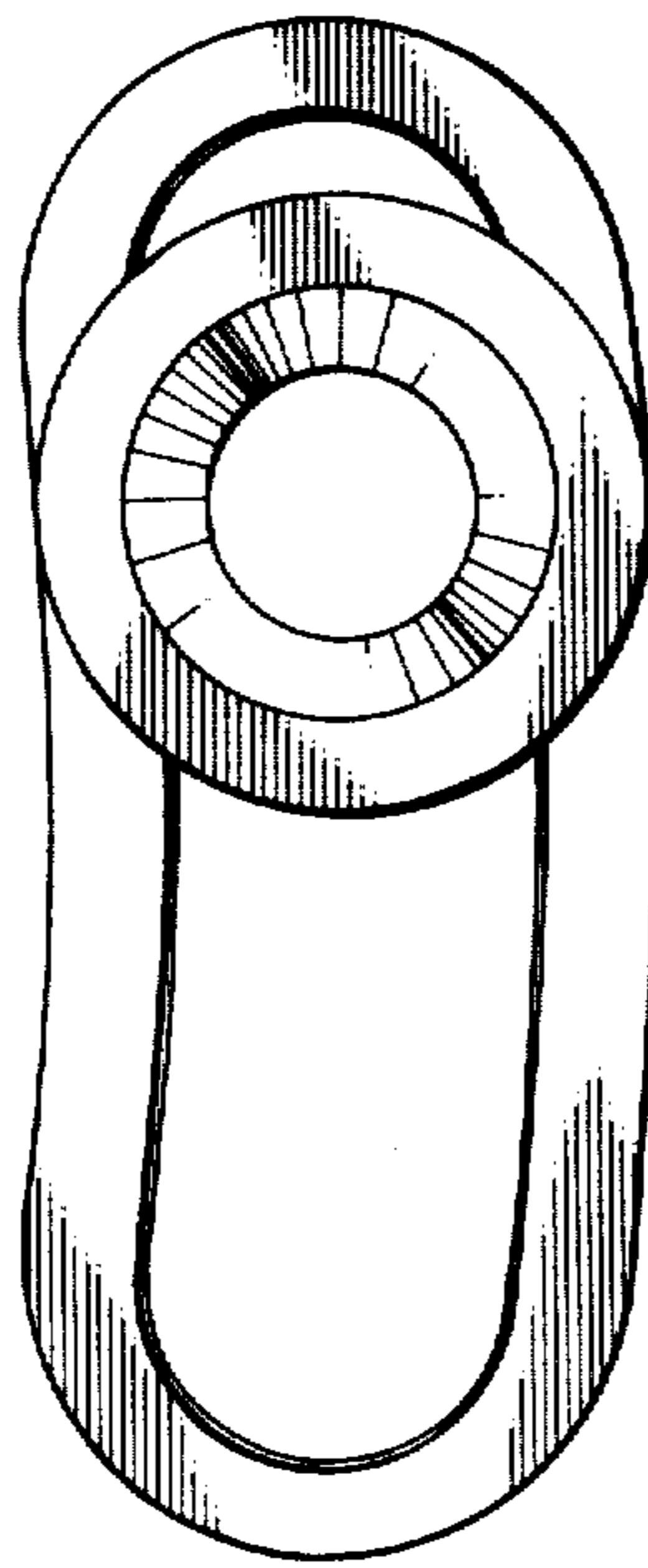

FIG - 6

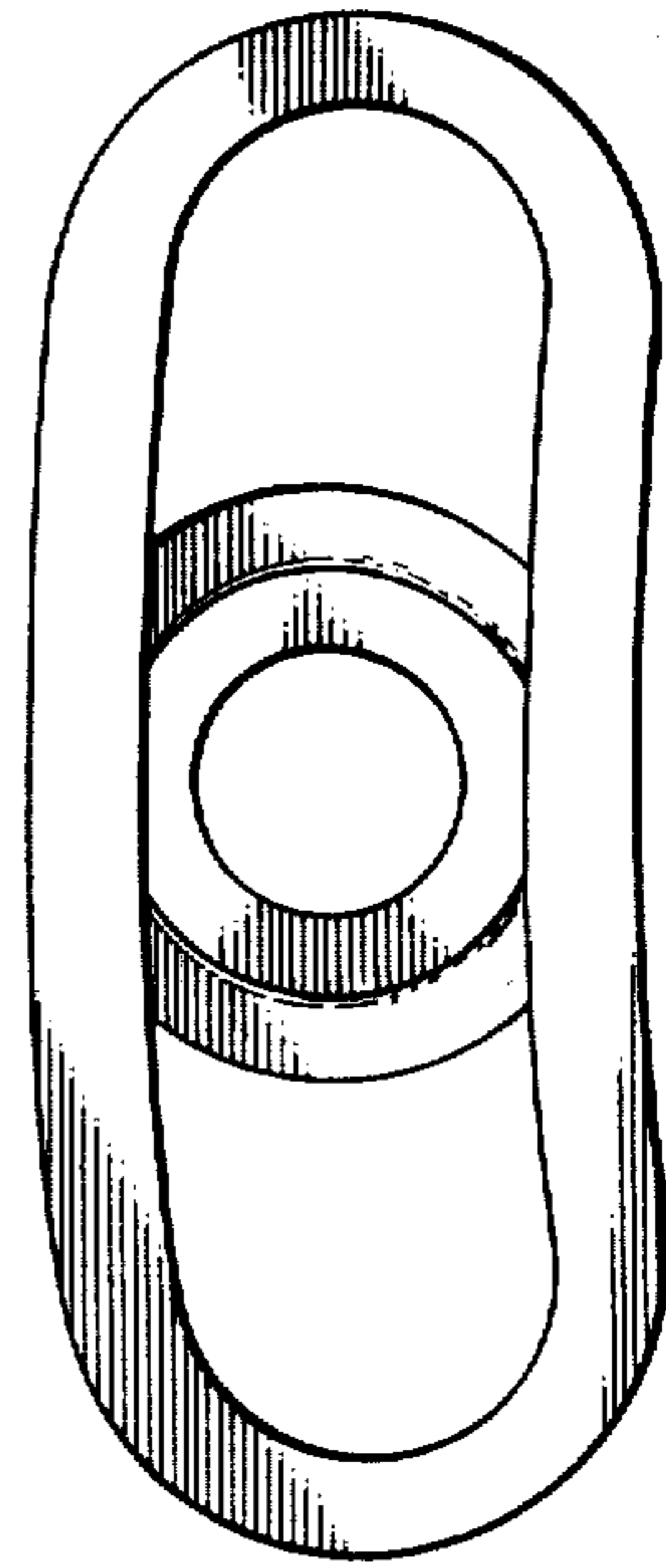

FIG - 7