

[54] TOY CAR WITH PEDAL DRIVE

[76] Inventors: Heinz Kuchenbecker, Parkstr. 17; Hans J. L. Kuchenbecker, Parkstr. 15; Rolf Kuchenbecker, Parkstr. 17, all of, D-5657 Haan 2, Fed. Rep. of Germany

[**] Term: 14 Years

[21] Appl. No.: 173,663

[22] Filed: Jul. 29, 1980

[51] Int. Cl. D12-11

[52] U.S. Cl. D12/108; D12/112; D21/78; D21/80

[58] Field of Search D12/108, 112; D21/76, D21/78, 80, 128; 296/177; 280/1.11 R, 281 LP, 281 W, 281 B, 282

[56] References Cited

U.S. PATENT DOCUMENTS

D. 215,317 9/1969 Hood D21/78

Primary Examiner—James M. Gandy

Attorney, Agent, or Firm—Ernest F. Marmorek

[57] CLAIM

The ornamental design for a toy car with pedal drive, substantially as shown and described.

DESCRIPTION

FIG. 1 is a side elevational view of a toy car with pedal drive showing our new design the opposite side being a mirror image thereof;

FIG. 2 is a top plan view thereof;

FIG. 3 is a front elevational view thereof;

FIG. 4 is a rear elevational view thereof;

FIG. 5 is a longitudinal central sectional view thereof taken on the line V—V of FIG. 2;

FIG. 6 is a sectional view, taken on the line VI—VI of FIG. 5;

FIG. 7 is an elevational view of the brake linkage, shown separately from the toy car for clarity of illustration; and

FIG. 8 is an elevational view of a second embodiment of the brake linkage which is to be positioned inside the body of the toy car, it being shown separately therefrom for clarity of illustration.

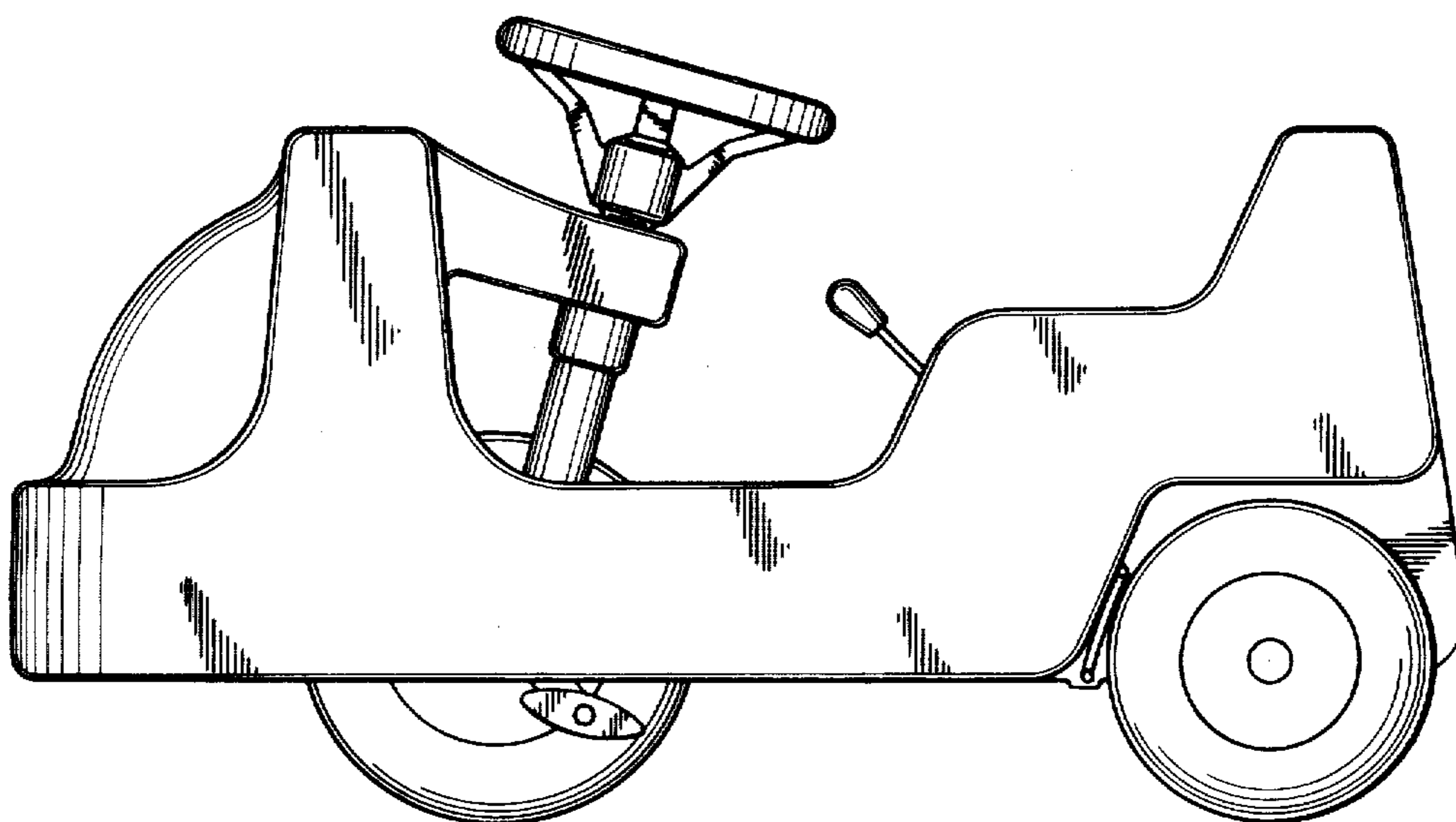

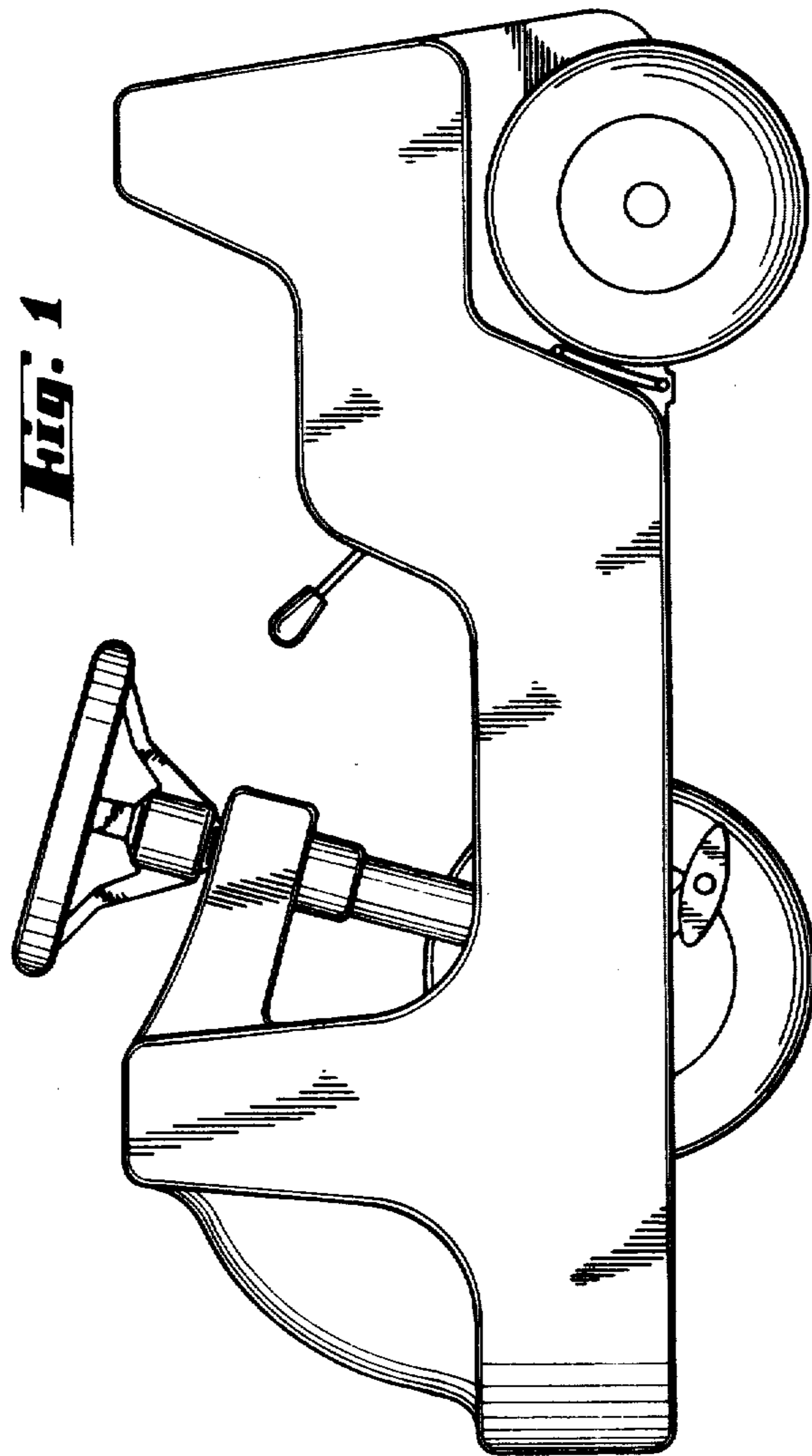

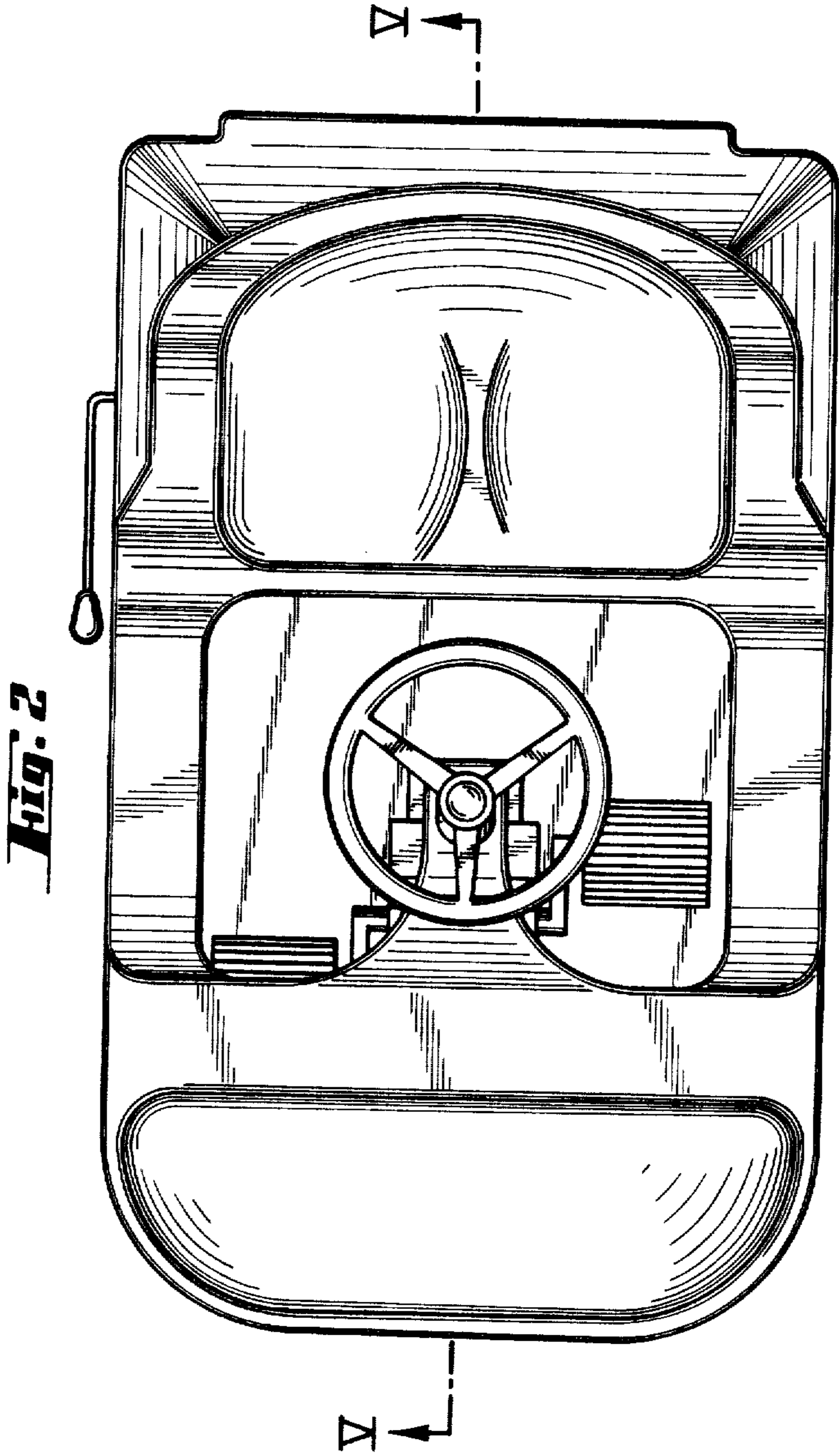

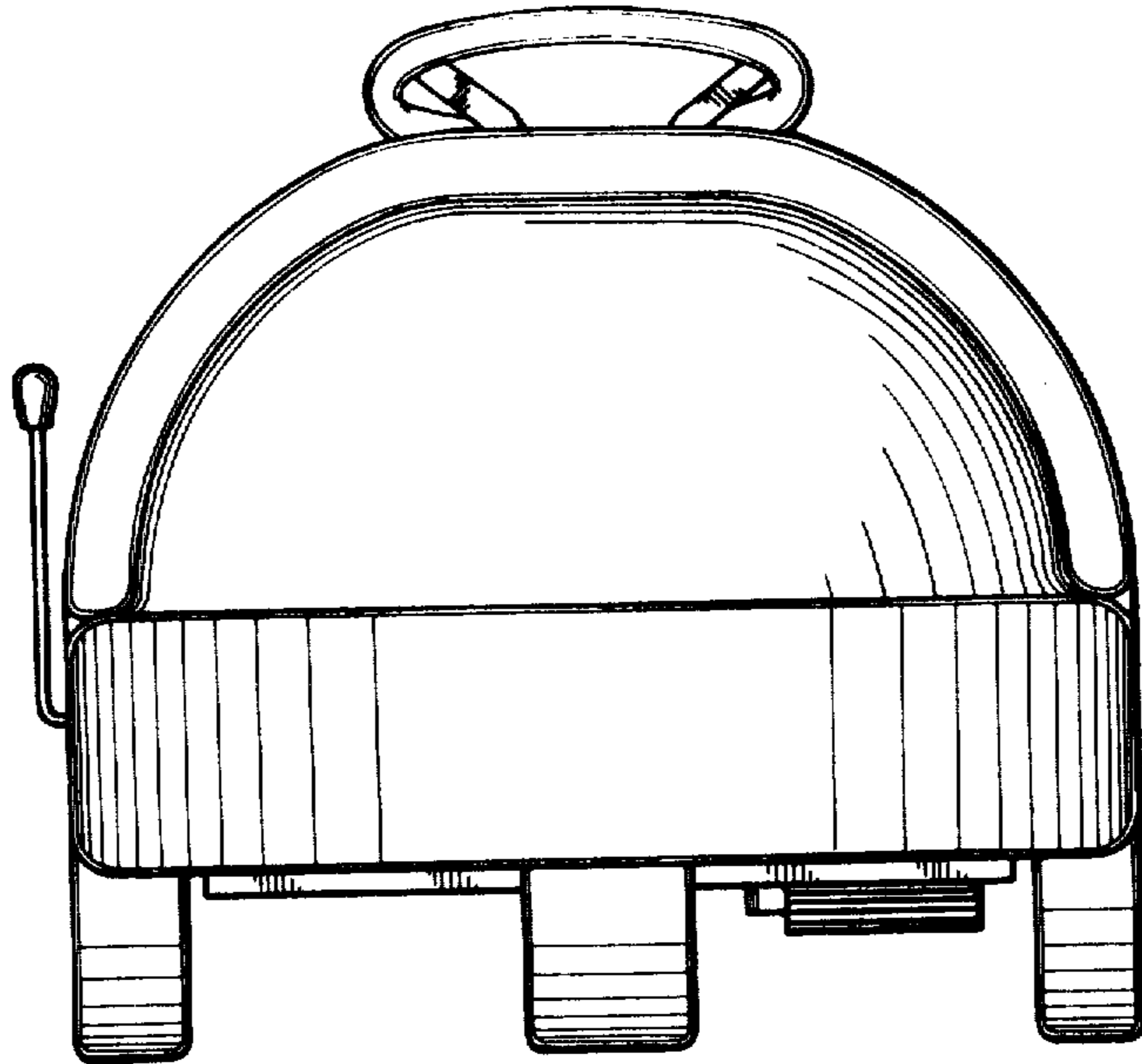

Fig. 3

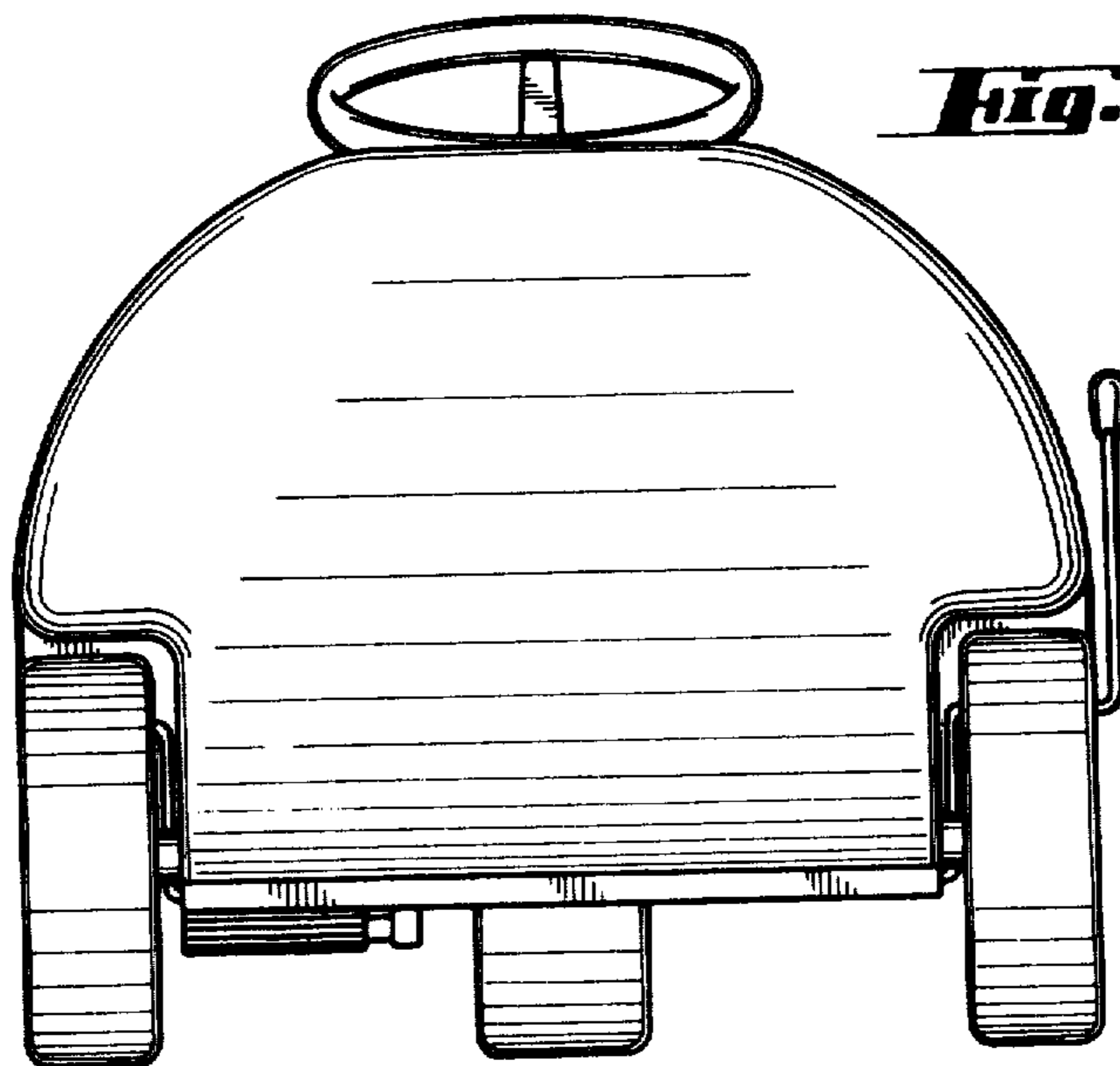

Fig. 4

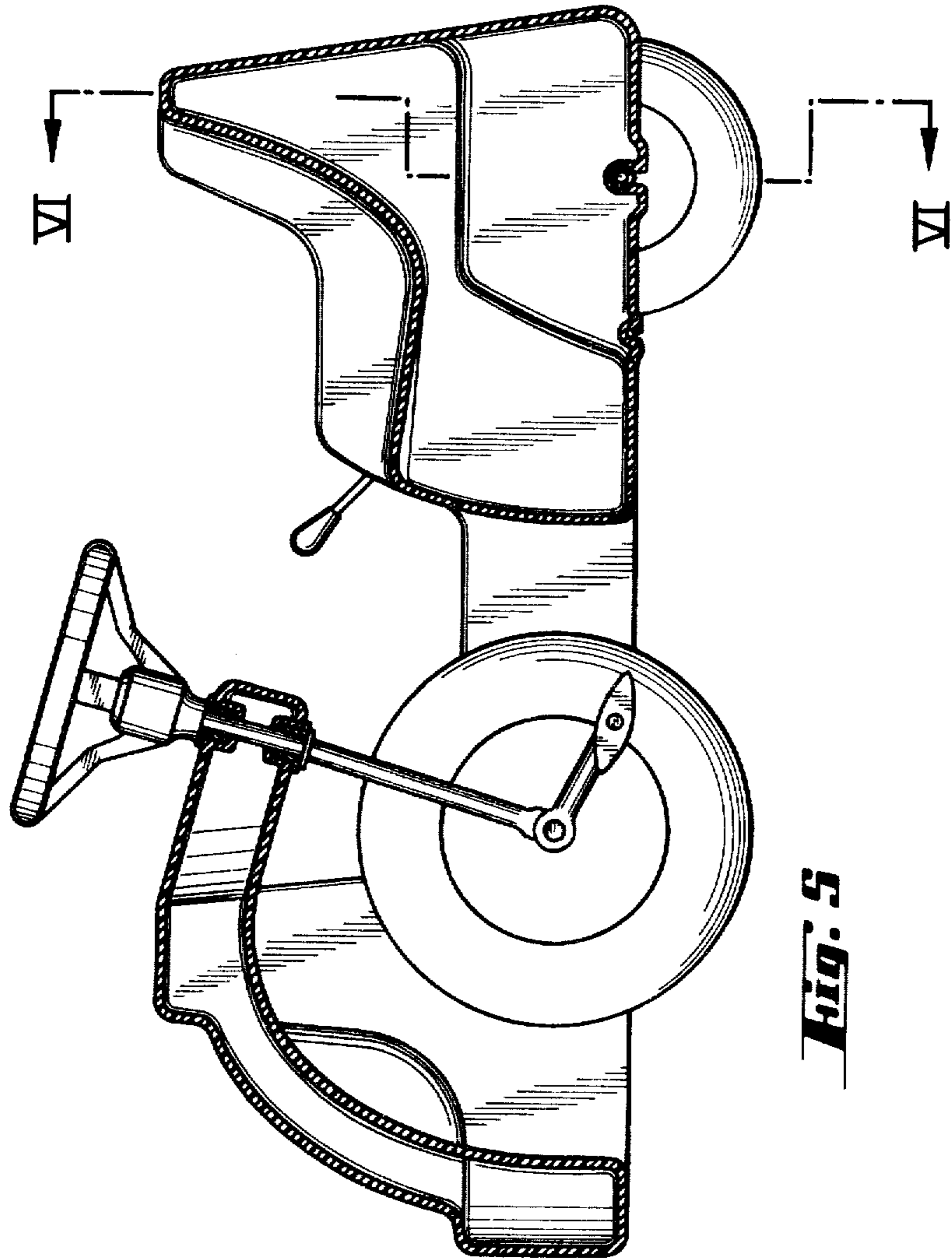

Fig. 5

Fig. 6

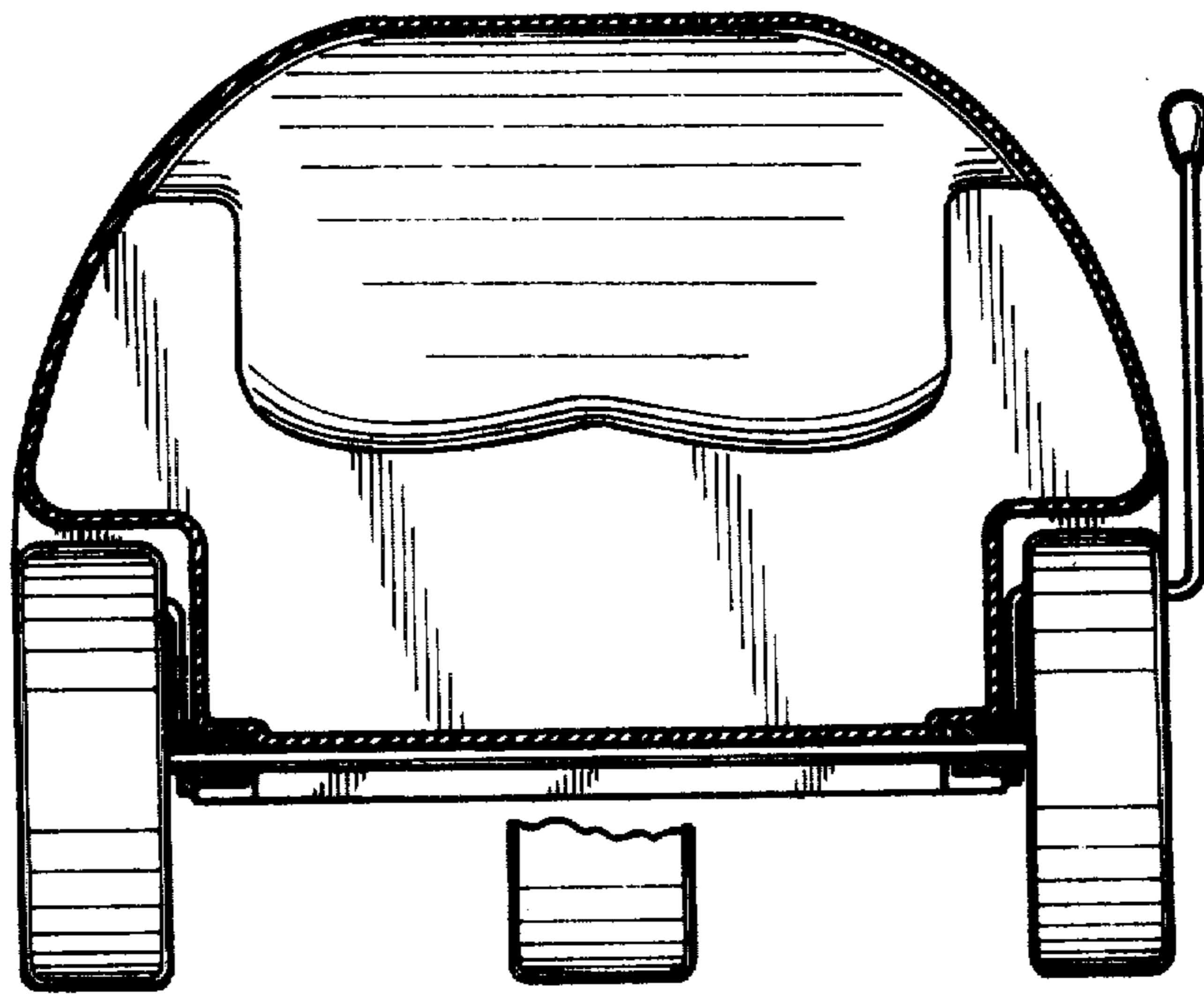

Fig. 7

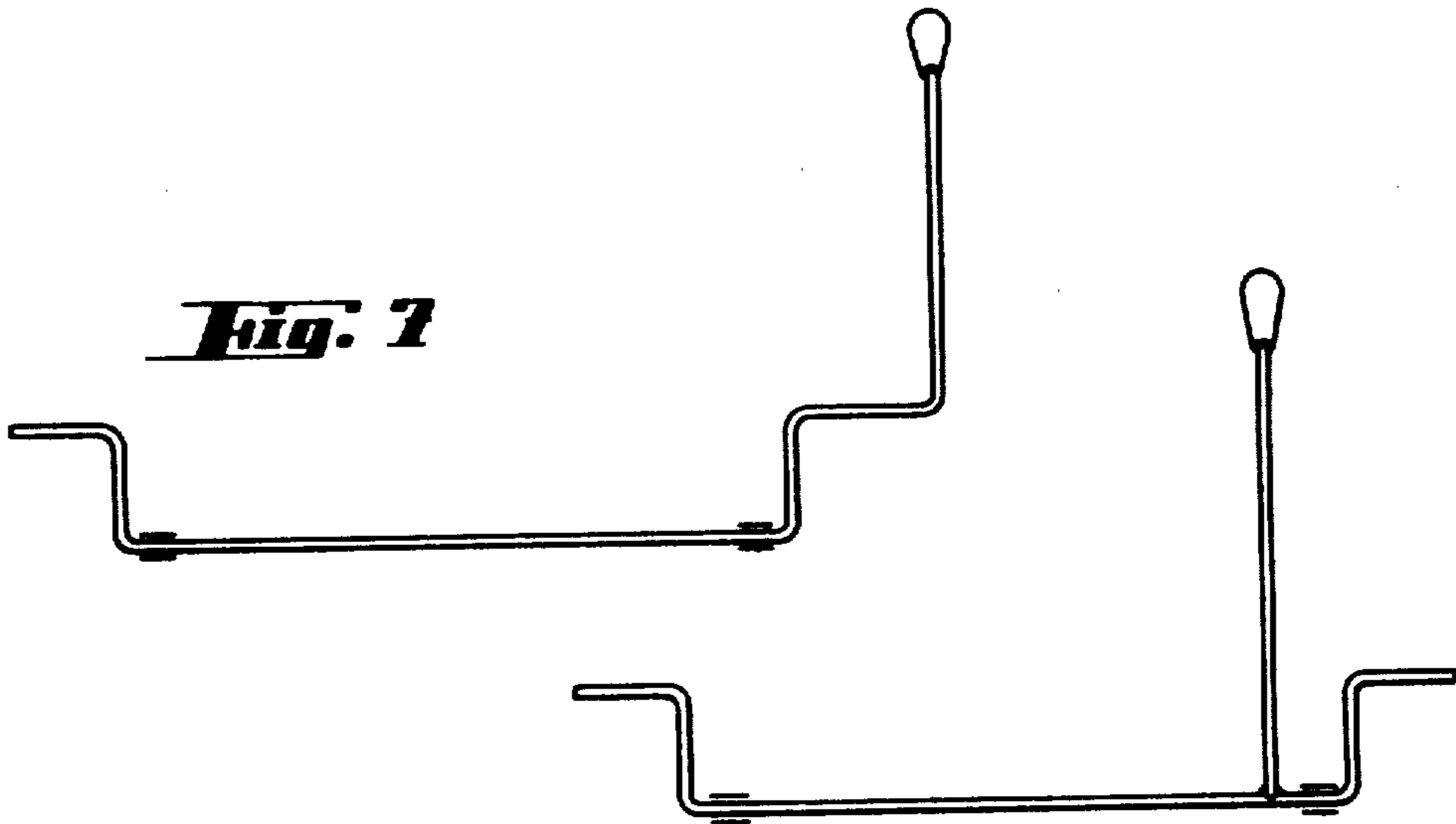

Fig. 8