

[54] **COMBINED MULTIPLE-UNIT MOTOR FUEL DISPENSER**

[76] Inventor: **Leonardus P. Koppens**, Industrieweg 5, 5531 AD Bladel, Netherlands

[**] Term: **14 Years**

[21] Appl. No.: **361,100**

[22] Filed: **Mar. 23, 1982**

[30] **Foreign Application Priority Data**
 Sep. 23, 1981 [XB] Benelux 56104-00

[51] Int. Cl. **D15-02**

[52] U.S. Cl. **D15/9.2**

[58] Field of Search **D15/9.1, 9.2, 9.3; 222/25-28, 32-37, 75, 530**

[56] **References Cited**

U.S. PATENT DOCUMENTS

D. 181,354 11/1957 Greene D15/9.2

D. 244,563 5/1977 Taylor D15/9.1

D. 262,115 12/1981 Rowan D15/9.2

D. 262,970 2/1982 Rowan D15/9.2

D. 262,971 2/1982 Robinson D15/9.2

D. 264,471 5/1982 Rowan D15/9.2

D. 265,092 6/1982 Robinson D15/9.2

3,033,421 5/1962 Henderson 222/26

3,199,727 8/1965 Romanowski 222/26 X

3,692,212 9/1972 Irie 222/32

3,797,703 3/1974 Yamawaki 222/26

Primary Examiner—Nelson C. Holtje
Attorney, Agent, or Firm—Cushman, Darby & Cushman

[57] **CLAIM**

The ornamental design for a combined multiple-unit motor fuel dispenser, as shown and described.

DESCRIPTION

FIG. 1 is a left end elevational view of a combined multiple-unit motor fuel dispenser showing my new design;

FIG. 2 is a front elevational view thereof;

FIG. 3 is a right end elevational view thereof; and

FIG. 4 is a top plan view as taken from line 4-4 of FIG. 2.

The rear view is a mirror image of FIG. 2, and the top and bottom surfaces are flat, plain and unornamented.

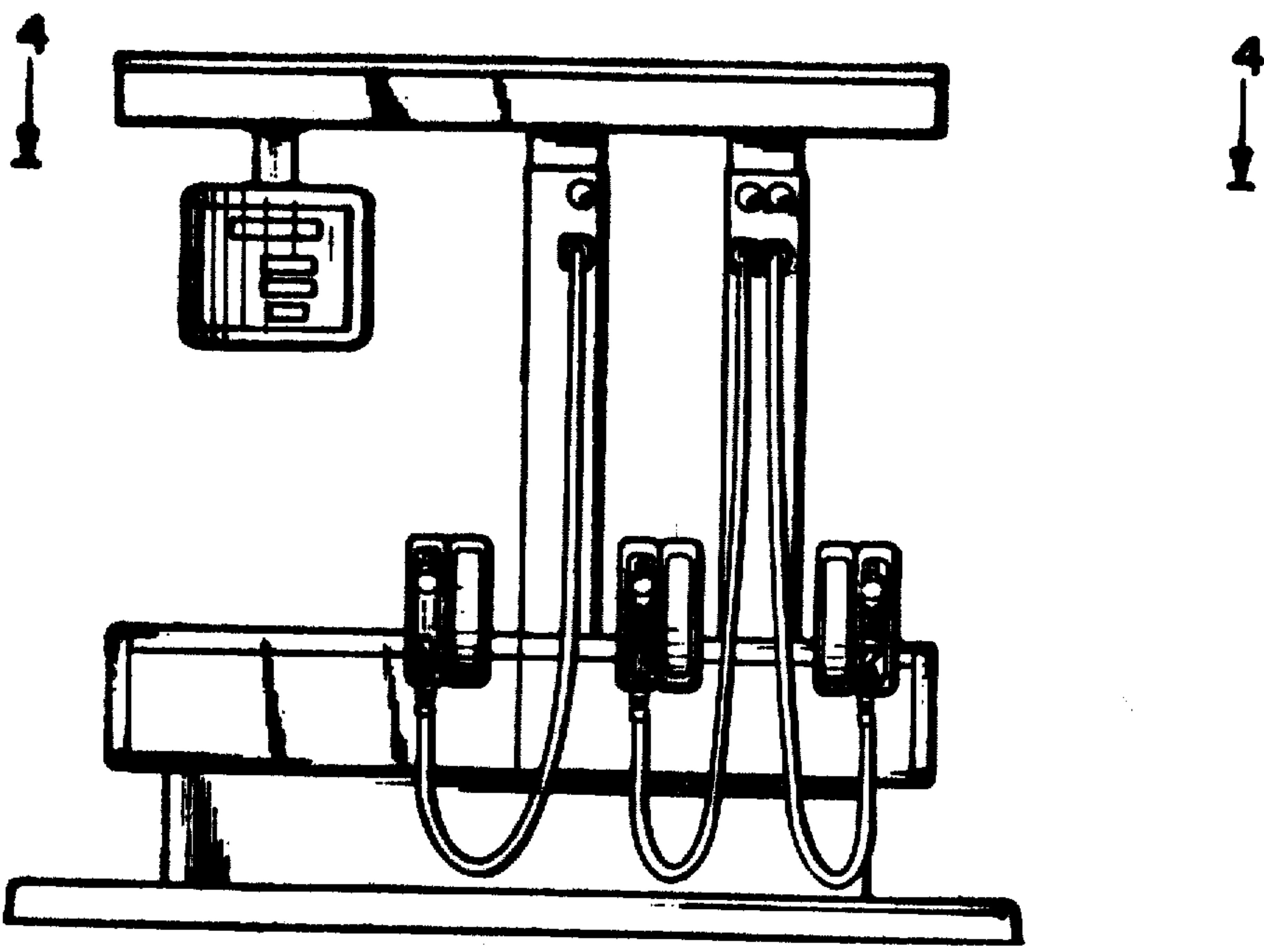

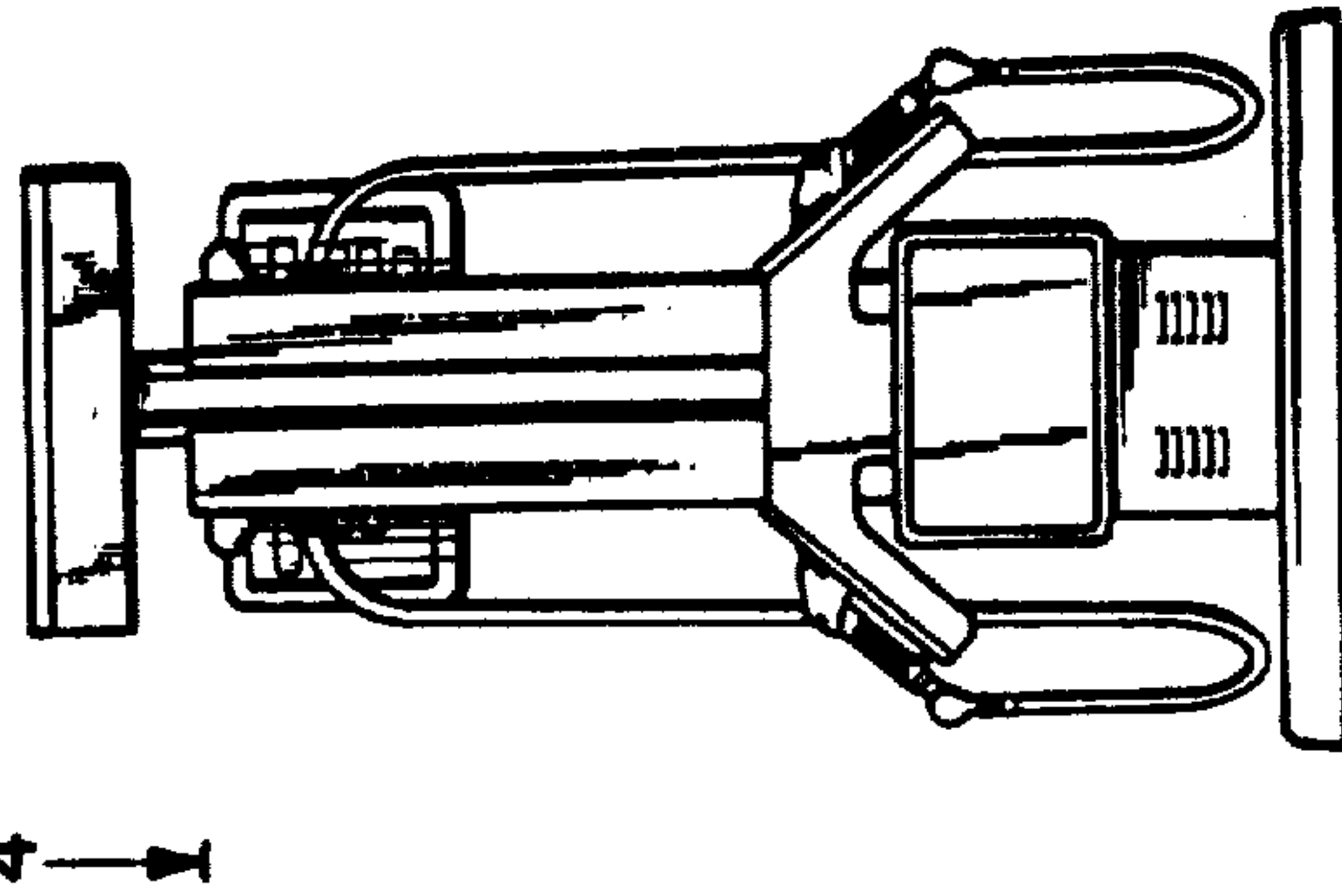

FIG. 3

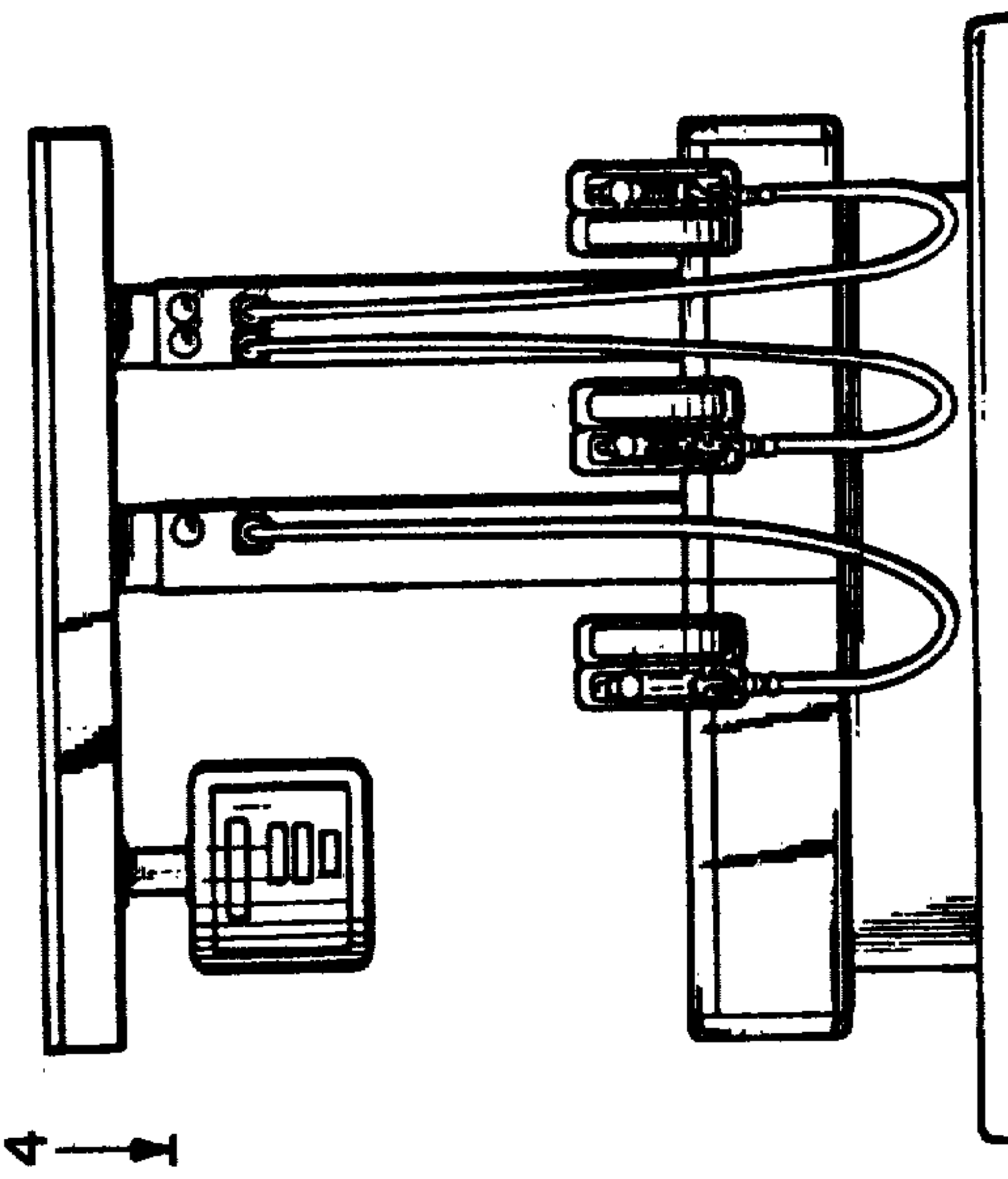

FIG. 2

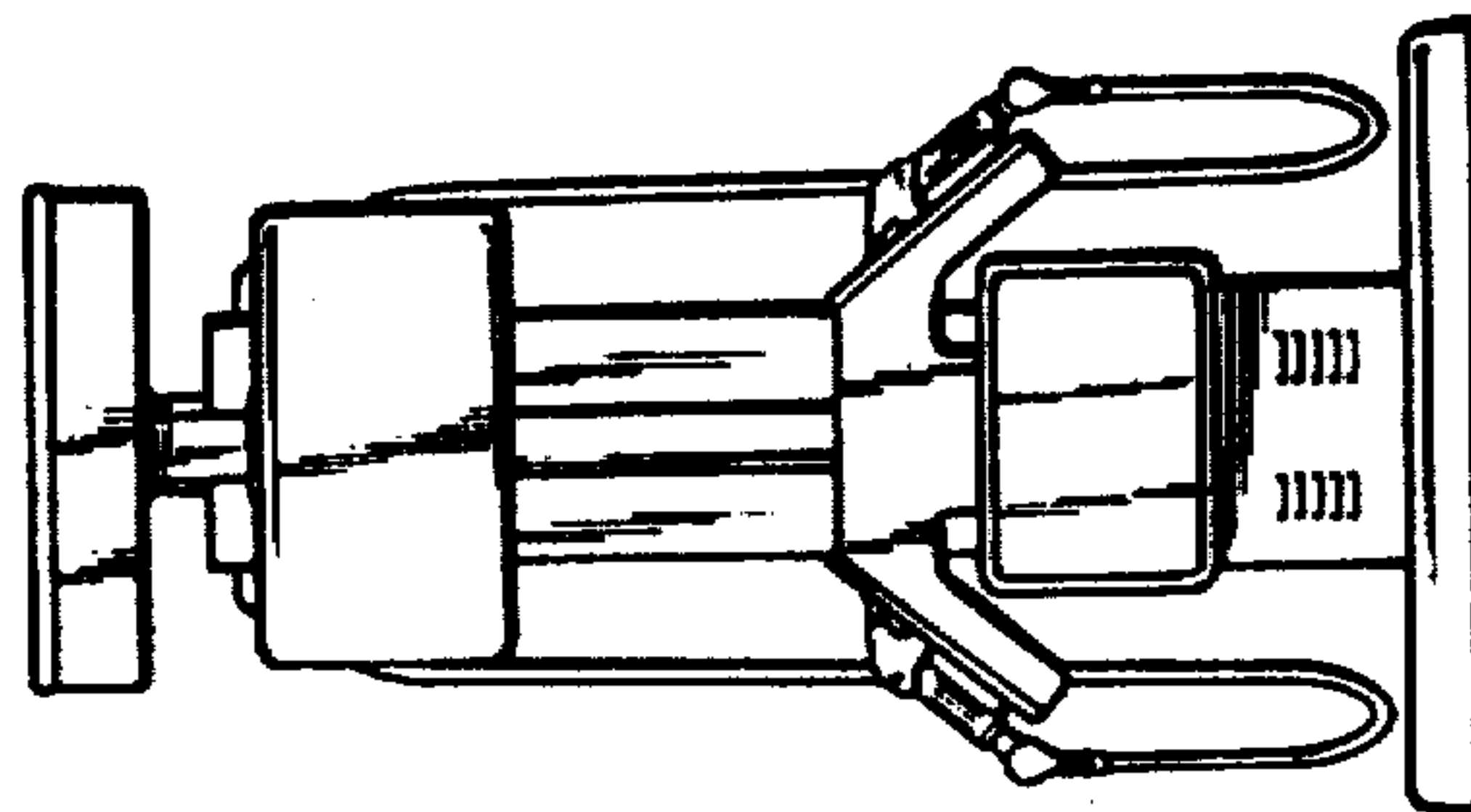

FIG. 1

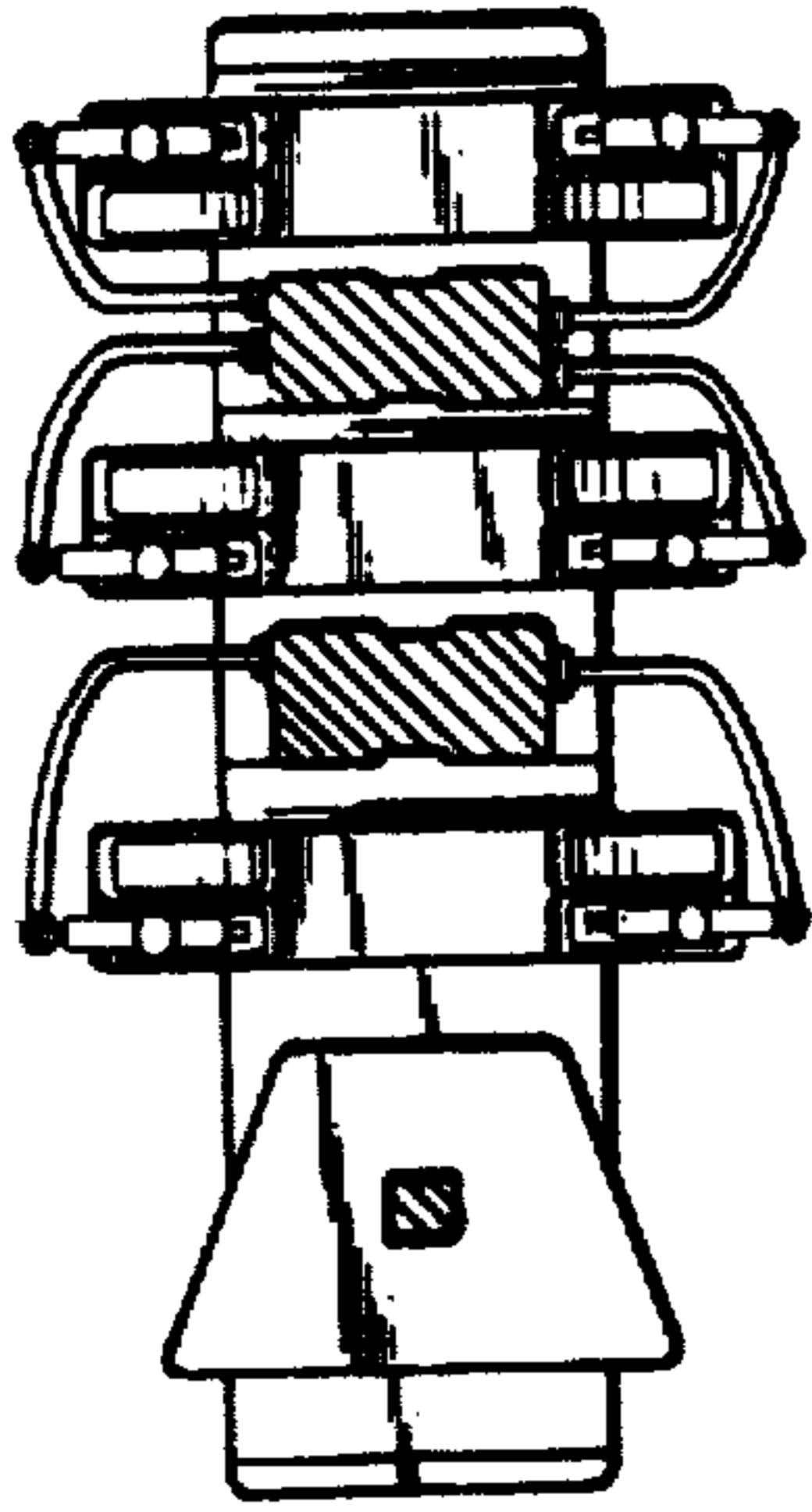

FIG. 4