

[54] FAIRING FOR MOTOR TRICYCLE

[75] Inventor: Jun Ito, Tokyo, Japan
[73] Assignee: Honda Giken Kogyo Kabushiki Kaisha, Tokyo, Japan
[**] Term: 14 Years
[21] Appl. No.: 301,865
[22] Filed: Sep. 14, 1981
[30] Foreign Application Priority Data

Mar. 13, 1981 [JP] Japan 56-10241

[51] Int. Cl. D12-11
[52] U.S. Cl. D12/182
[58] Field of Search D12/182; 296/78.1

[56] References Cited

U.S. PATENT DOCUMENTS

D. 257,838 1/1981 Mockett D12/182

D. 258,127 2/1981 Kamata D12/182

OTHER PUBLICATIONS

Cycle, 6/79, p. 59, Fairing on Moto Guzzi Motorcycle.

Primary Examiner—James M. Gandy
Attorney, Agent, or Firm—Sughrue, Mion, Zinn, Macpeak & Seas

[57] CLAIM

The ornamental design for a fairing for motor tricycle, as shown and described.

DESCRIPTION

FIG. 1 is a front and right side perspective view of a fairing for a motor tricycle showing my new design; FIG. 2 is a front elevational view thereof; FIG. 3 is a top plan view thereof; FIG. 4 is a left side elevational view thereof; FIG. 5 is a rear elevational view thereof; and FIG. 6 is a bottom plan view thereof.

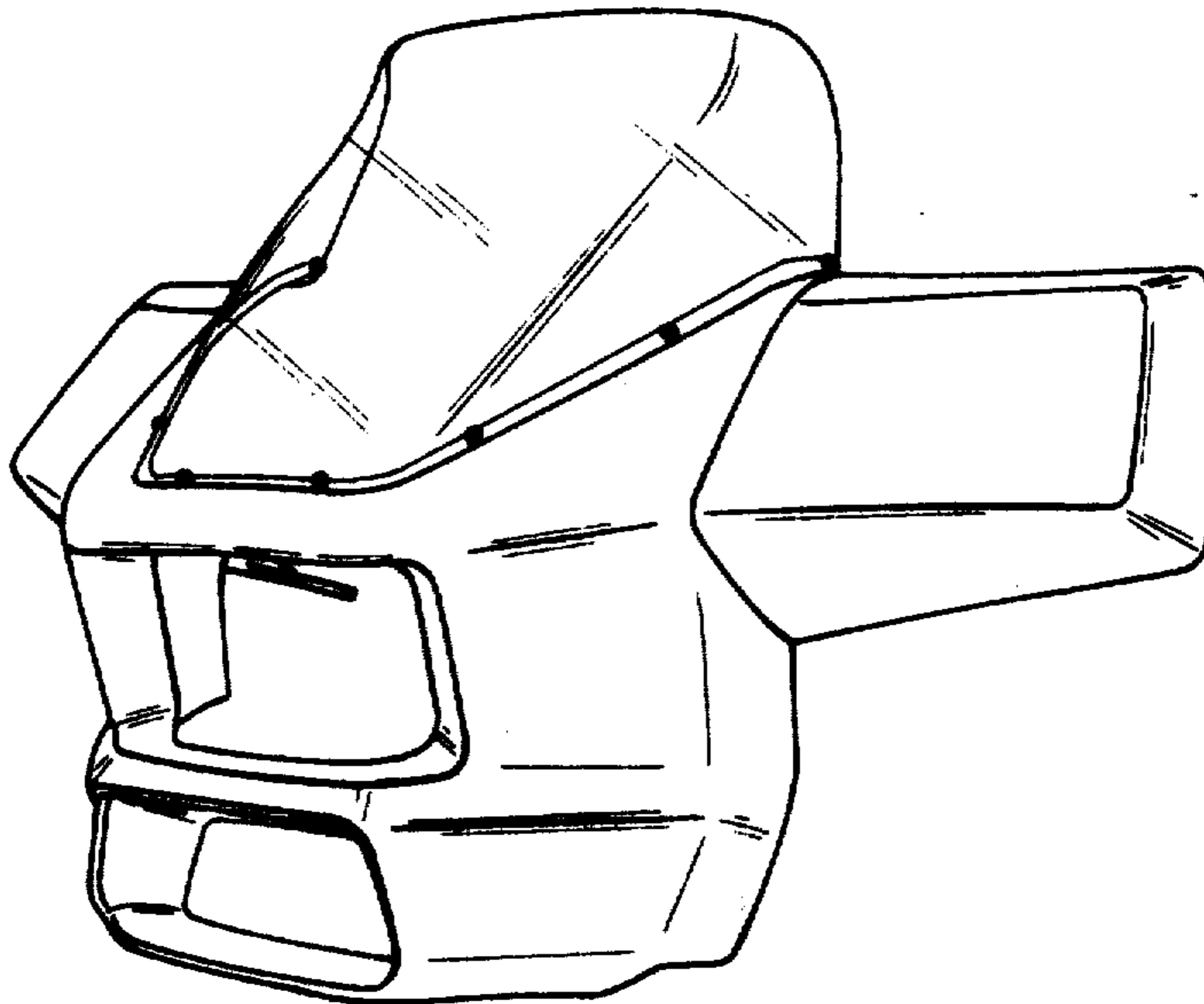

FIG. 1

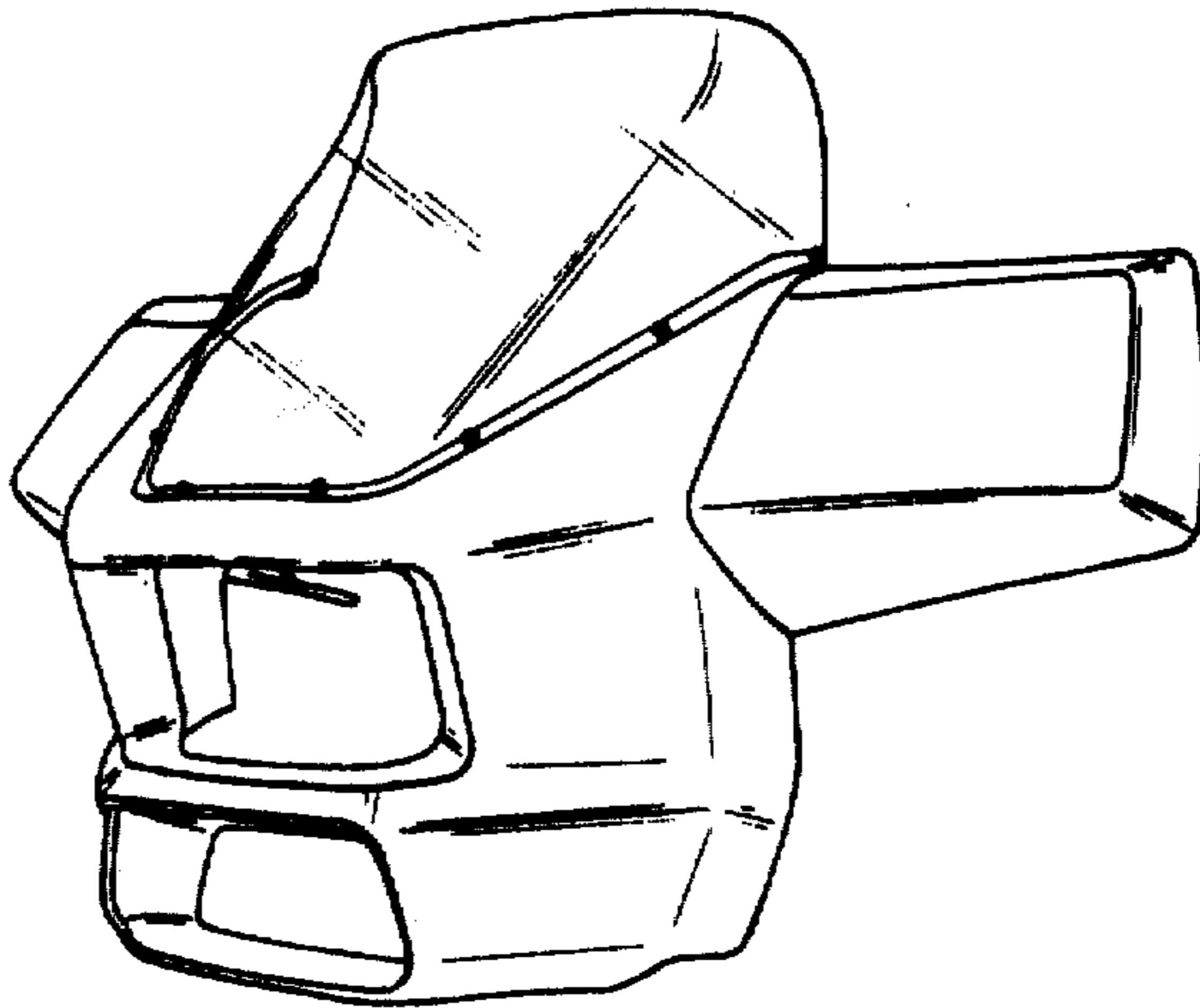

FIG. 2

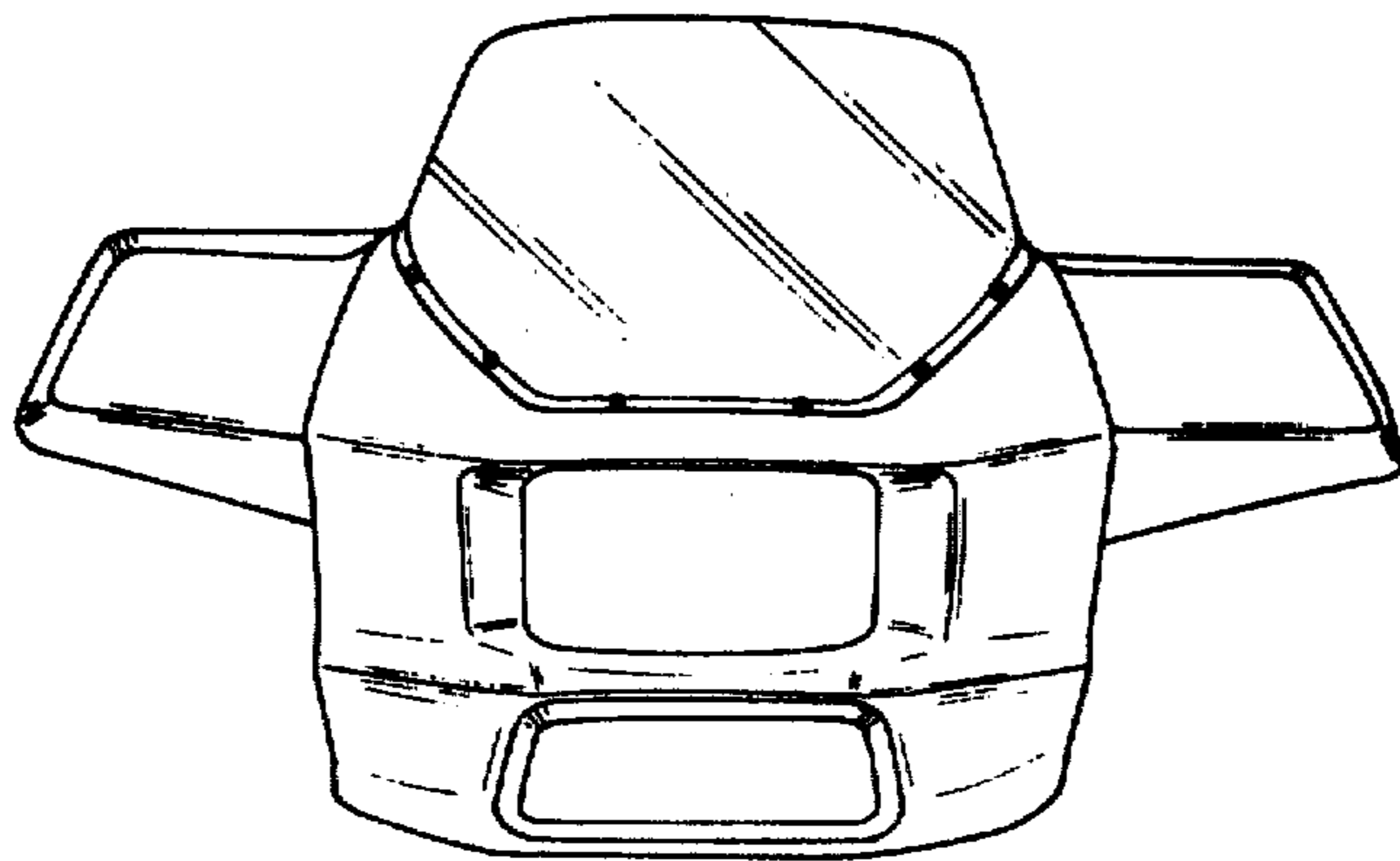

FIG. 3

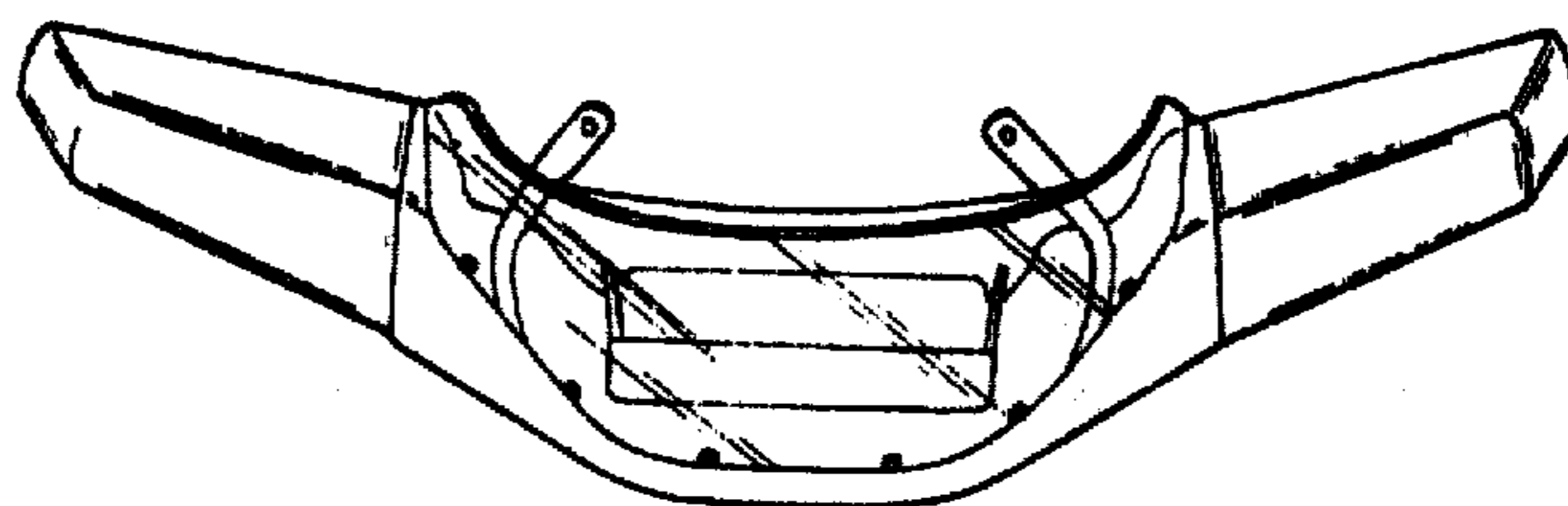

FIG. 4

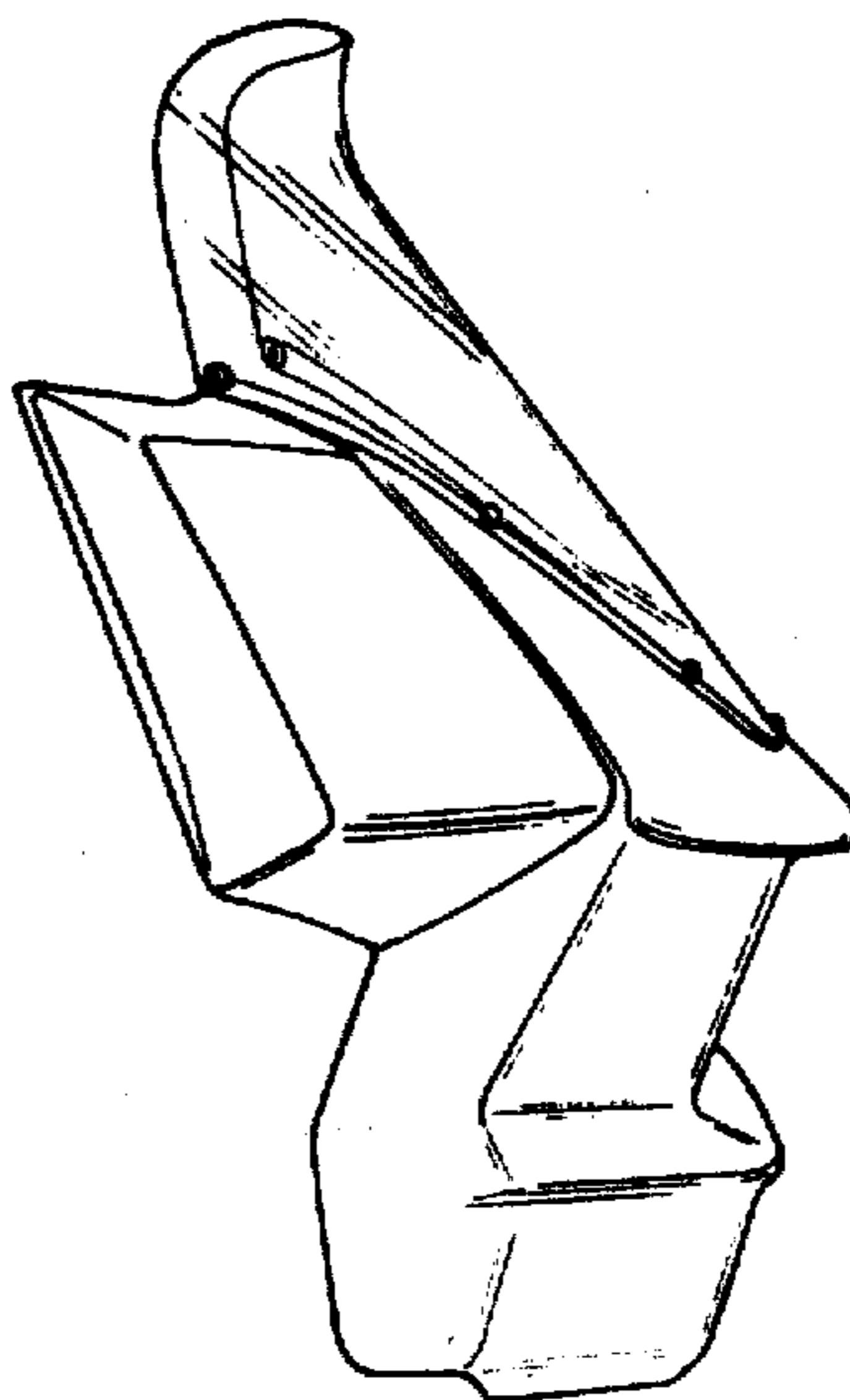

FIG. 5

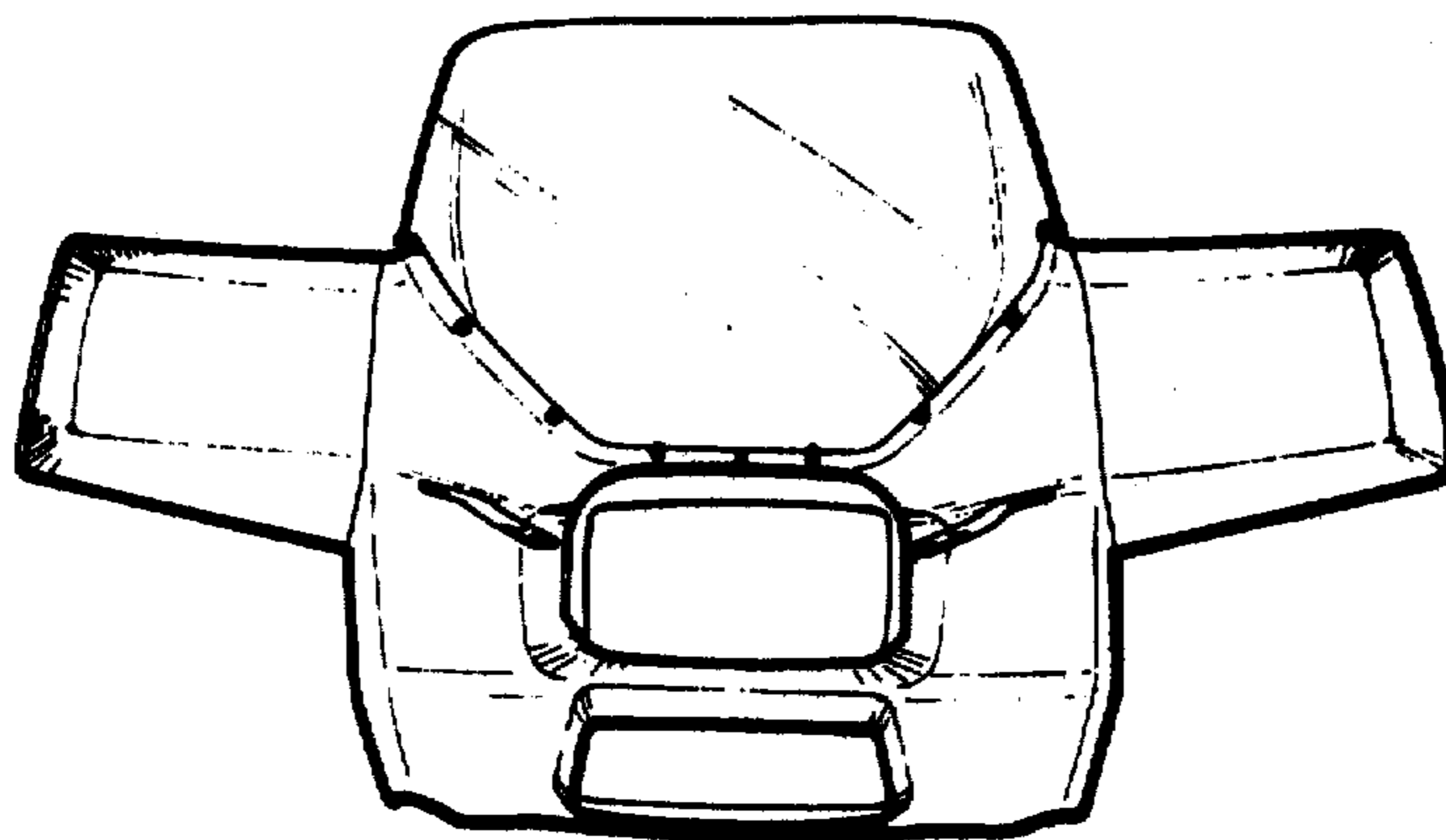

FIG. 6

