

[54] AIR TRANSPORTABLE BUS

[75] Inventor: Paul Legueu, Pornichet, France

[73] Assignee: Ateliers de Constructions Mecanizues de L'Atlantique Acmat, Saint Nazaire, France

[**] Term: 14 Years

[21] Appl. No.: 189,912

[22] Filed: Sep. 23, 1980

[30] Foreign Application Priority Data

Mar. 25, 1980 [FR] France 800967

[51] Int. Cl. D12-08

[52] U.S. Cl. D12/84

[58] Field of Search D12/84; 296/178, 179

[56] References Cited

U.S. PATENT DOCUMENTS

D. 253,763 12/1979 Legueu D12/173
1,958,234 5/1934 Cleveland 296/178

OTHER PUBLICATIONS

Commercial Car Journal, 3/80, p. 132, Bus shown in box 1, center left side of page.

Commercial Car Journal, 1/80, p. 114, Transette, upper right side of page.

Primary Examiner—James M. Gandy

Attorney, Agent, or Firm—Fidelman, Wolffe & Waldron

[57] CLAIM

The ornamental design for an air transportable bus, substantially as shown and described.

DESCRIPTION

FIG. 1 is a right front perspective view of an air transportable bus showing my new design;

FIG. 2 is a left rear perspective view thereof;

FIG. 3 is a right side elevational view of an air transportable bus showing a second embodiment of my new design;

FIG. 4 is a rear elevational view of FIG. 3;

FIG. 5 is a left side elevational view of FIG. 3; and

FIG. 6 is a front elevational view of FIG. 3.

The top of the bus is understood to be substantially unornamented.

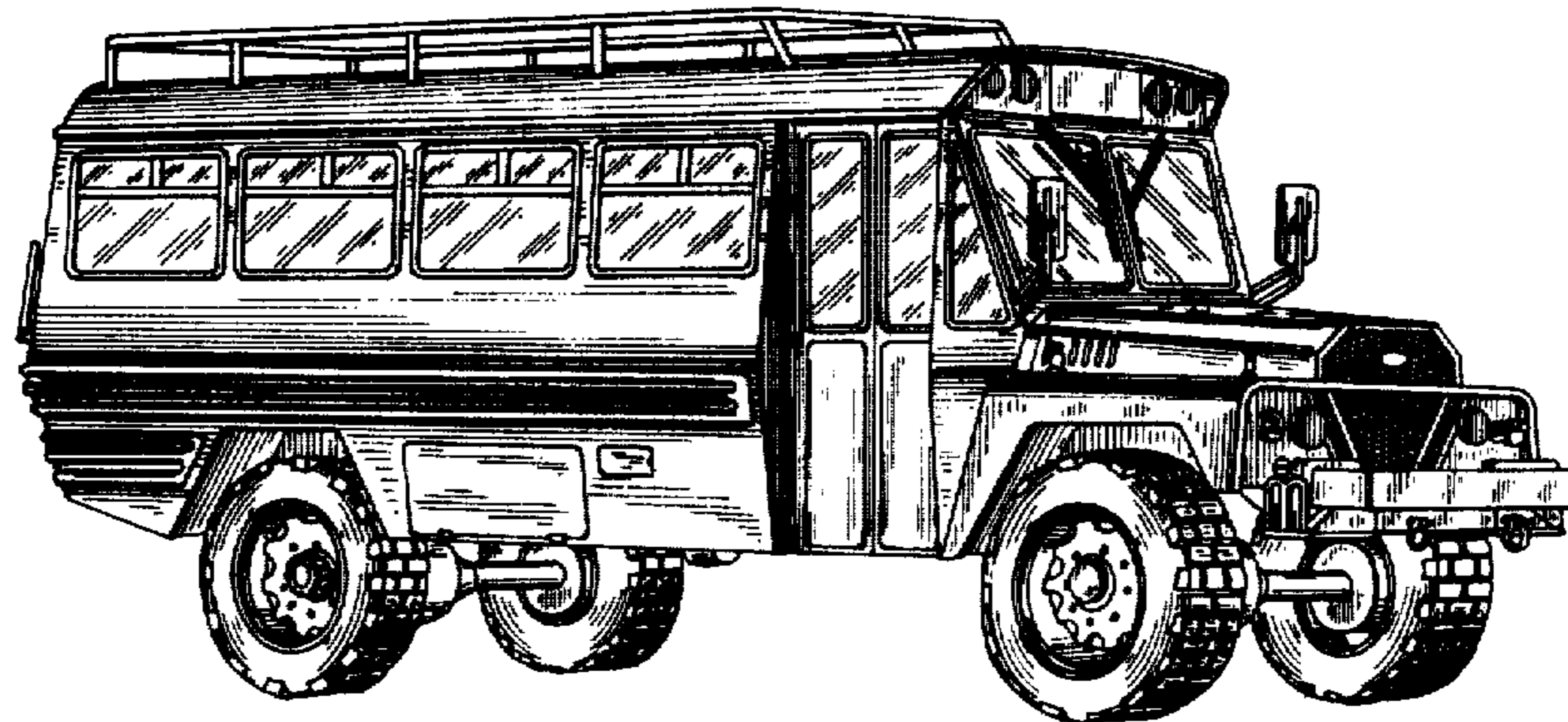

Fig. 1

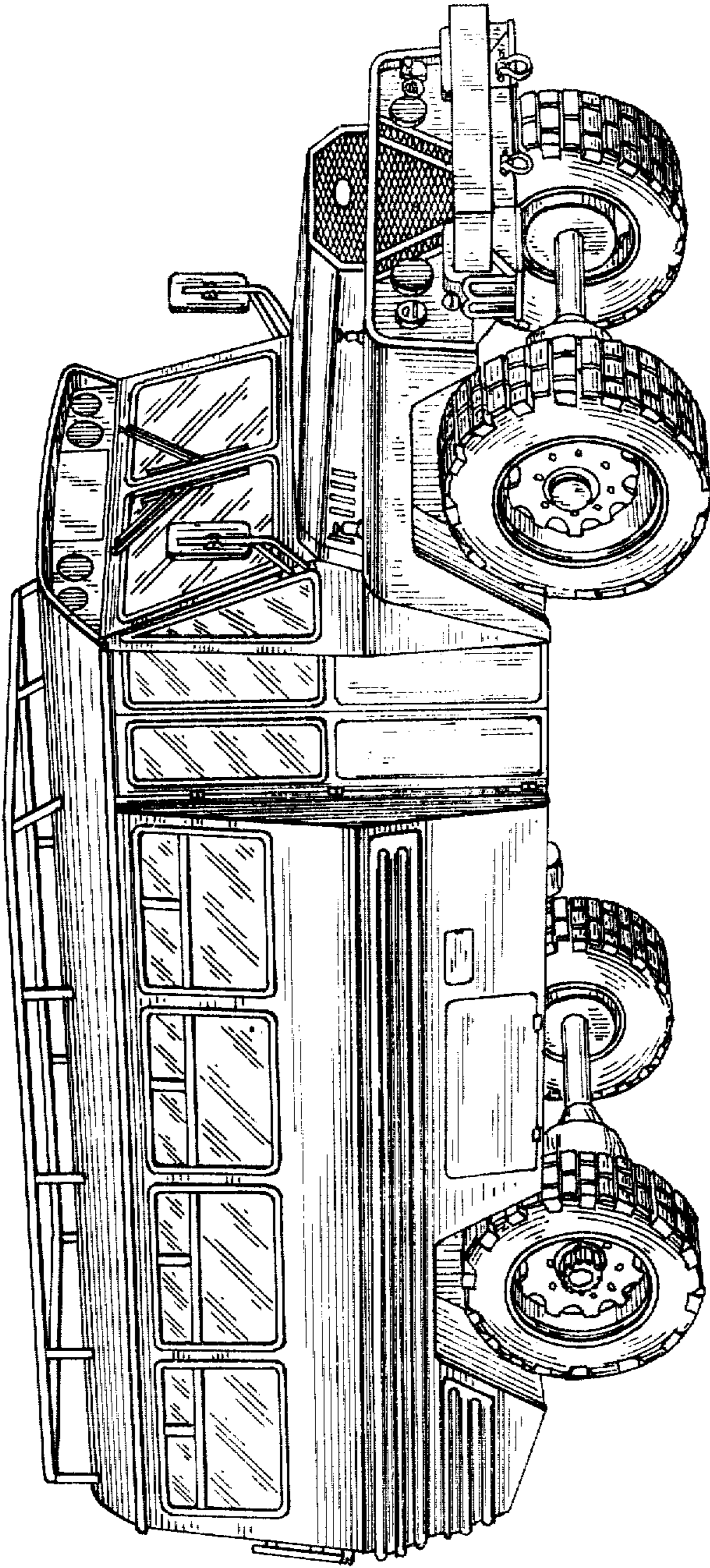

Fig. 2

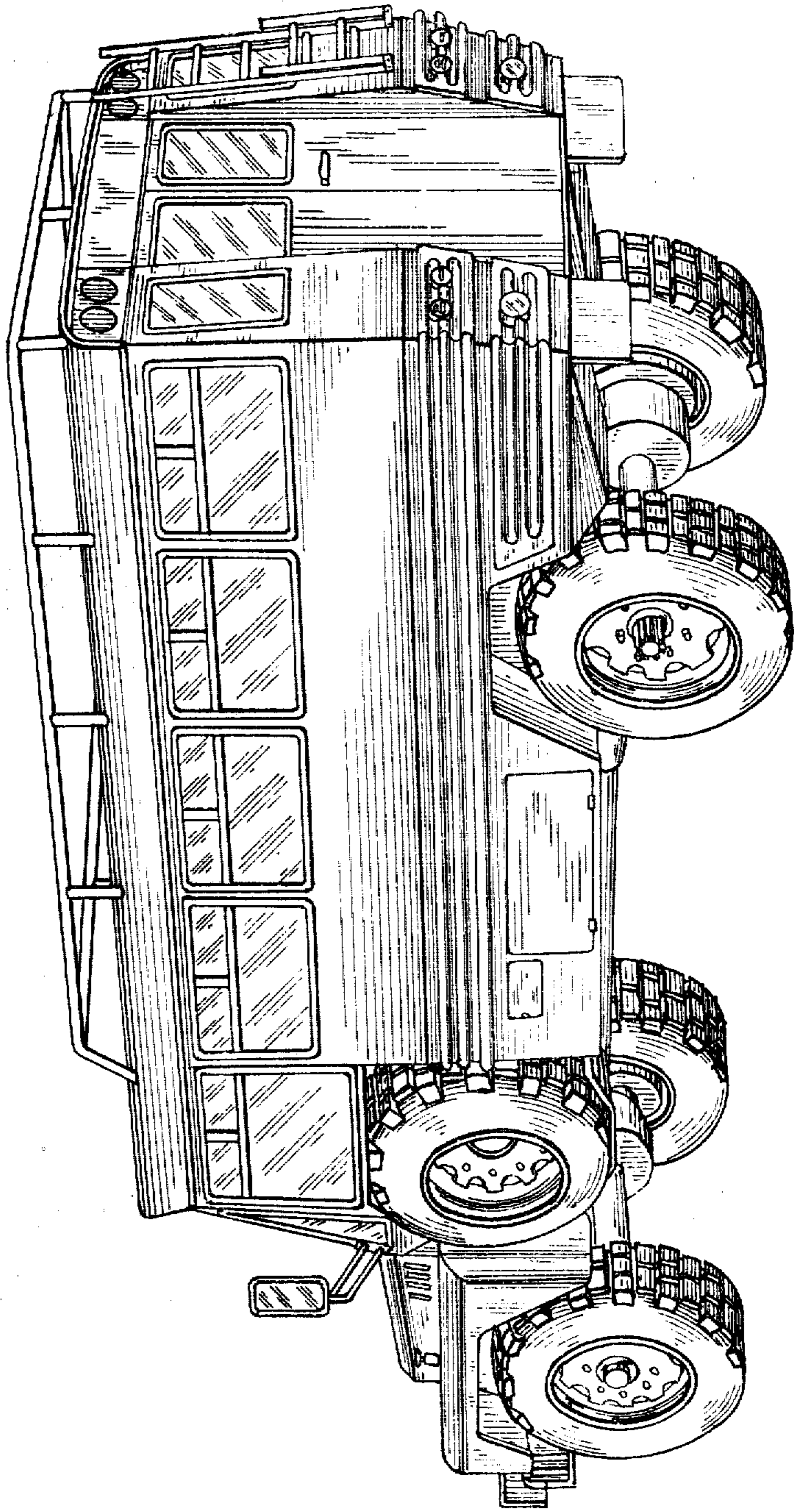

Fig. 4

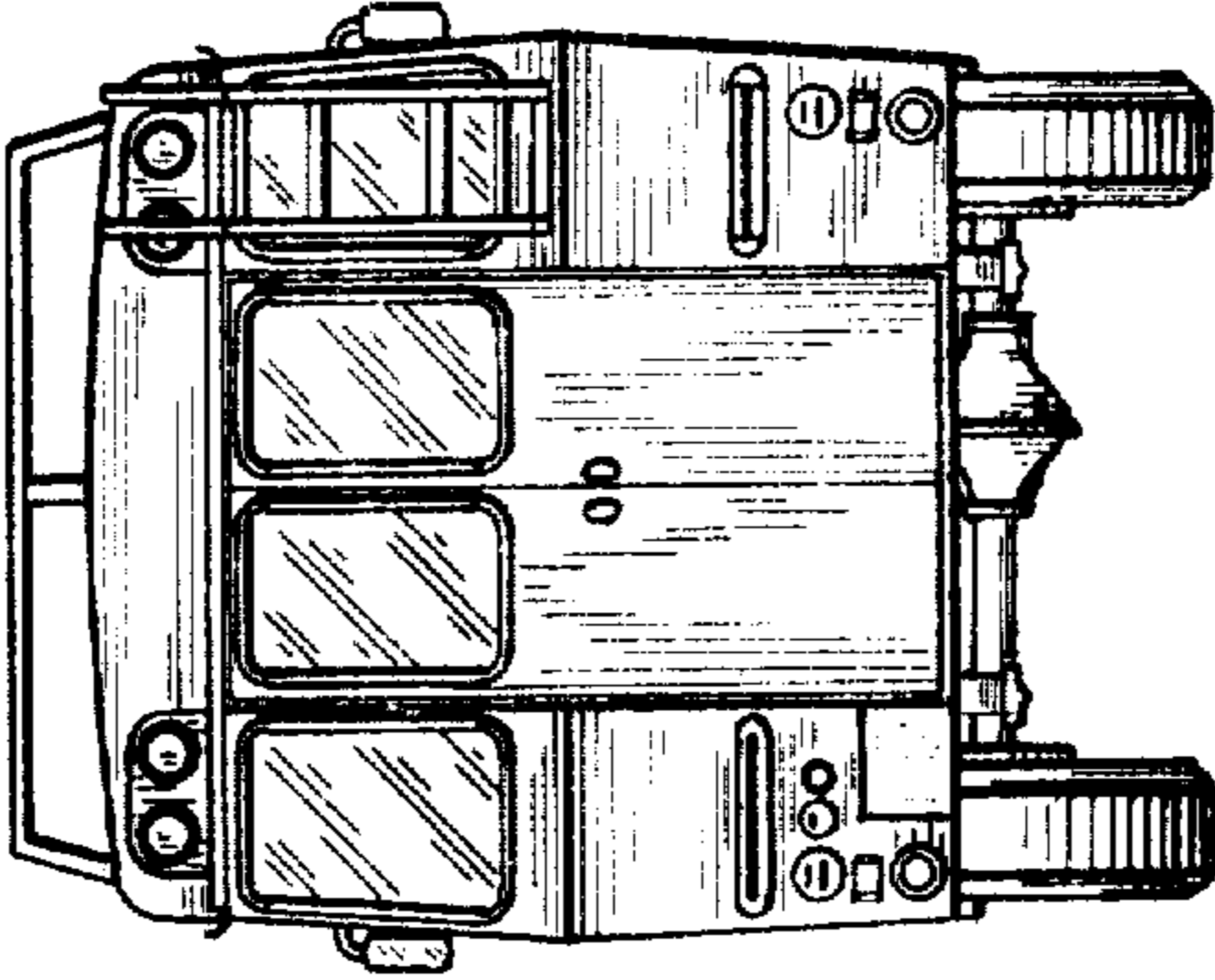

Fig. 3

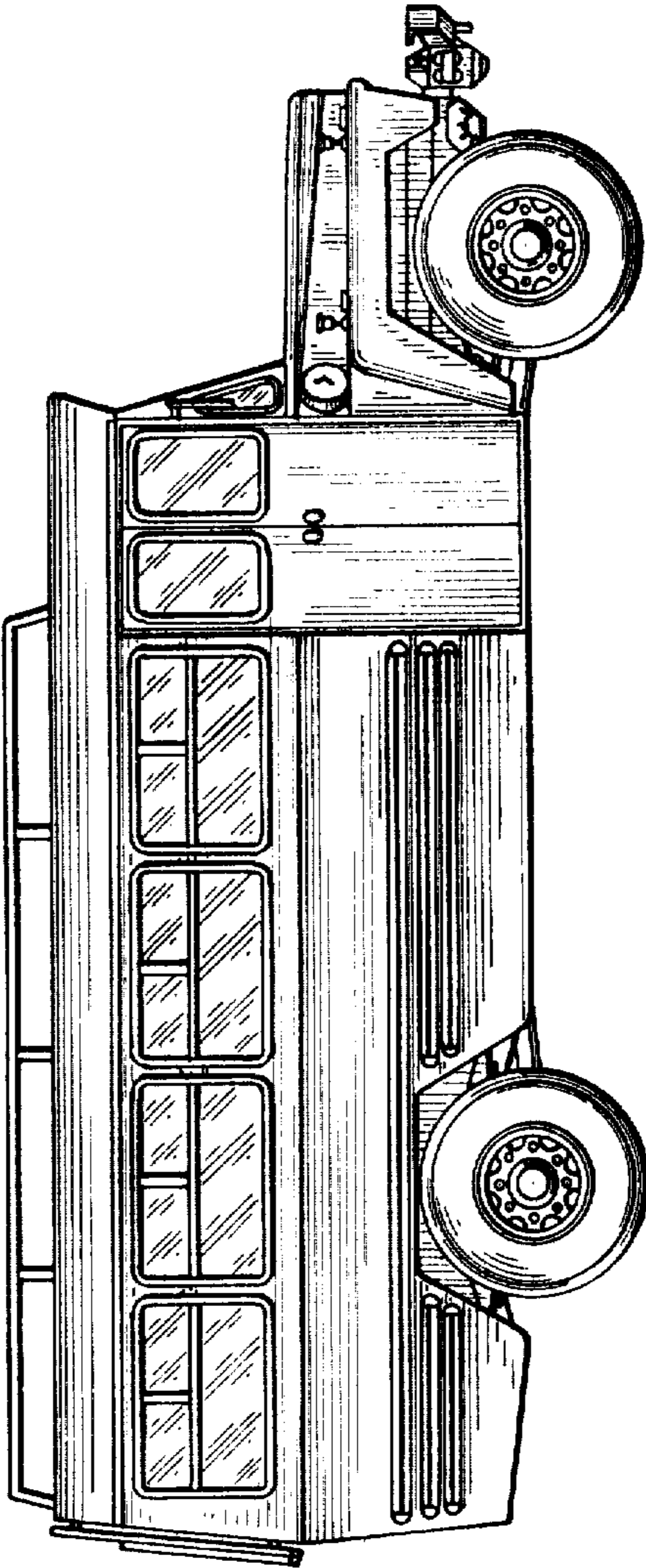

Fig. 6

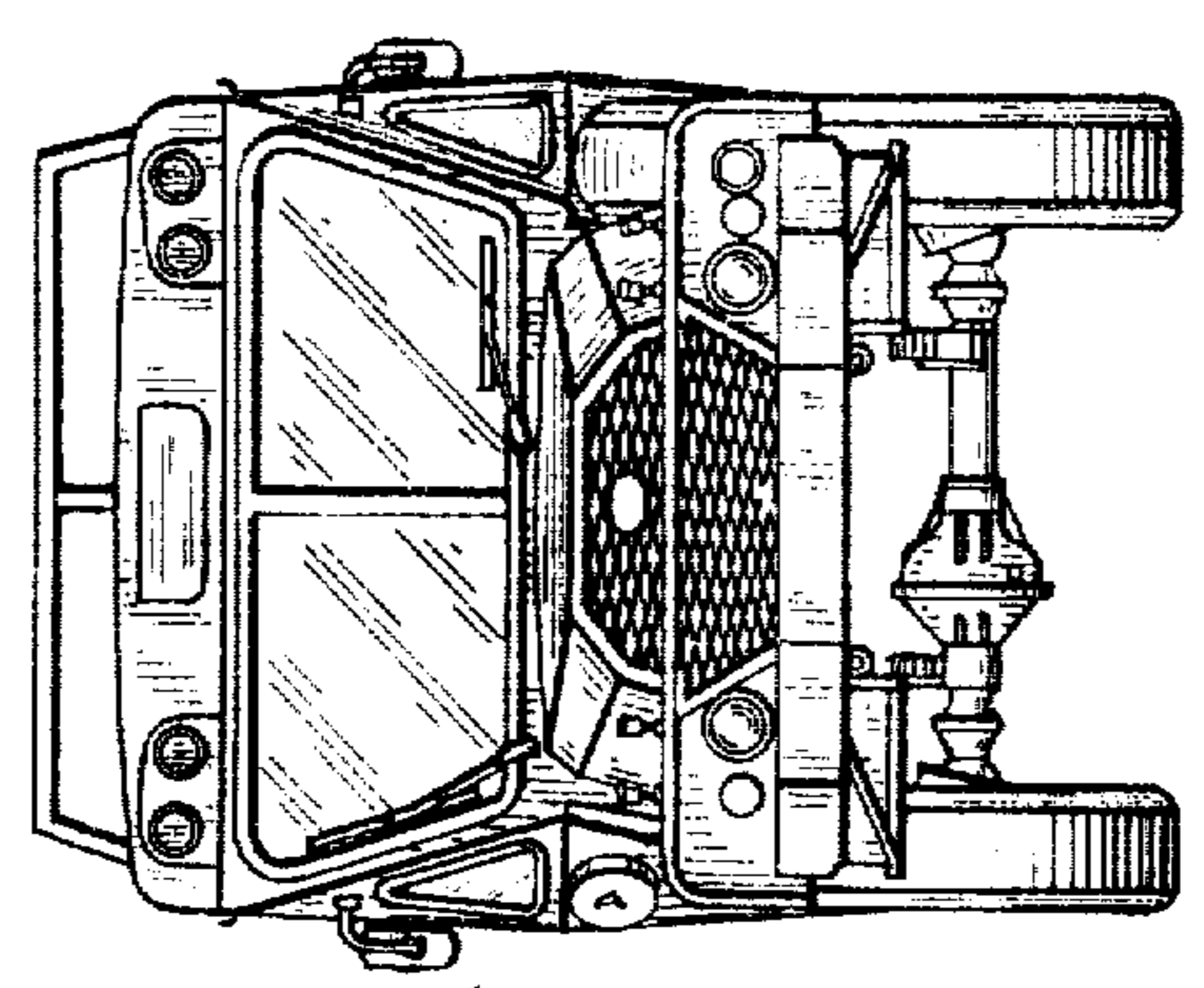

Fig. 5

