

[54] **AIR CARGO LOADING VEHICLE**

[75] **Inventor:** Wouter Verschoor, Elizabeth South, Australia

[73] **Assignee:** Static General Engineering Co. Pty. Ltd., Elizabeth South, Australia

[\*\*] **Term:** 14 Years

[21] **Appl. No.:** 94,862

[22] **Filed:** Nov. 15, 1979

[51] **Int. Cl.** ..... D12-05

[52] **U.S. Cl.** ..... D34/34; D12/1

[58] **Field of Search** ..... D12/14, 1; 414/495, 414/529; D34/34

[56] **References Cited**  
U.S. PATENT DOCUMENTS  
4,077,532 3/1978 Bryan ..... 414/495

*Primary Examiner*—James M. Gandy  
*Attorney, Agent, or Firm*—Brown & Martin

[57] **CLAIM**  
The ornamental design for an air cargo loading vehicle, substantially as shown and described.

**DESCRIPTION**

FIG. 1 is a perspective view of an air cargo loading vehicle, showing my new design;  
FIG. 2 is a top plan view thereof;  
FIG. 3 is a left side elevational view thereof;  
FIG. 4 is a front elevational view thereof with the roller bed in lowered condition;  
FIG. 5 is a rear elevational view thereof with the driver's cab in retracted position; and  
FIG. 6 is a right side elevational view thereof.

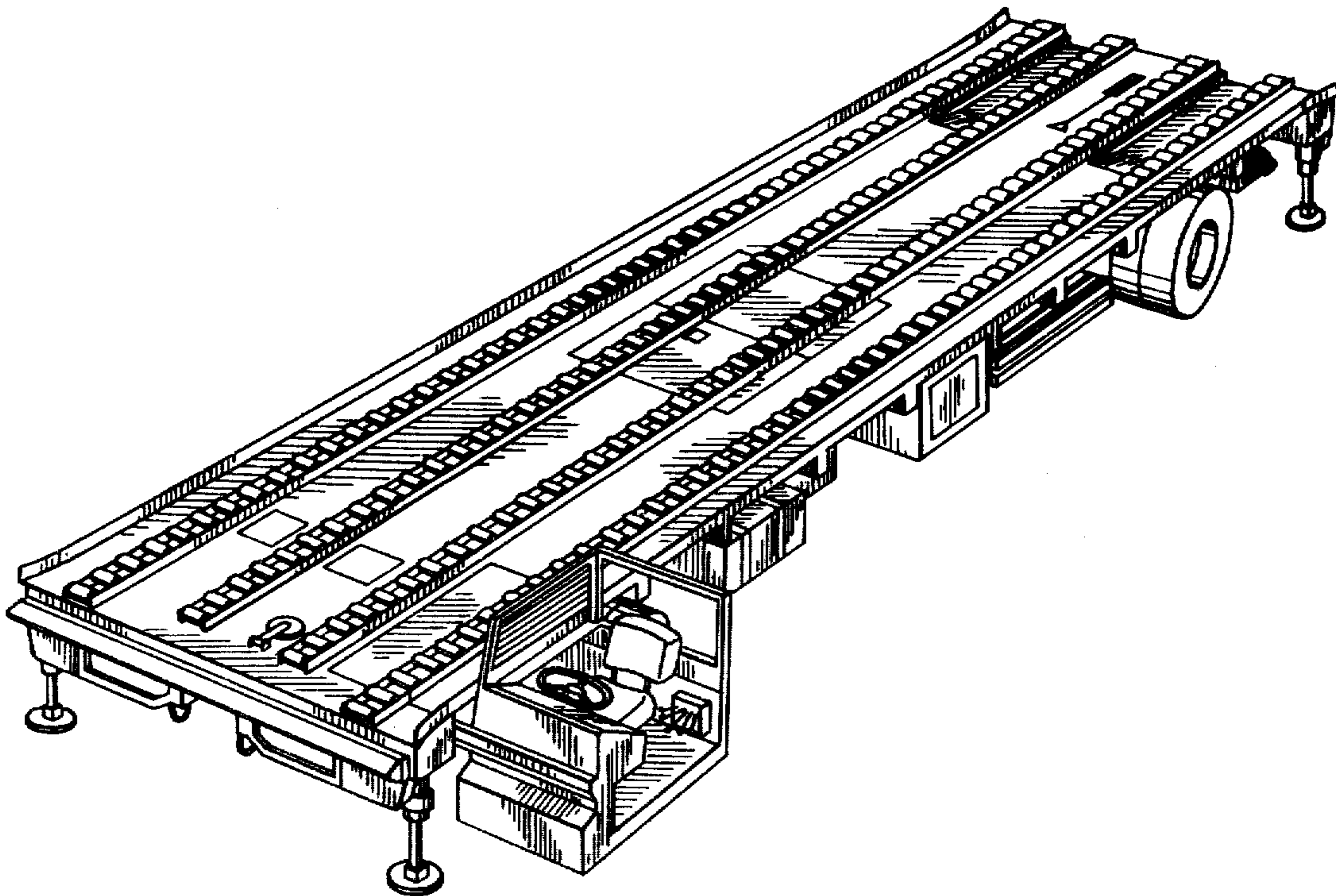

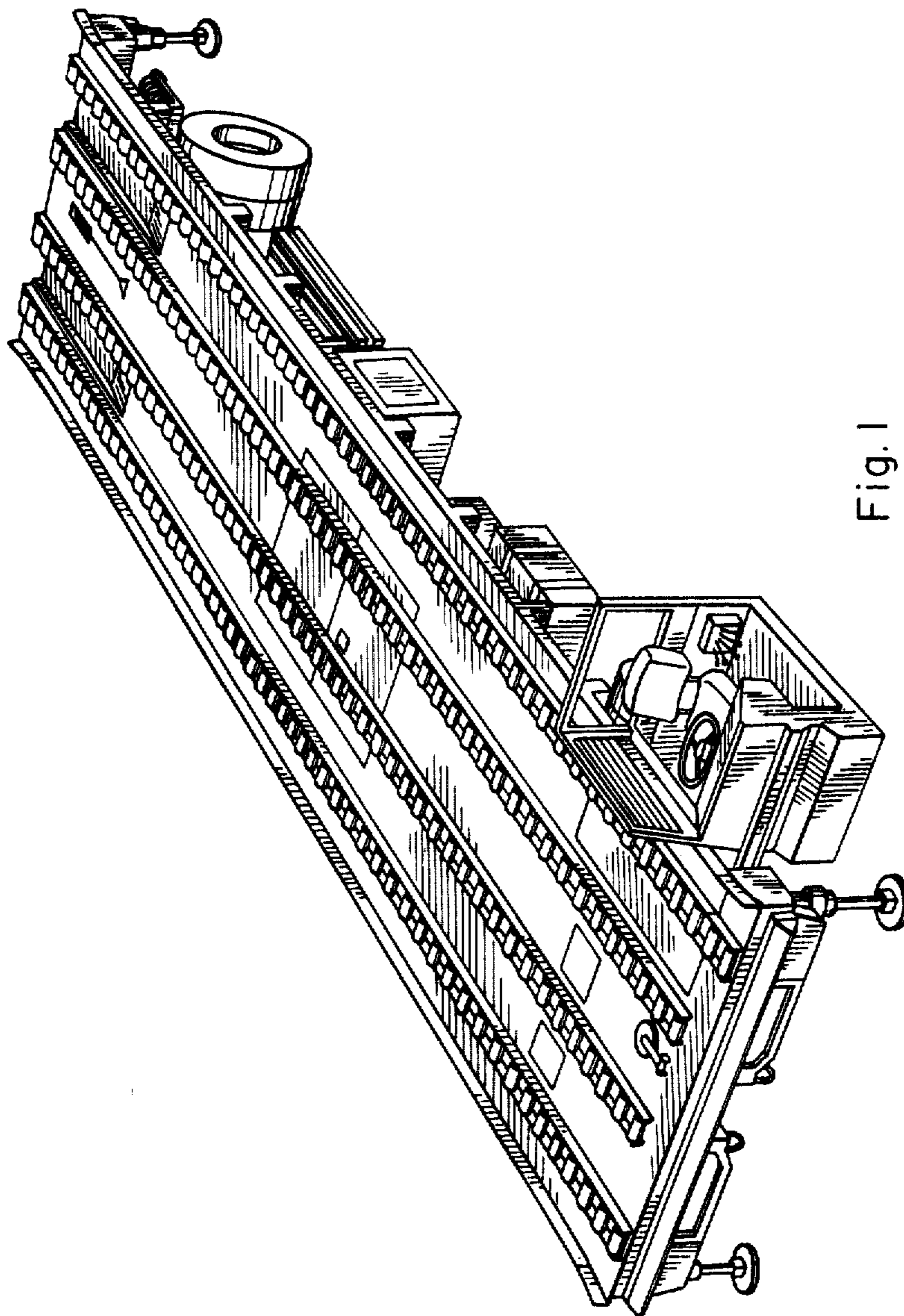

Fig. 1

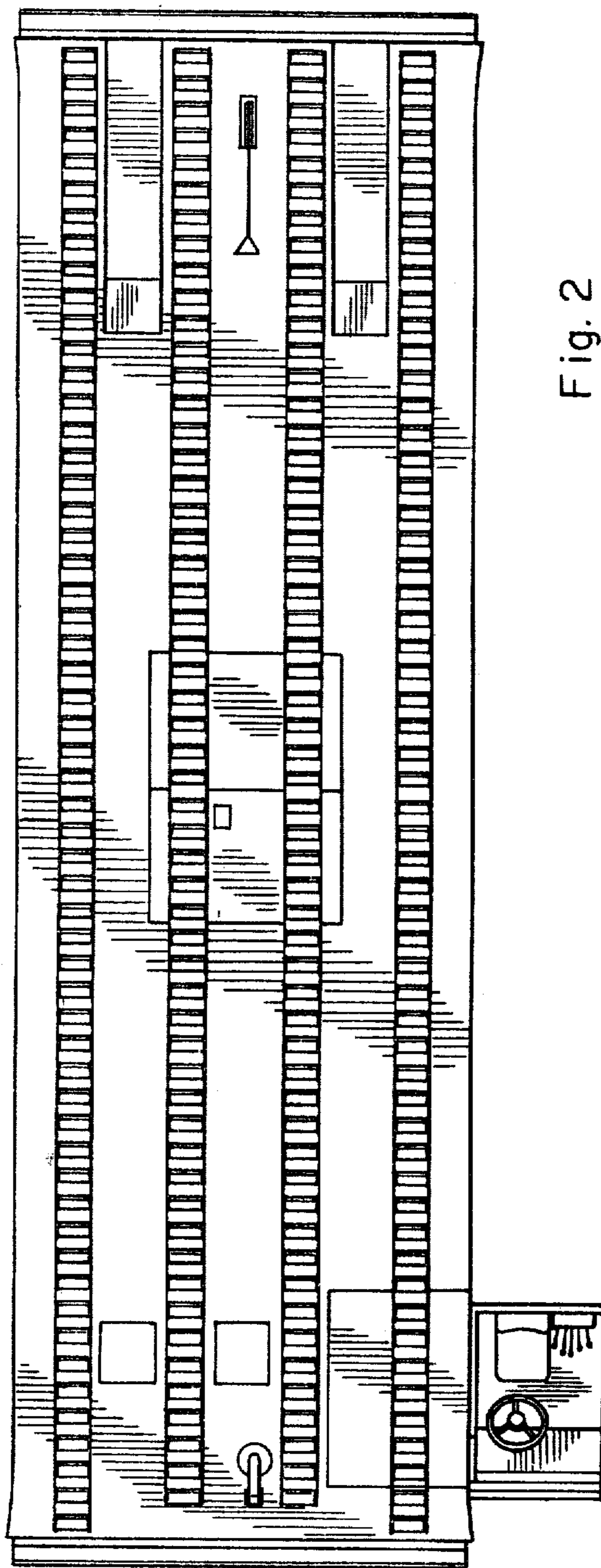

Fig. 2



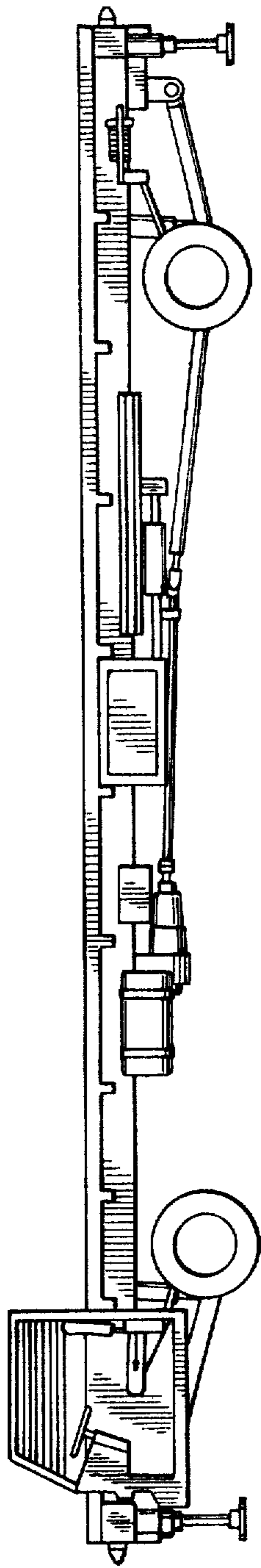

Fig. 3

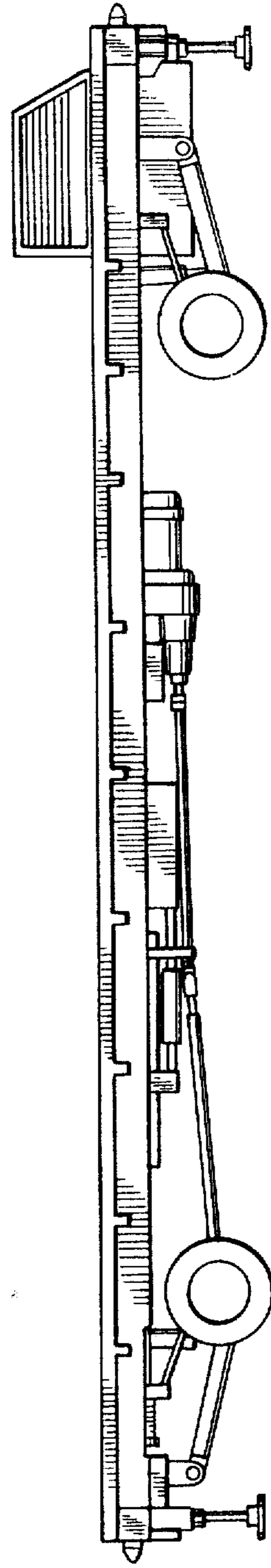

Fig. 6

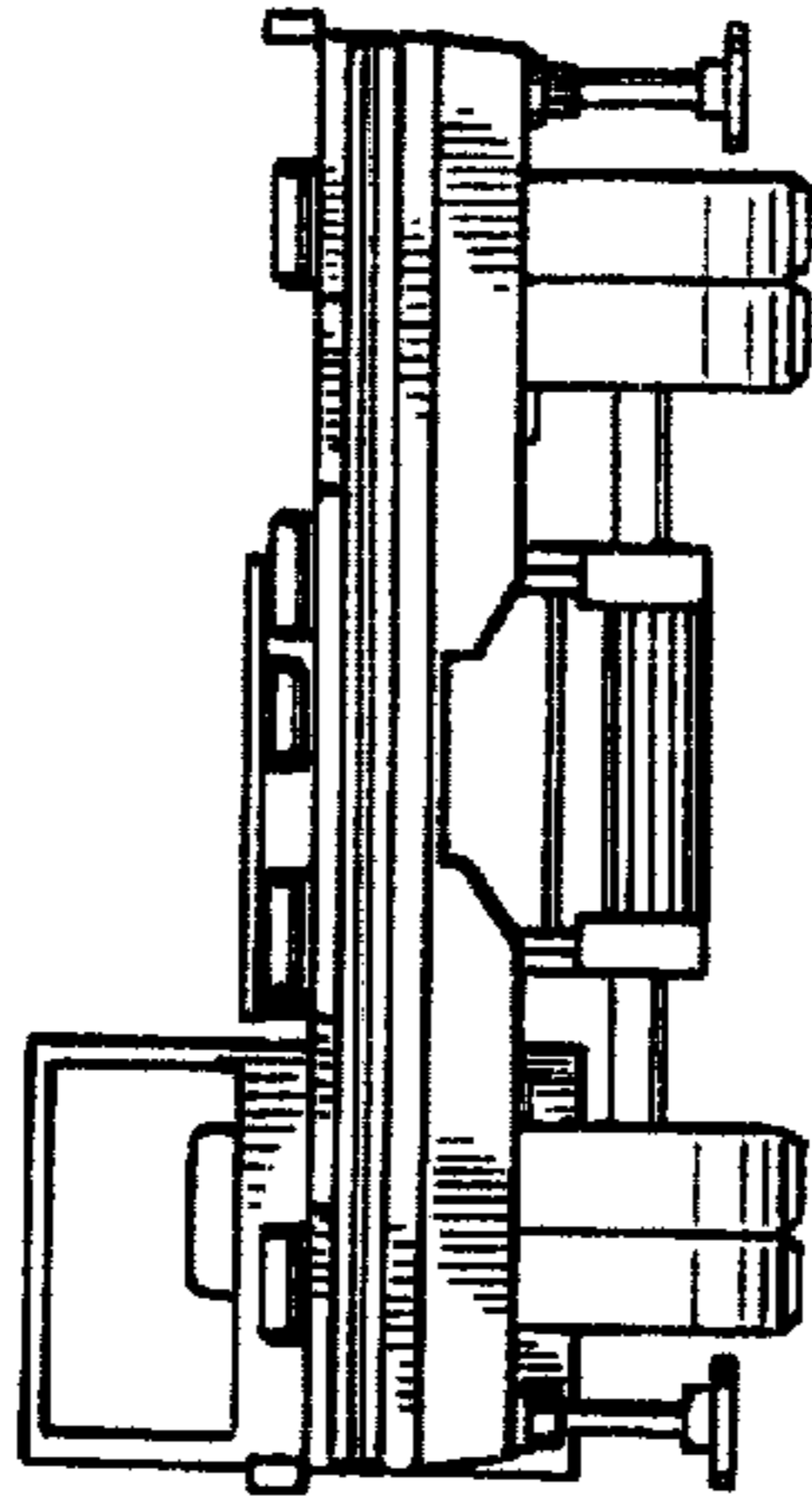

Fig. 5

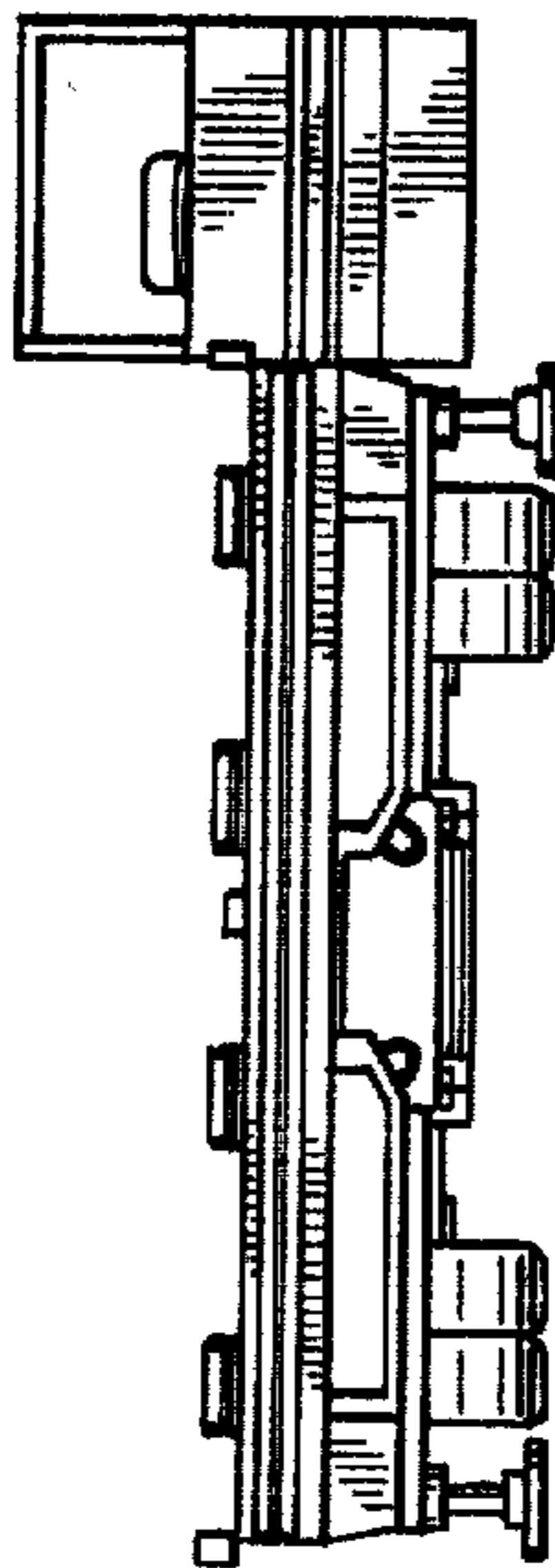

Fig. 4