

[54] **VEHICLE WHEEL**

[75] **Inventor:** **Raymond J. Hedlund**, Concord, Calif.
[73] **Assignee:** **Kelsey-Hayes Co.**, Romulus, Mich.
[**] **Term:** **14 Years**
[21] **Appl. No.:** **305,746**
[22] **Filed:** **Sep. 25, 1981**

[51] **Int. Cl.** **D12-16**
[52] **U.S. Cl.** **D12/211**
[58] **Field of Search** **D12/209, 211; 301/63 R, 301/63 PW, 64 R, 64 SD, 65**

[56] **References Cited**
U.S. PATENT DOCUMENTS

D. 261,879 11/1981 Envall et al. D12/211
D. 264,836 6/1982 Main et al. D12/211

OTHER PUBLICATIONS

Modern Tire Dealer, 2/77, p. 66, International Slot--Mag Wheel, top center of page.

Primary Examiner—James M. Gandy
Attorney, Agent, or Firm—Ralph J. Skinkiss

[57] **CLAIM**

The ornamental design for a vehicle wheel, substantially as shown and described.

DESCRIPTION

FIG. 1 is a right front perspective view of a vehicle wheel showing my new design.
FIG. 2 is a front elevational view thereof.
FIG. 3 is an enlarged sectional view taken along line 3—3 in FIG. 2.
FIG. 4 is an enlarged sectional view taken along line 4—4 in FIG. 2.
FIG. 5 is an enlarged sectional view taken along line 5—5 in FIG. 2.
FIG. 6 is a left front perspective view of a vehicle wheel showing a second embodiment of my new design.
FIG. 7 is an enlarged sectional view taken along line 7—7 in FIG. 6.

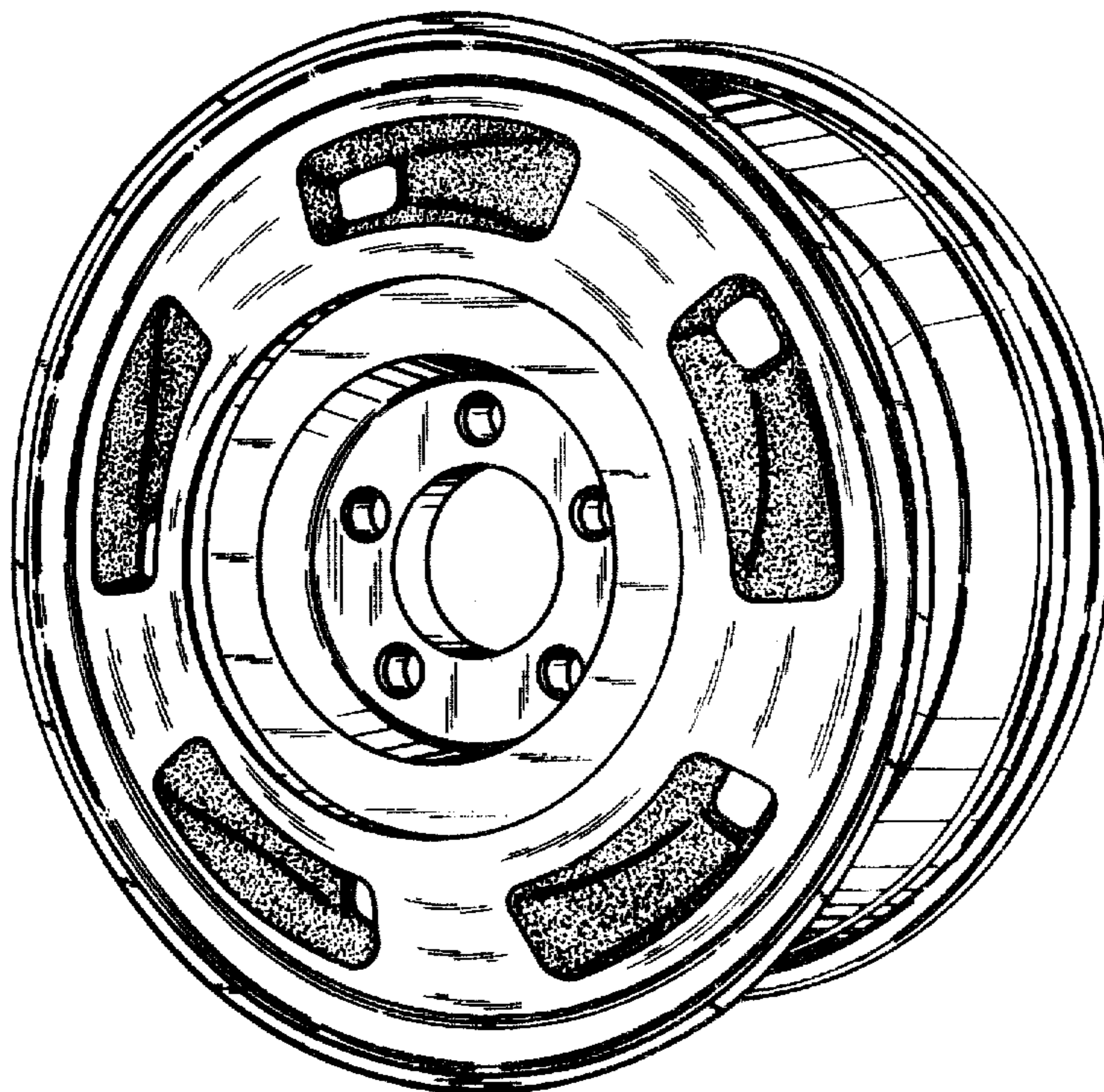

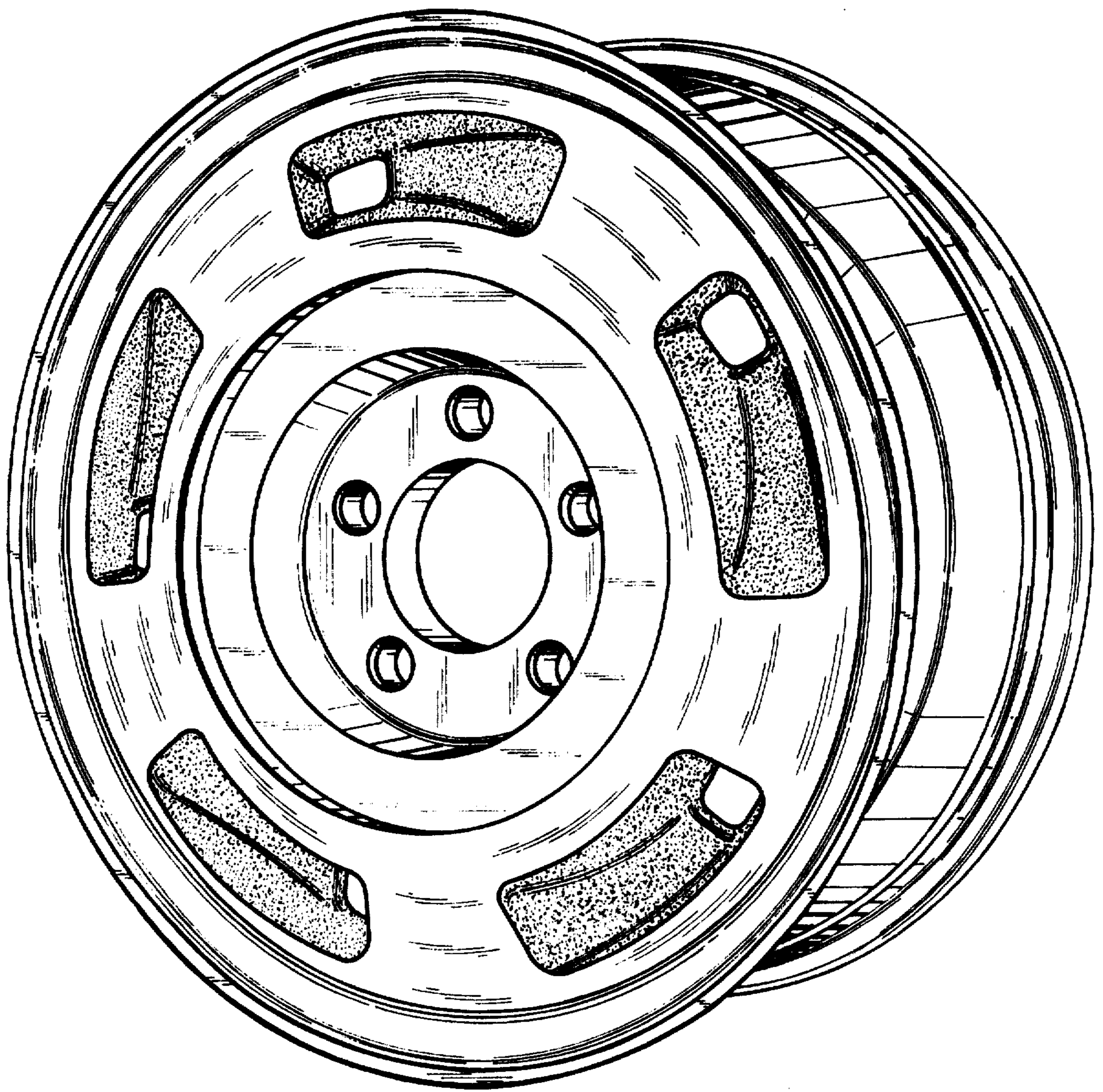

—FIG. 1

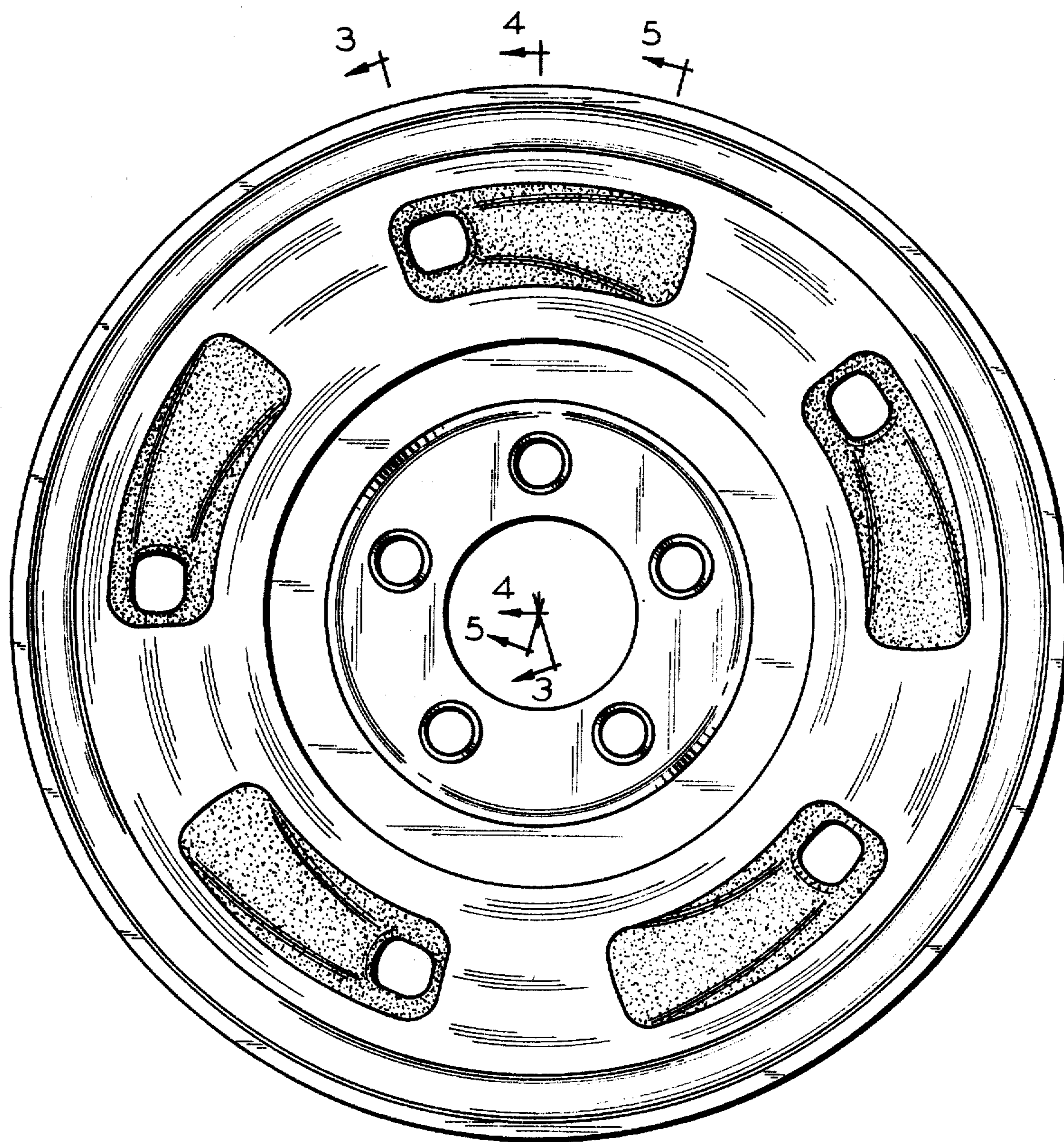

—FIG. 2

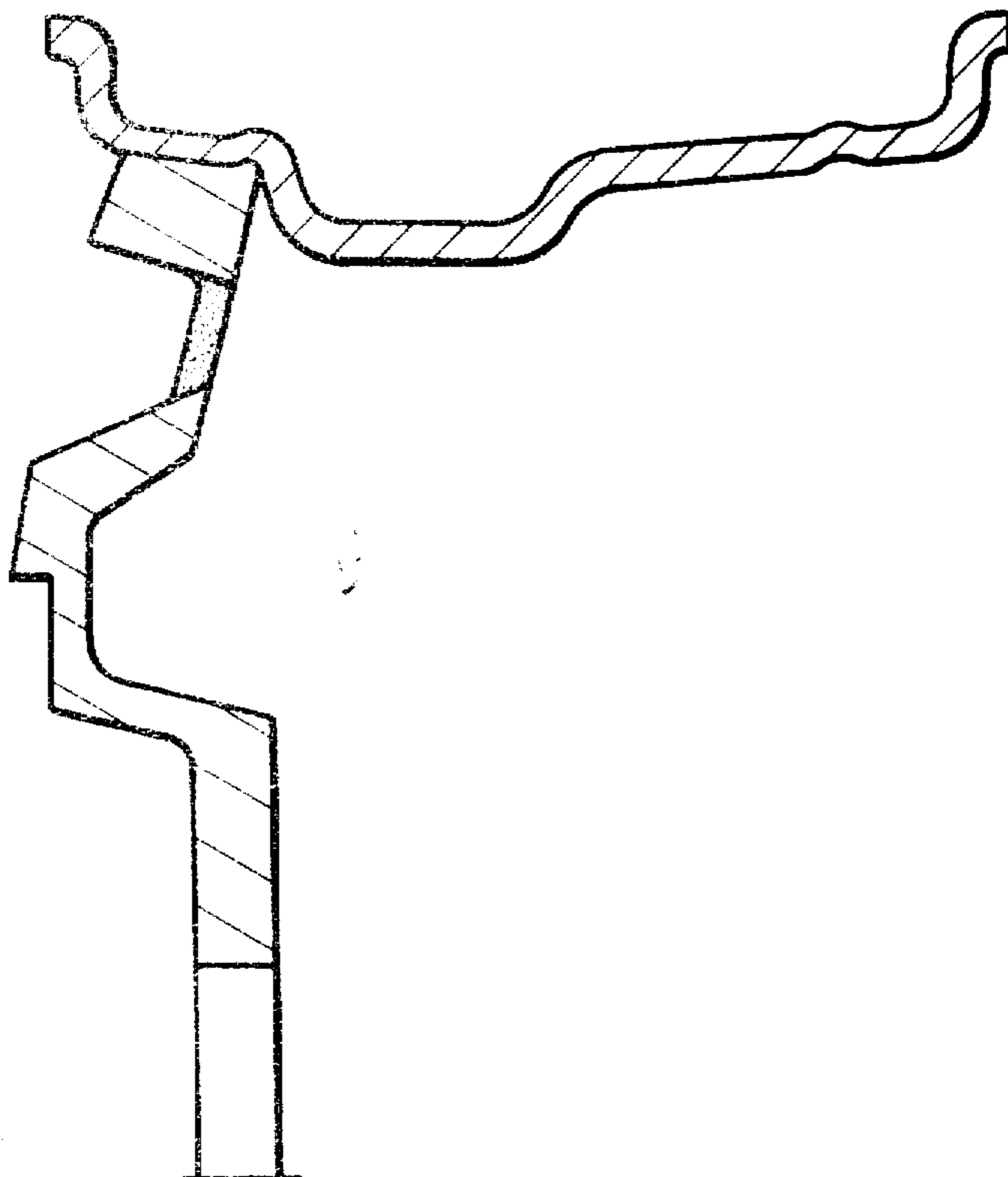

— FIG. 3

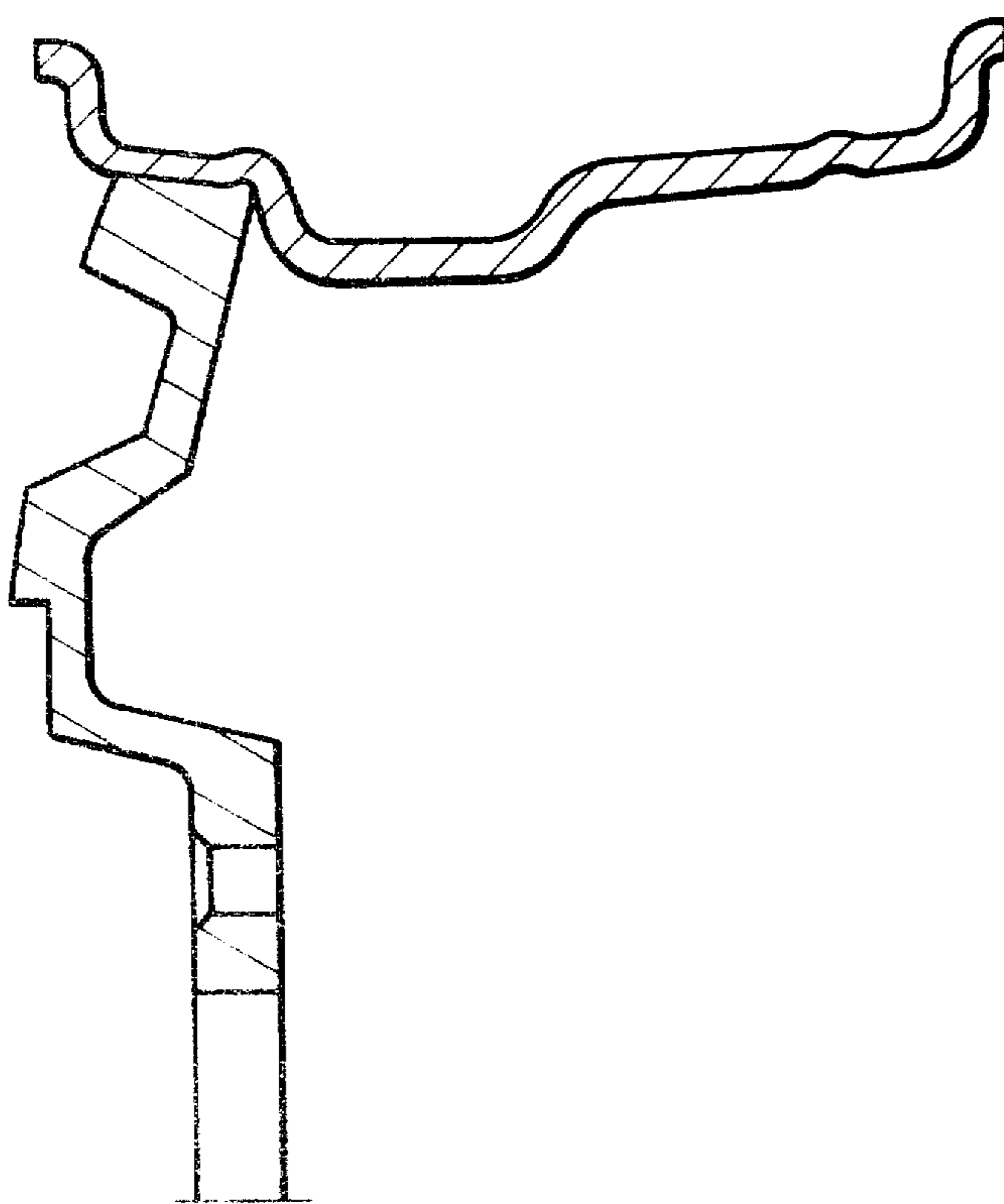

— FIG. 4

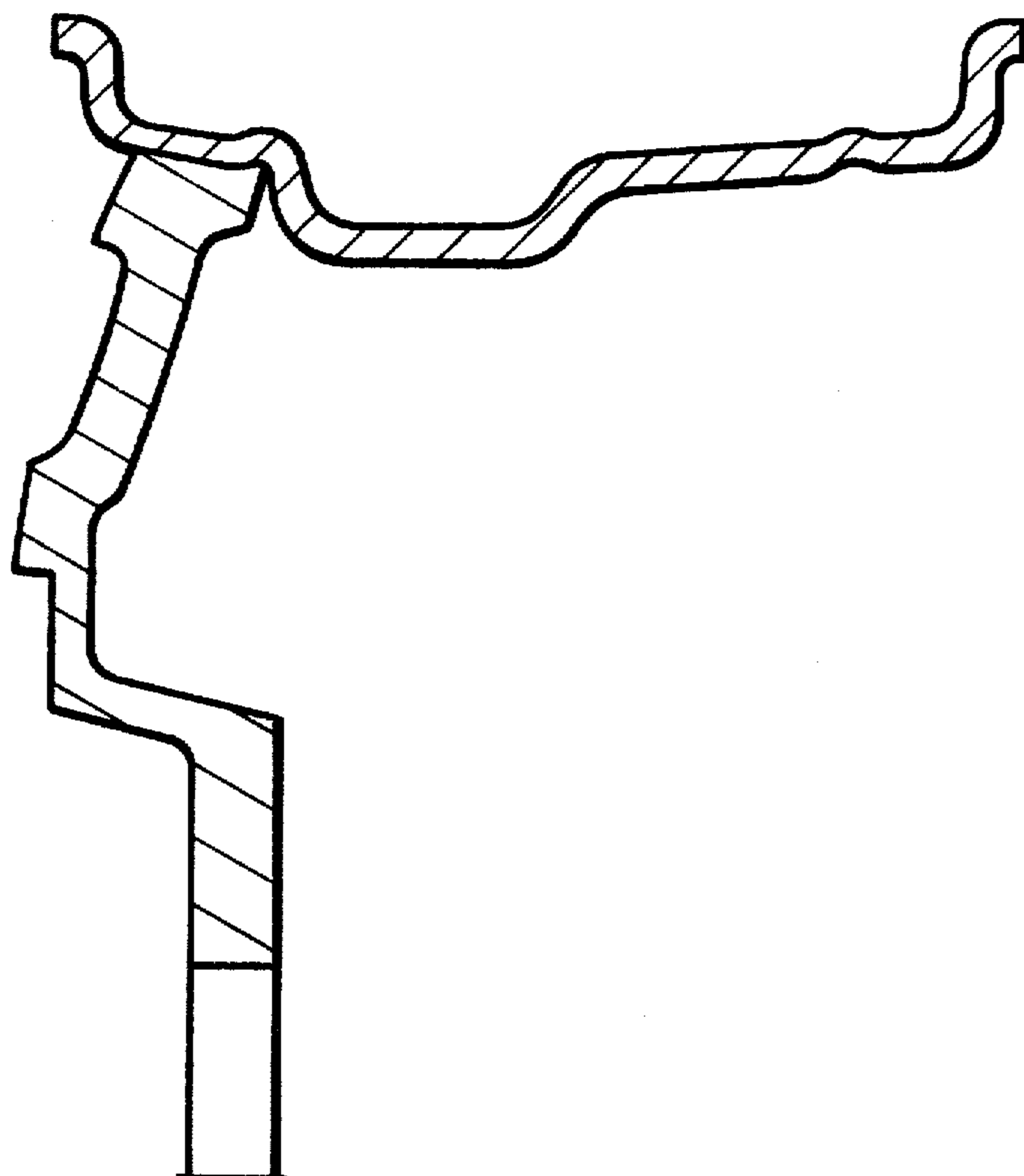

— FIG. 5

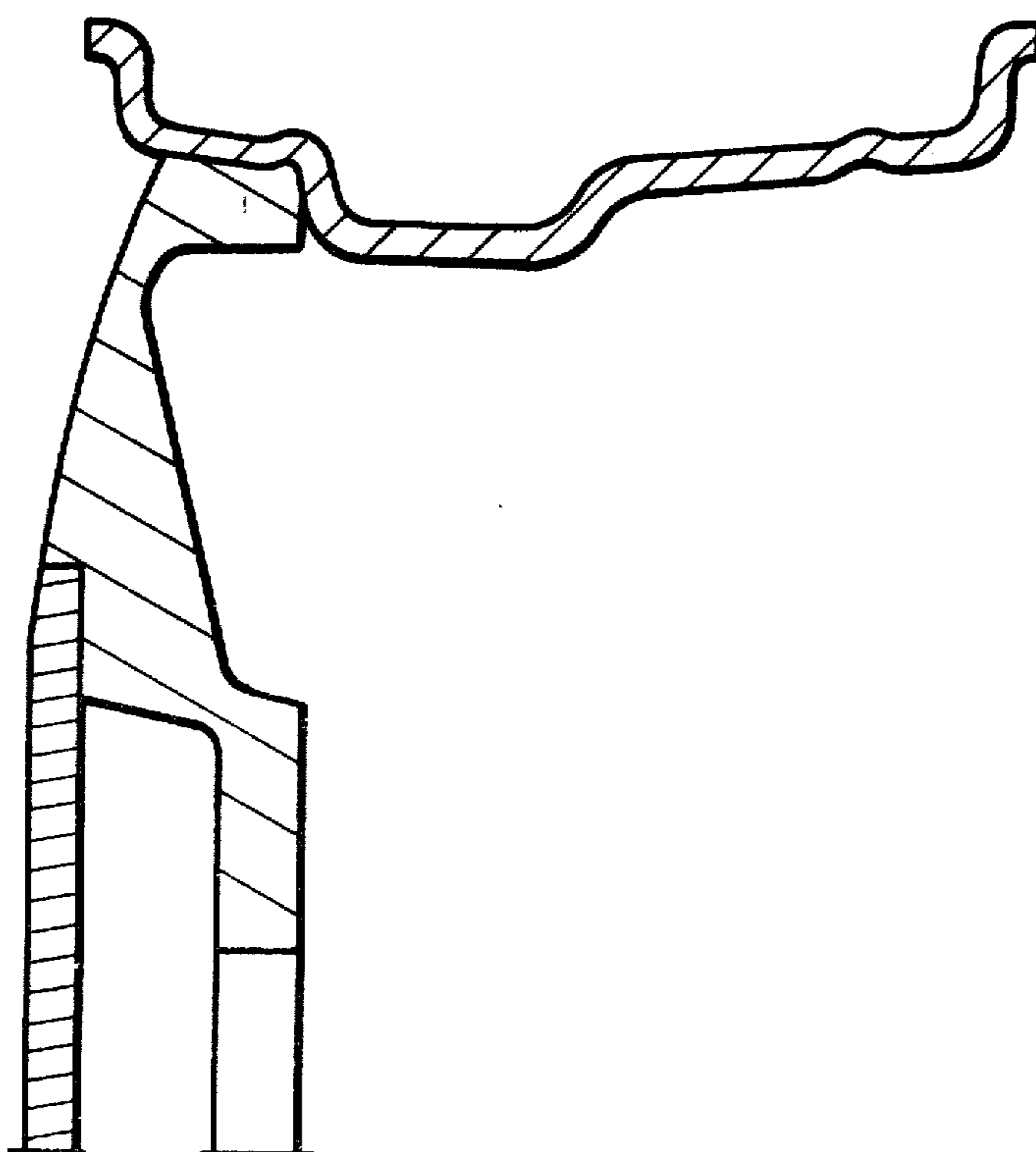

— FIG. 7

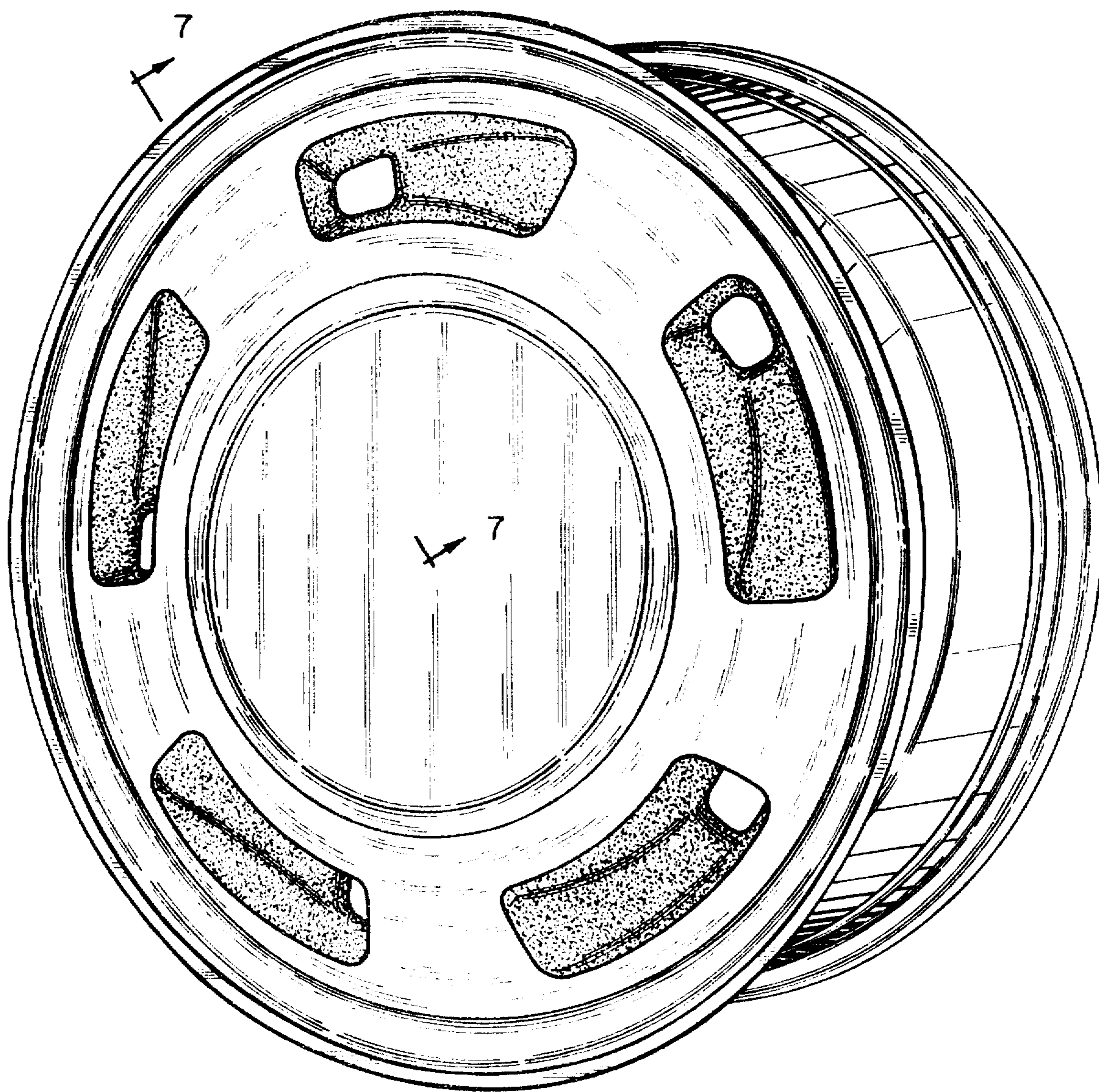

—FIG. 6