

[54] **AIRCRAFT DOCKING DISPLAY**

[76] **Inventor:** Nils-Eric Anderberg, Västratorp 589,
S-231 00 Trelleborg, Sweden

[**] **Term:** 14 Years

[21] **Appl. No.:** 288,682

[22] **Filed:** Jul. 31, 1981

[30] **Foreign Application Priority Data**

Feb. 5, 1981 [SE] Sweden 81-0259

[51] **Int. Cl.** D10-06

[52] **U.S. Cl.** D10/114; D10/109;
D10/67

[58] **Field of Search** D10/114, 109, 67, 74,
D10/103; 244/114 R; 340/26, 31, 51; 73/178 T;
116/29, 50, 124

[56]

References Cited

U.S. PATENT DOCUMENTS

D. 222,386	10/1971	Kirschner	D10/67
3,307,191	2/1967	Crane	73/178 T
3,690,599	9/1972	Hager	244/114 R
3,729,267	4/1973	Snead	244/114 R X
3,873,210	3/1975	Konopka	340/26 X
4,184,655	1/1980	Anderberg	116/29 X
4,249,159	2/1981	Stasko	244/114 R X

Primary Examiner—Nelson C. Holtje
Attorney, Agent, or Firm—Brumbaugh, Graves,
Donohue & Raymond

[57]

CLAIM

The ornamental design for an aircraft docking display,
as shown.

DESCRIPTION

FIG. 1 is a right front perspective view of an aircraft
docking display showing my new design;
FIG. 2 is a top plan view thereof;
FIG. 3 is a right side elevational view thereof;
FIG. 4 is a bottom plan view thereof;
FIG. 5 is a rear elevational view thereof.

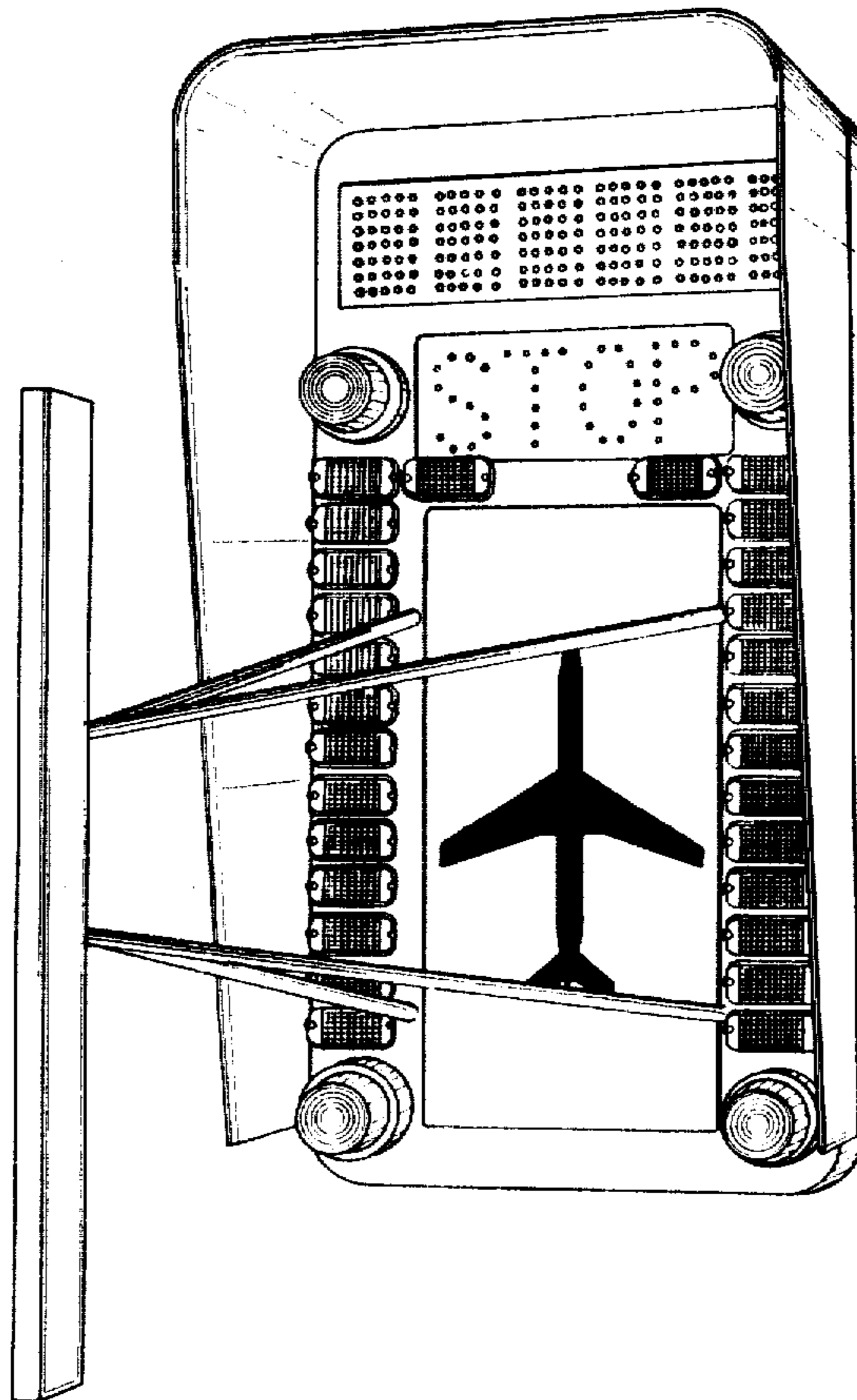

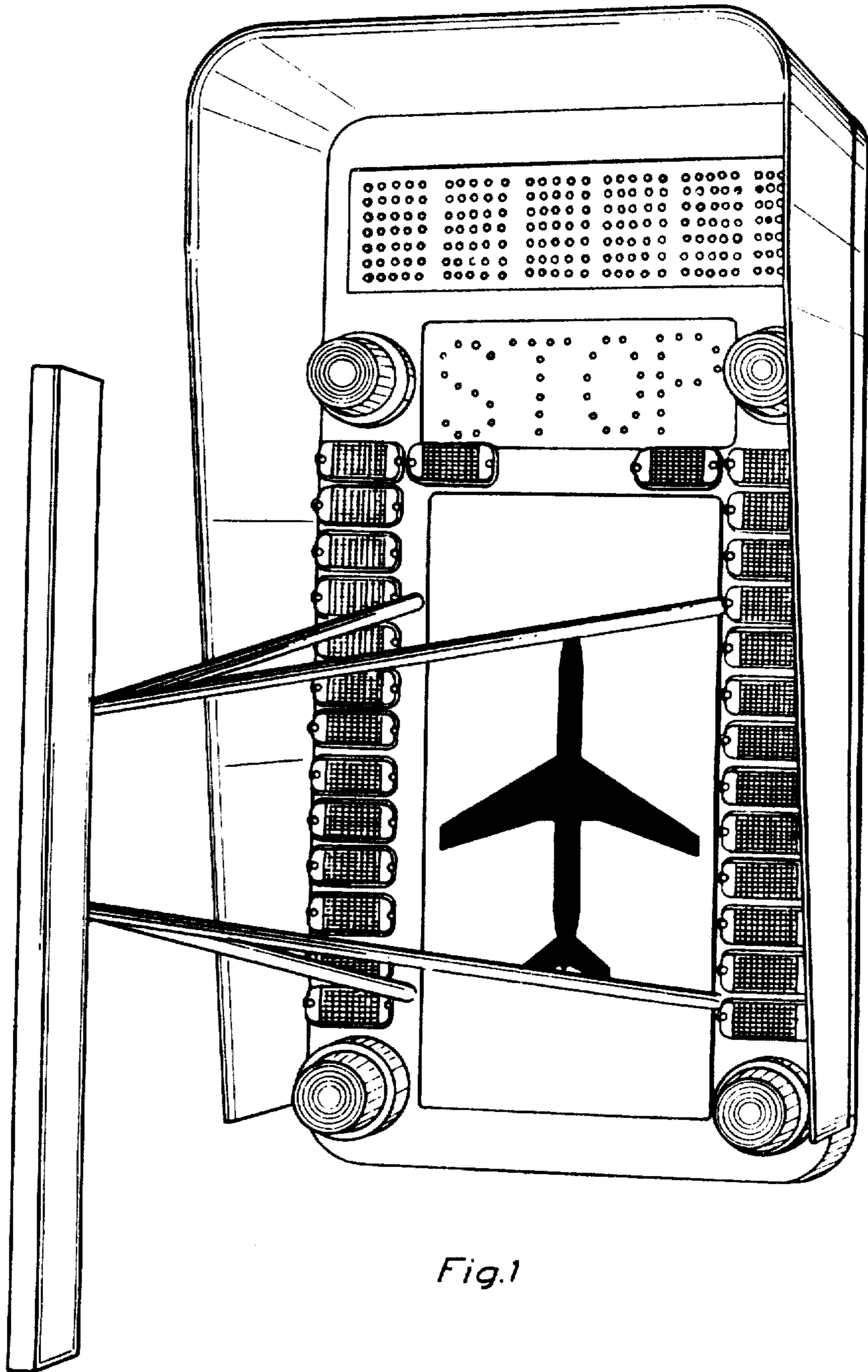

Fig.1

Fig. 2

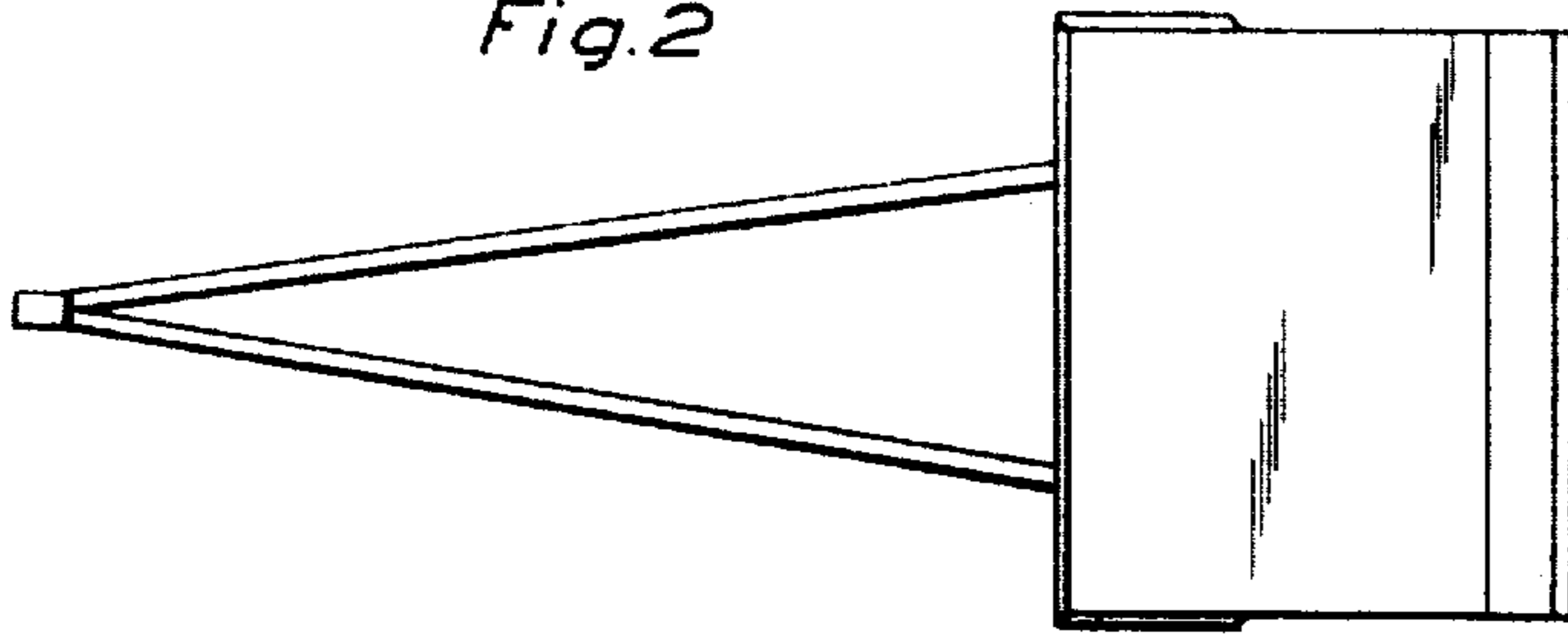

Fig. 3

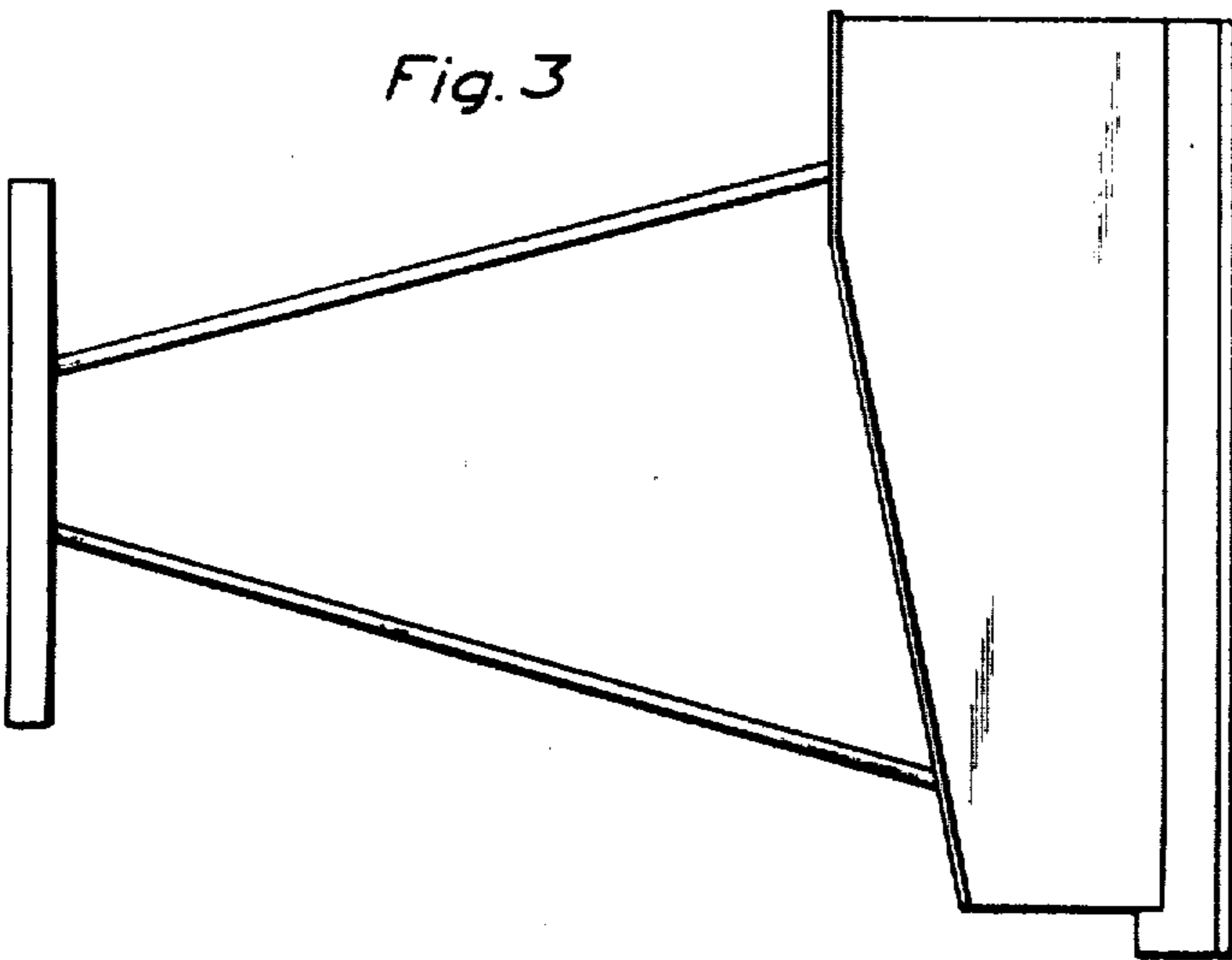

Fig. 5

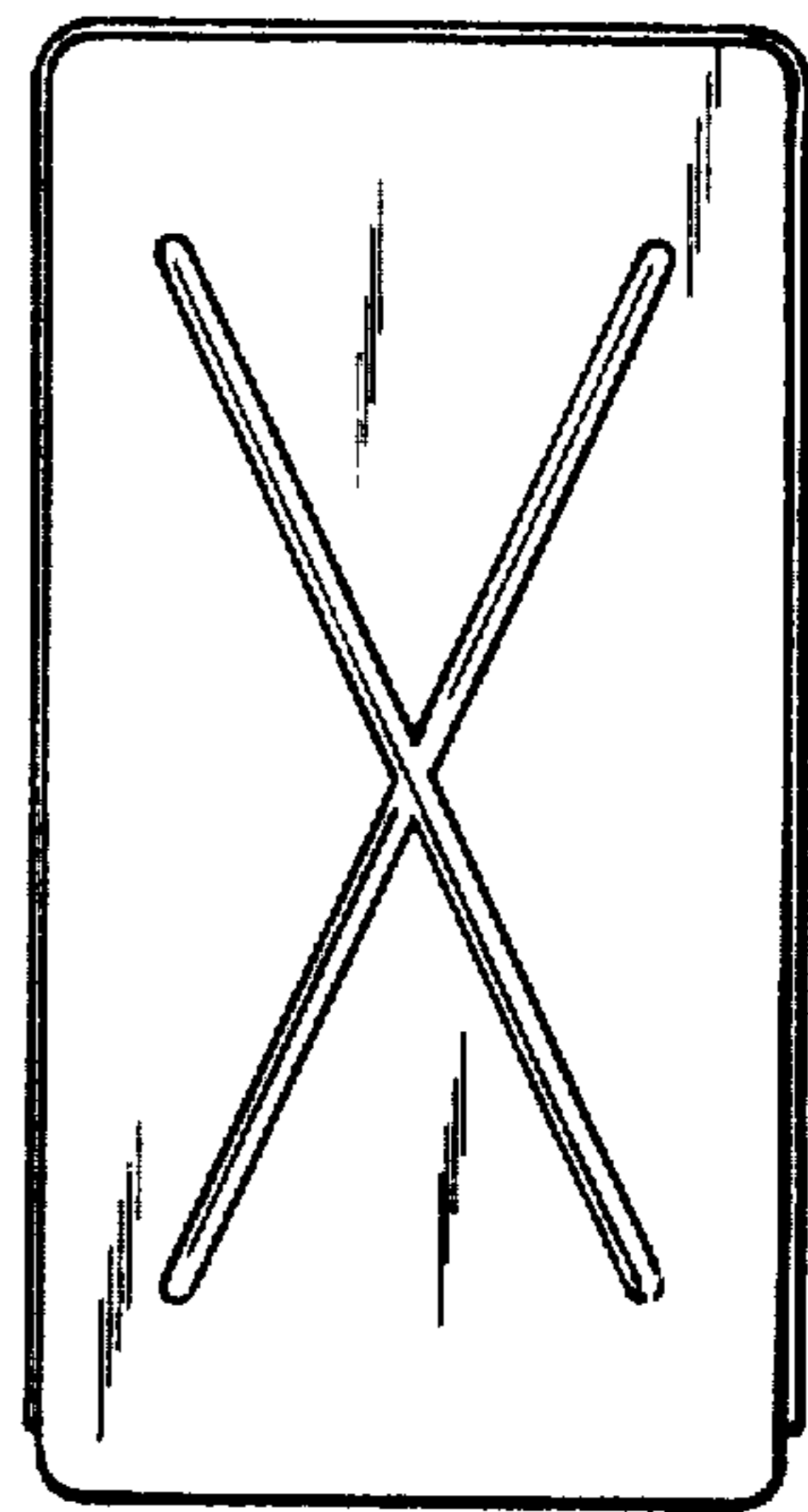

Fig. 4

