

[54] AIRCRAFT CONSOLE

[76] Inventor: David L. Benson, 7474 Carmel La., Grand Ledge, Mich. 48837

[**] Term: 14 Years

[21] Appl. No.: 328,917

[22] Filed: Feb. 9, 1981

[51] Int. Cl. D12-16

[52] U.S. Cl. D3/40; D12/345

[58] Field of Search D3/40; 244/1 R, 129.1; 108/44, 47, 48; 296/37.1, 37.8, 37.13, 37.14, 37.15, 37.16; 224/273, 42.11, 42.42; D12/345

[56] References Cited

U.S. PATENT DOCUMENTS

- D. 202,384 9/1965 Wilson D3/40 X
- D. 207,916 6/1967 White D3/40
- D. 232,871 9/1974 George et al. D3/40
- D. 237,166 10/1975 Jensen D3/40 X
- D. 248,056 5/1978 Nepper D3/40

Primary Examiner—Catherine E. Kemper
Attorney, Agent, or Firm—Miller, Morriss & Pappas

[57] CLAIM

The ornamental design for an aircraft console, as shown and described.

DESCRIPTION

FIG. 1 is a right perspective view of an aircraft console showing my new design.

FIG. 2 is a right perspective view of an aircraft console showing a modified form of my new design.

FIG. 3 is a front elevational view thereof.

FIG. 4 is a side elevational view thereof, the opposite side being a mirror image thereof.

FIG. 5 is a rear elevational view thereof.

FIG. 6 is a top plan view thereof shown on a reduced scale.

FIG. 7 is a bottom perspective view thereof.

FIG. 8 is a top view of the modified form of my new design shown in FIG. 2.

FIG. 9 is a right perspective view of an aircraft console showing another modified form of my new design.

FIG. 10 is a side elevational view of the modified form of my new design shown in FIG. 9, the opposite side being a mirror image thereof.

FIG. 11 is a rear elevational view of the modified form of my new design shown in FIG. 9.

FIG. 12 is a front elevational view of the modified form of my new design shown in FIG. 9.

FIG. 13 is a top view of the modified form of my new design shown in FIG. 9.

The broken line disclosure of an aircraft cabin in FIG. 6 is for illustrative purposes only and forms no part of the claimed design.

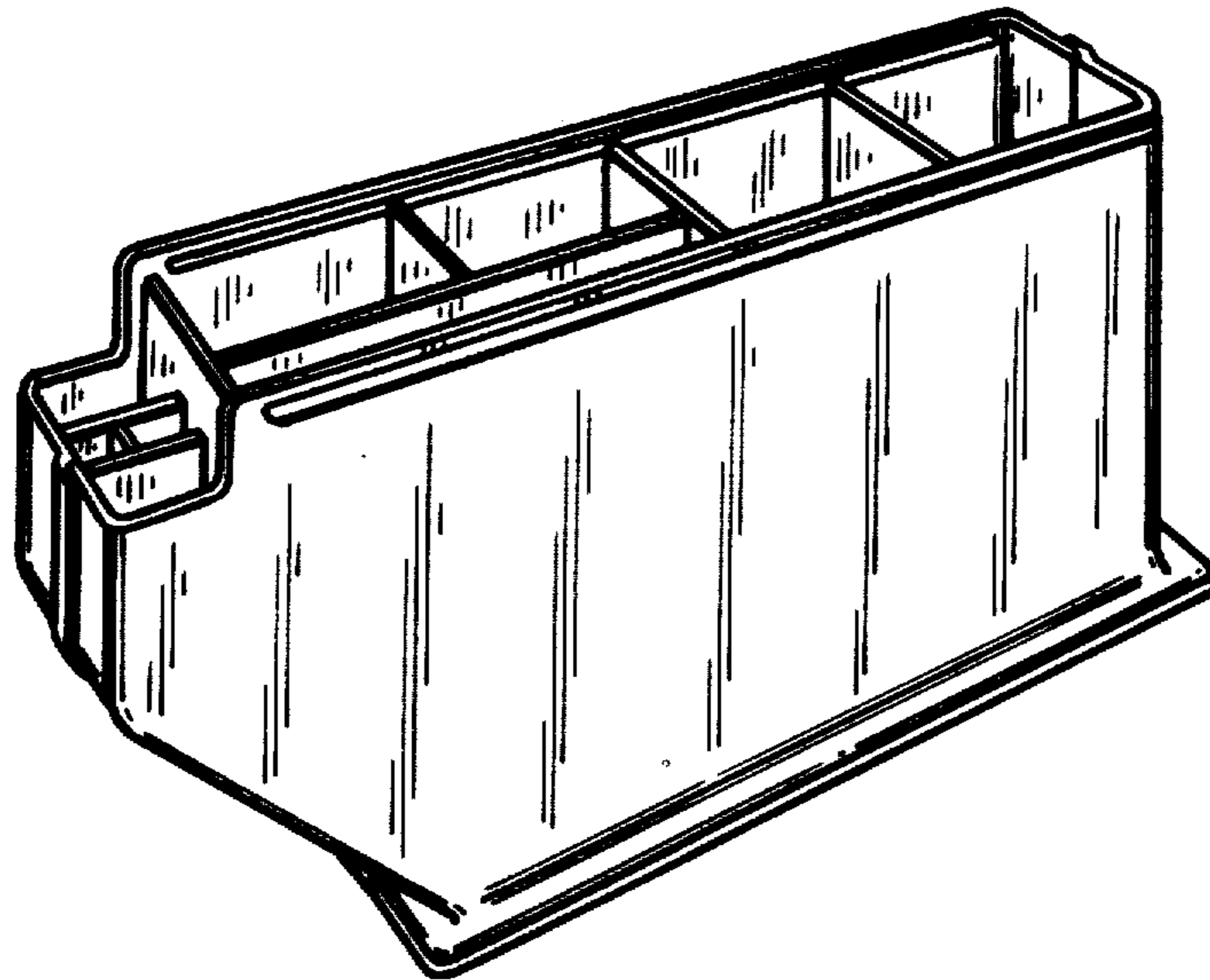

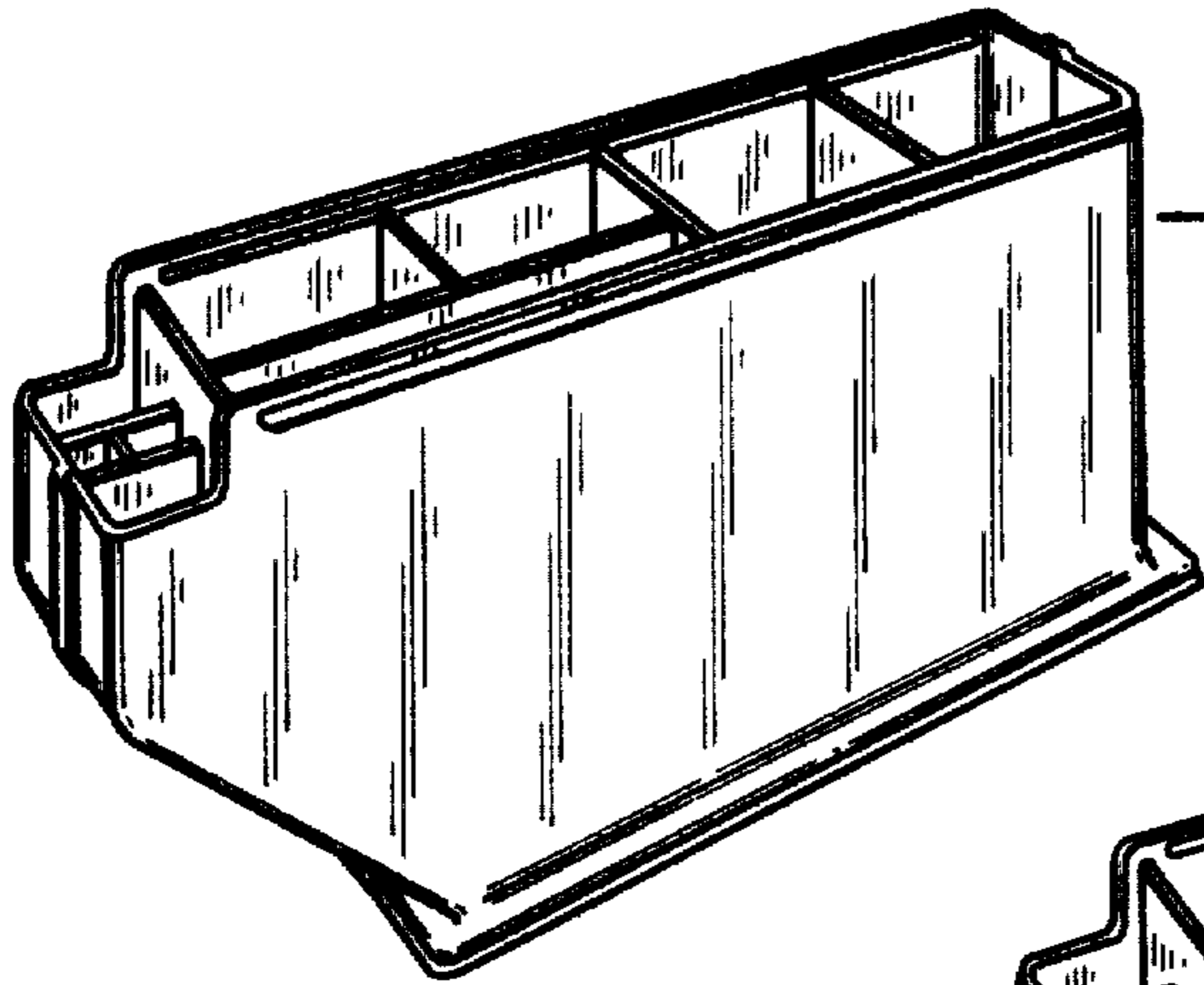

—FIG. 1

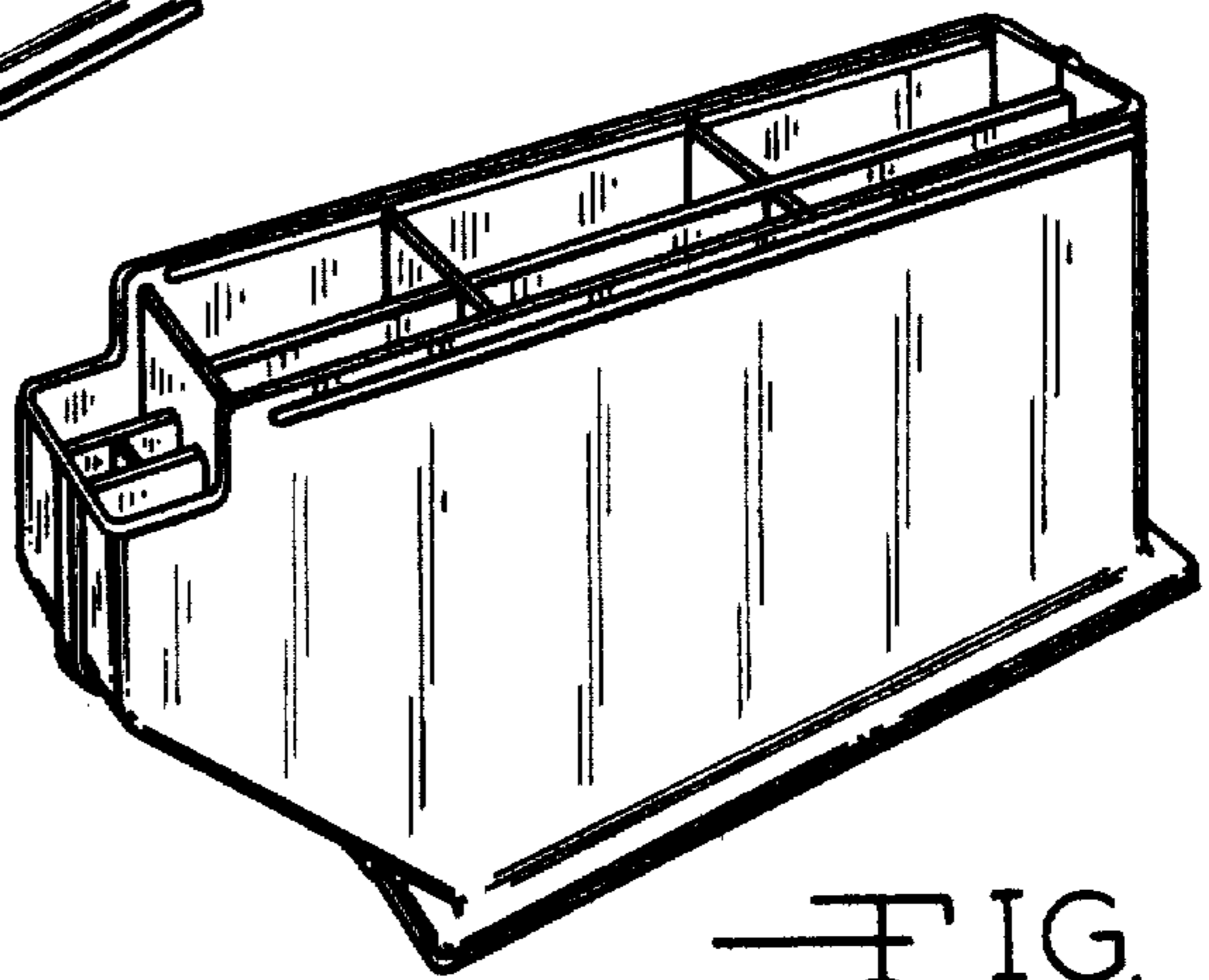

—FIG. 2

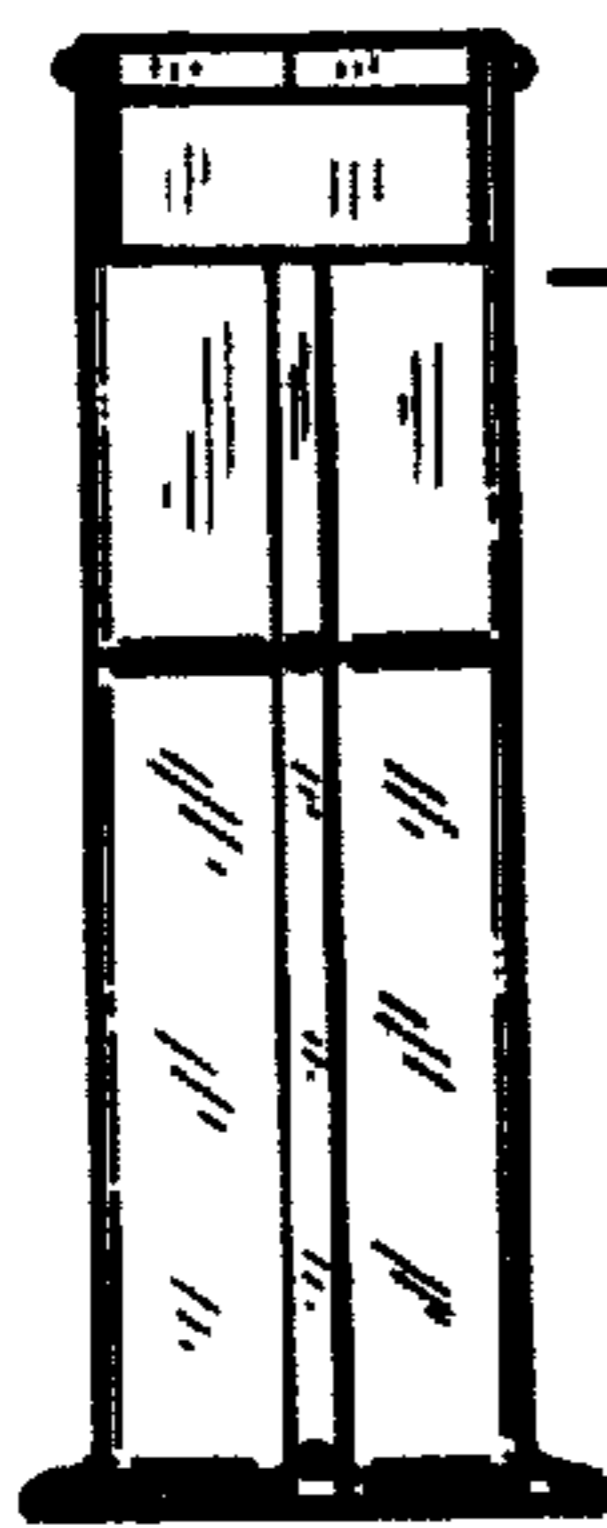

—FIG. 3

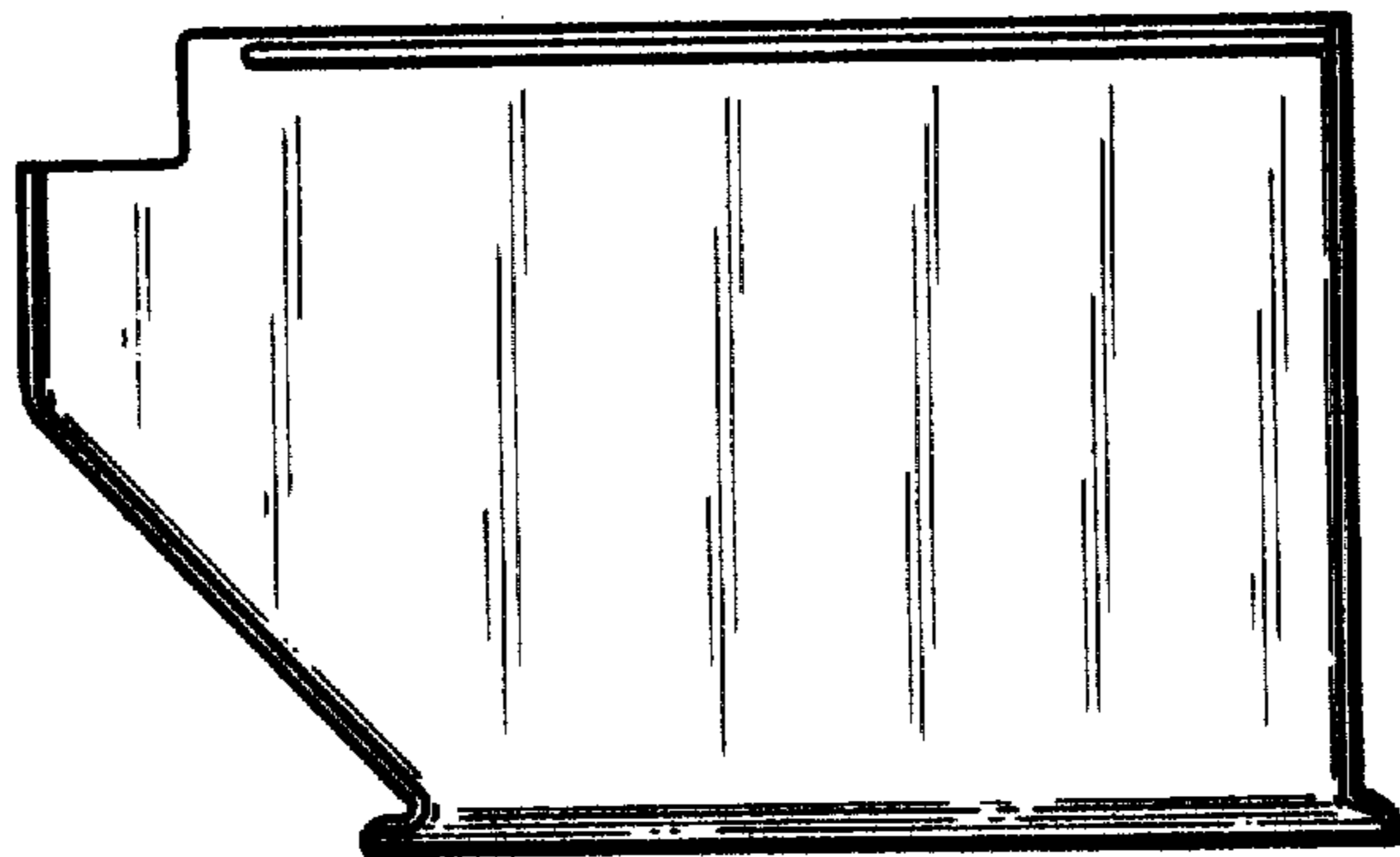

—FIG. 4

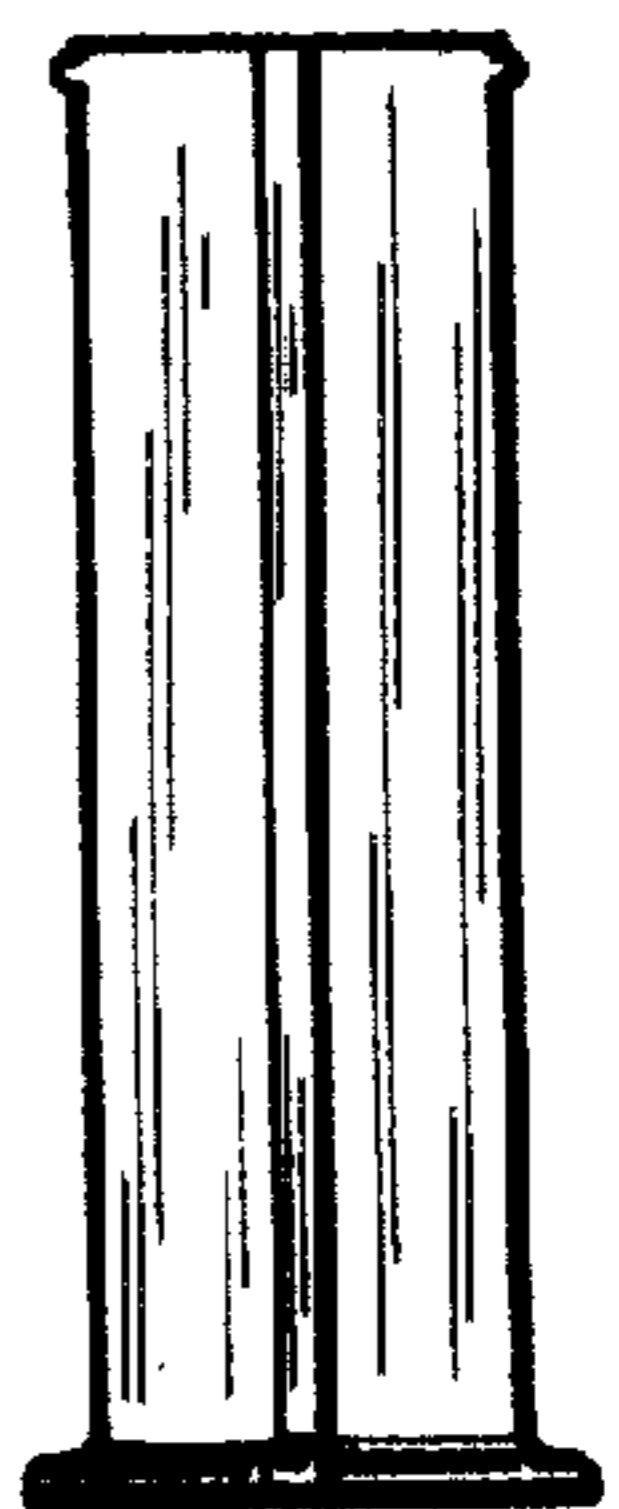

—FIG. 5

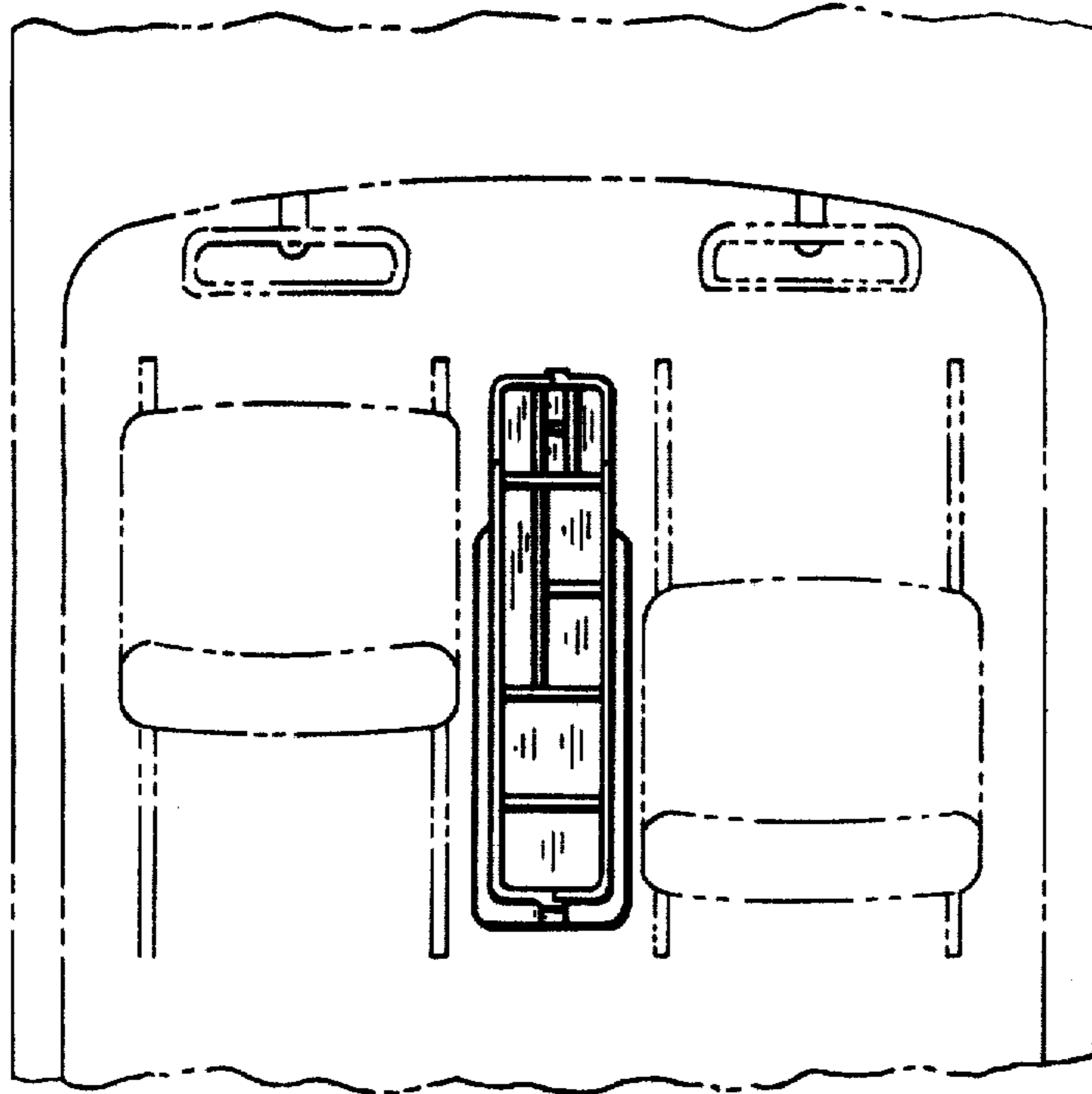

—FIG. 6

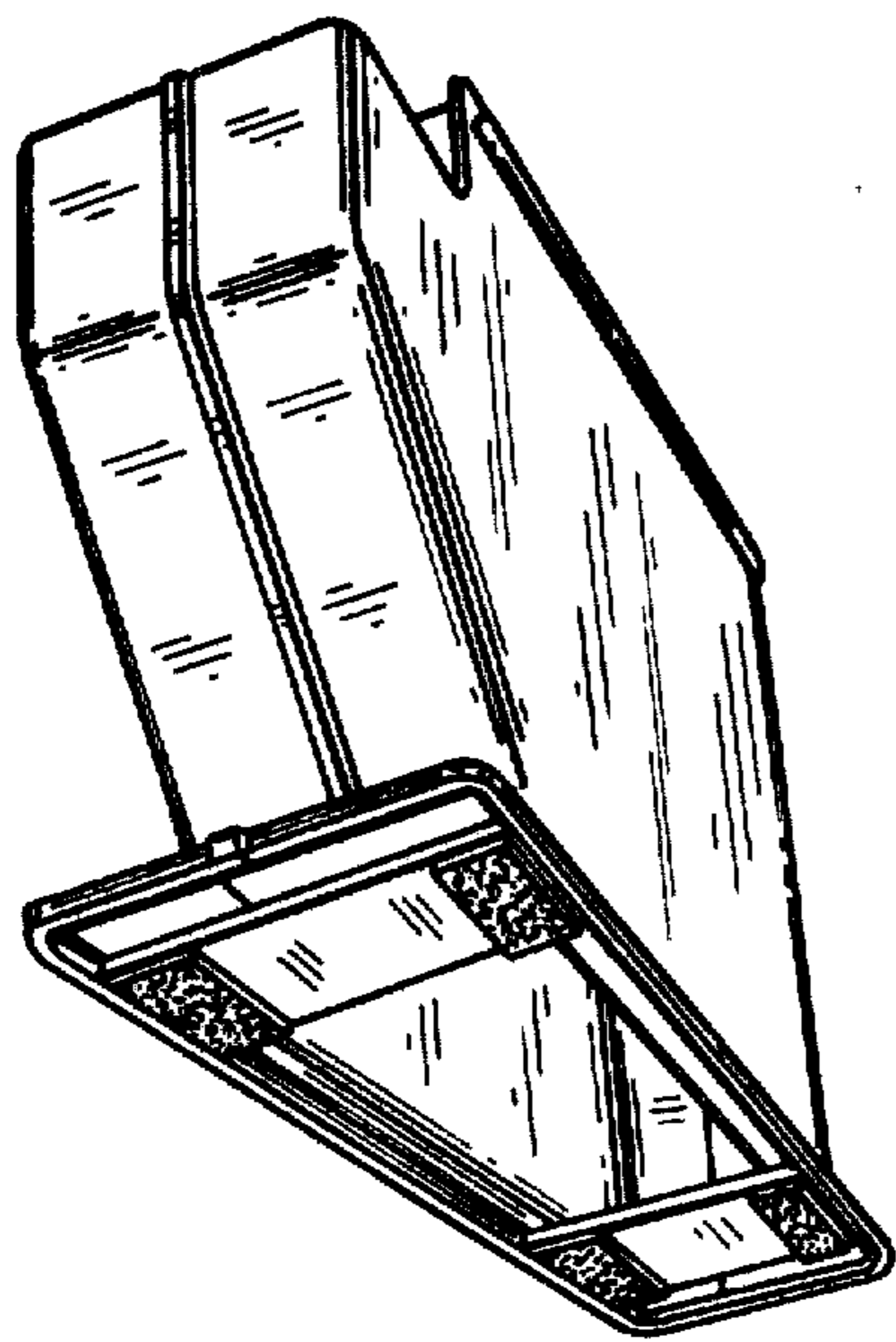

—FIG. 7

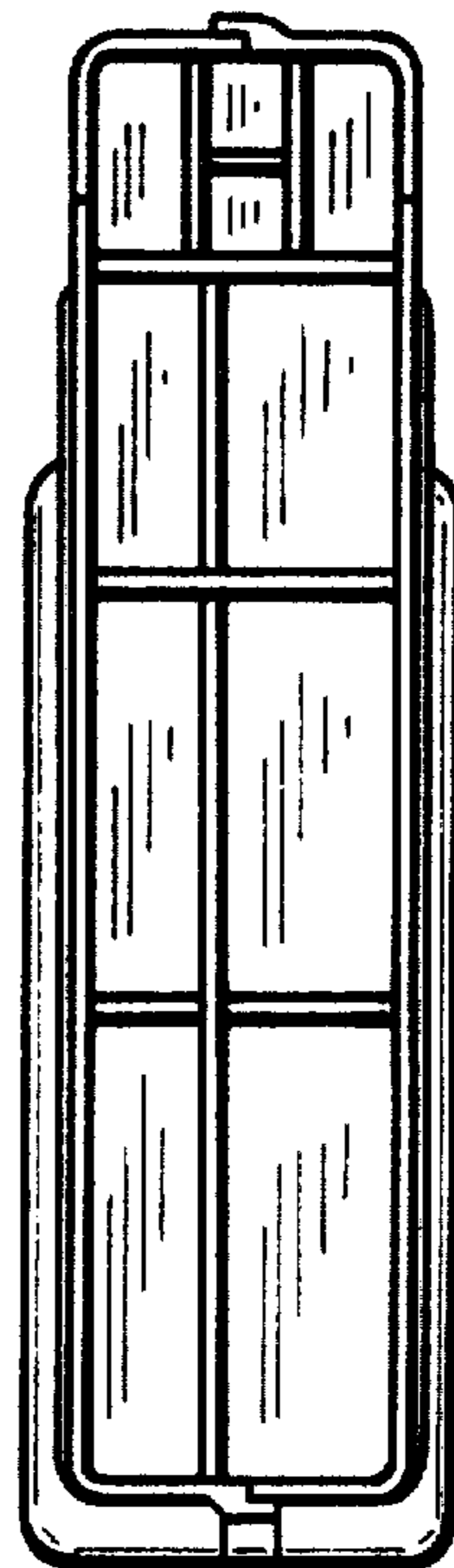

—FIG. 8

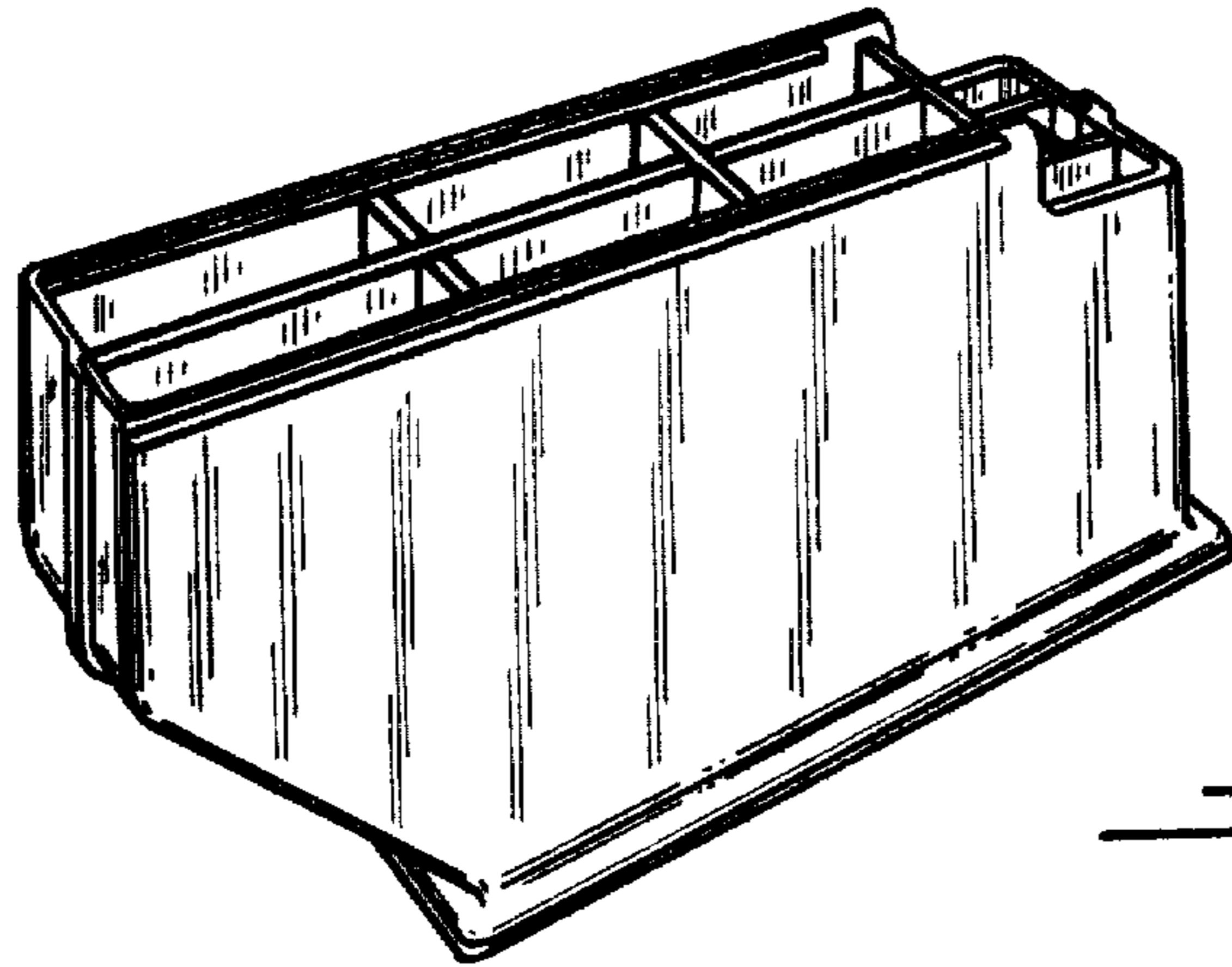

— FIG. 9

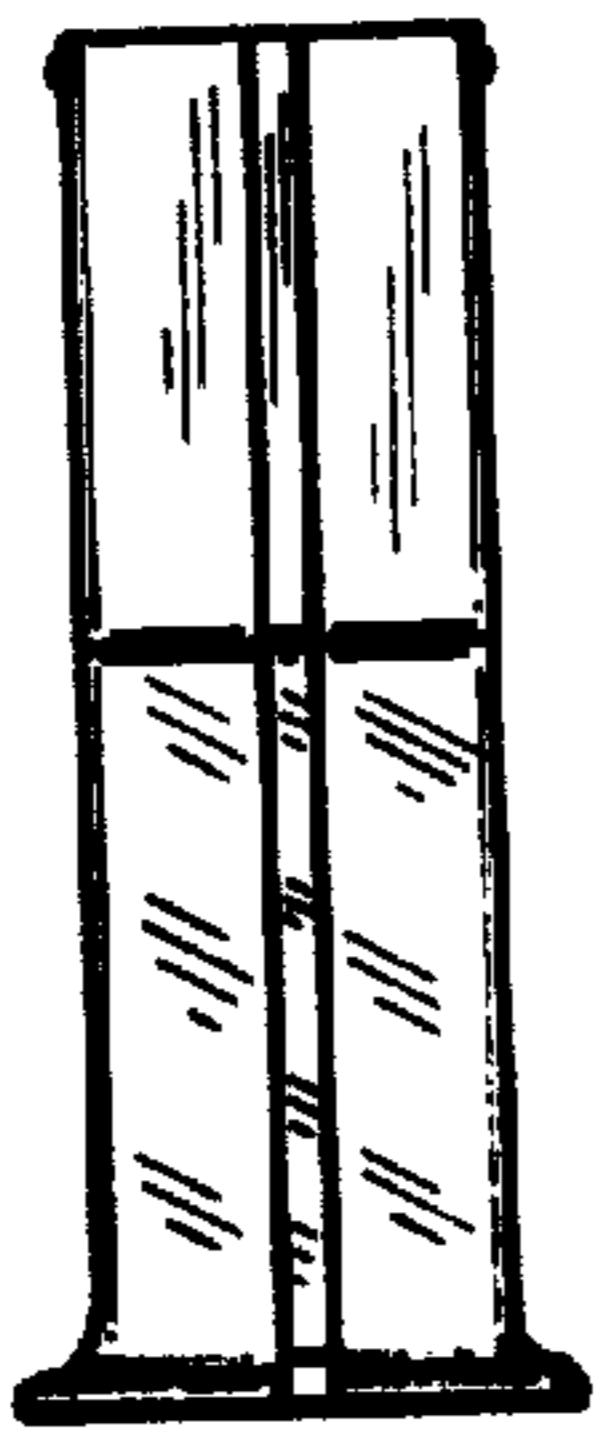

— FIG. 11

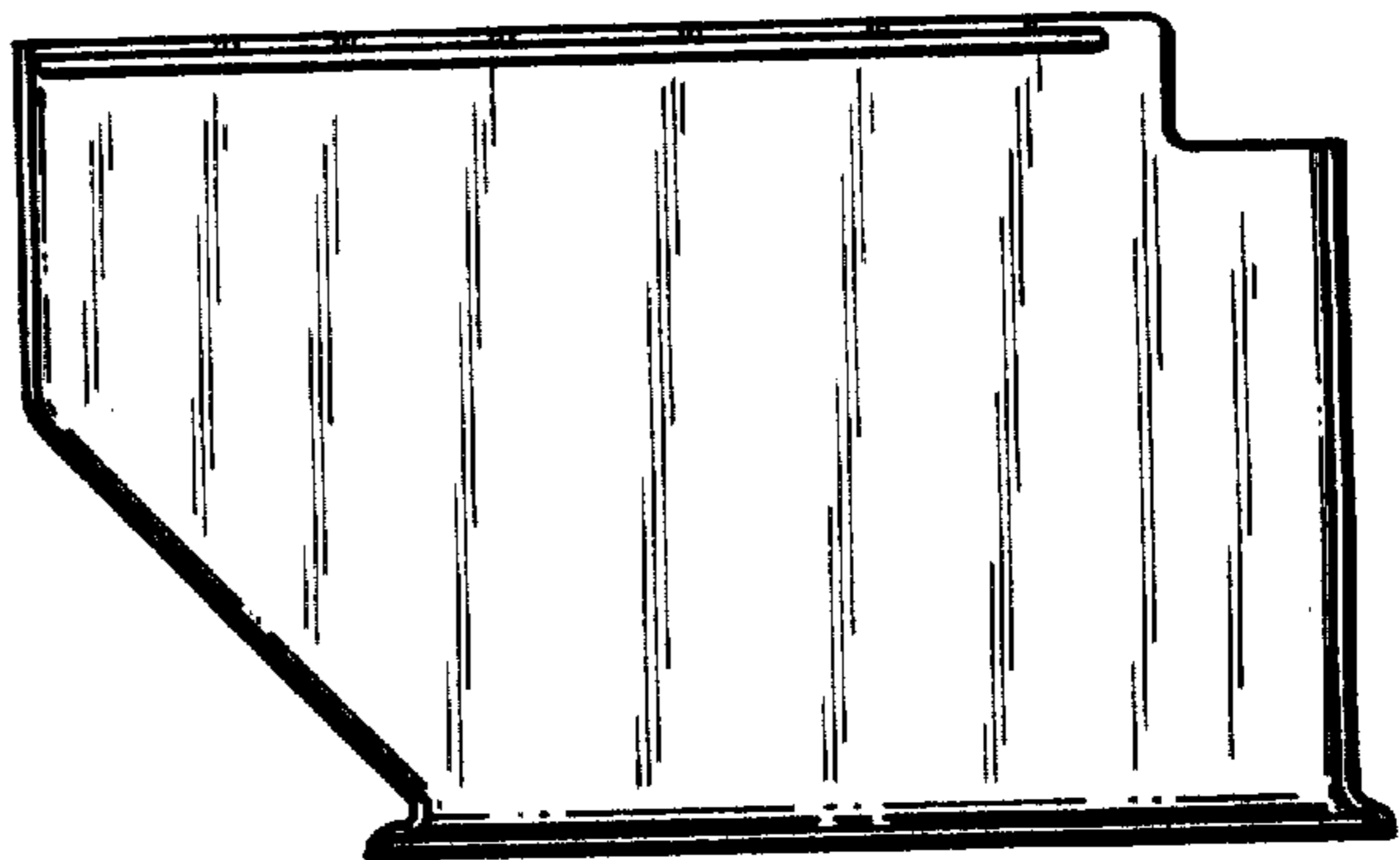

— FIG. 10

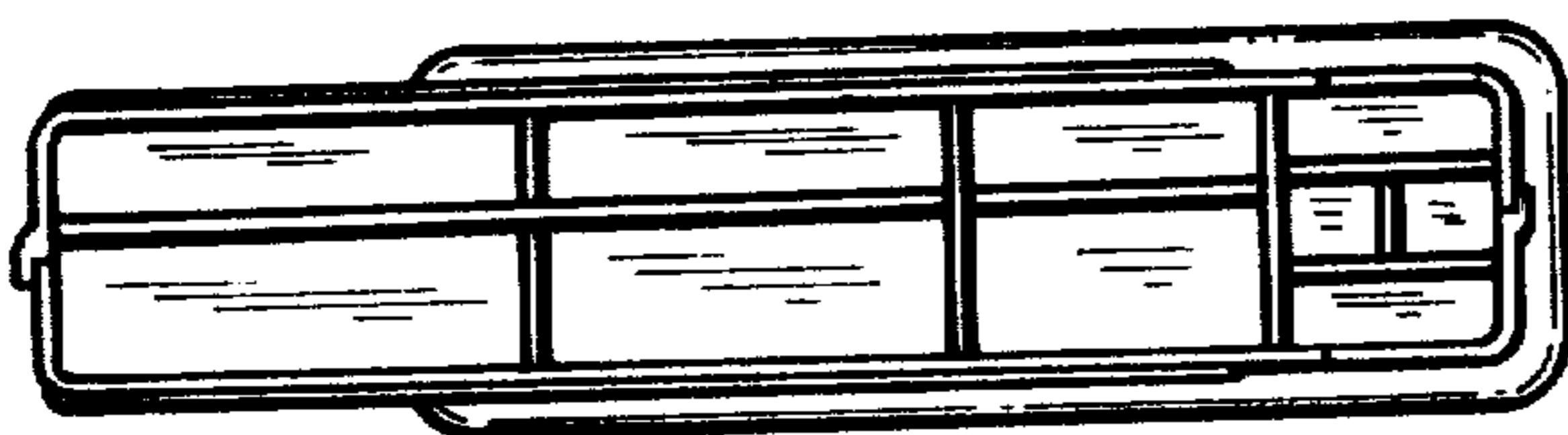

— FIG. 13

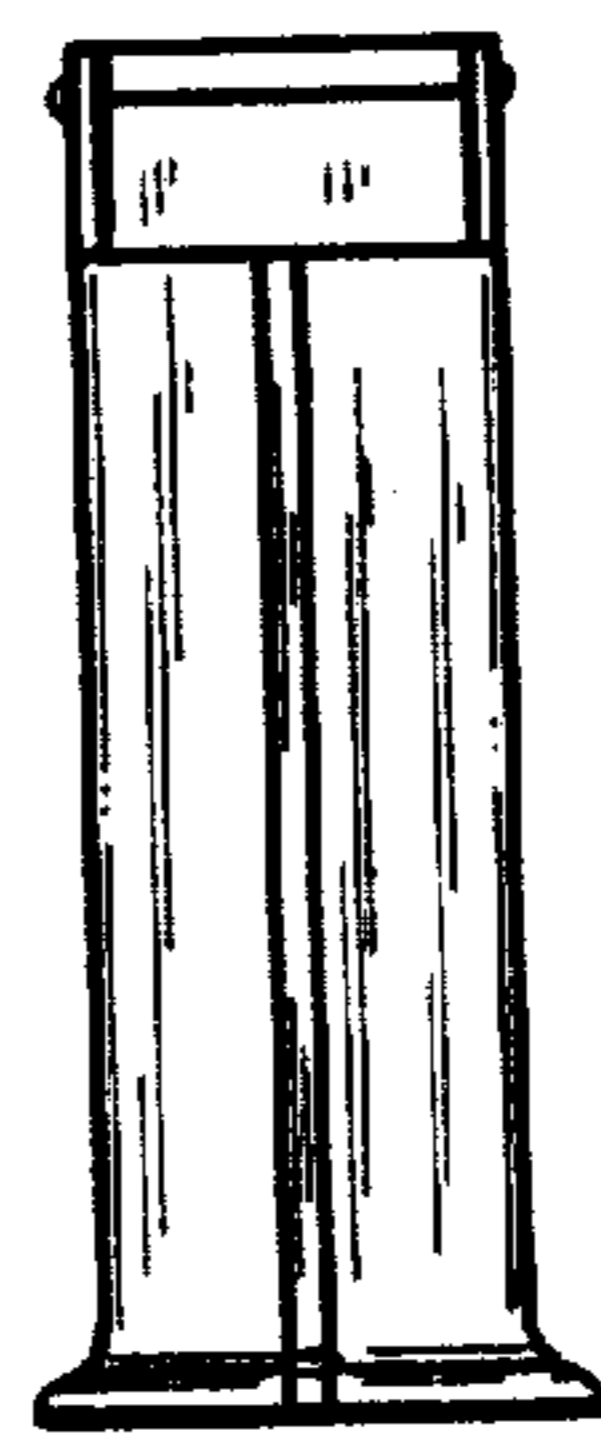

— FIG. 12