

[54] AIRPLANE

[76] Inventor: Perry B. Johnson, 169 N. Main St., Paterson, N.J. 07522

[*] Notice: The portion of the term of this patent subsequent to Jun. 30, 1995 has been disclaimed.

[**] Term: 14 Years

[21] Appl. No.: 165,362

[22] Filed: Jul. 2, 1980

[51] Int. Cl. D12-07

[52] U.S. Cl. D12/326; D12/341

[58] Field of Search D12/326, 341, 333; 244/12.4, 15, 56

[56] References Cited

U.S. PATENT DOCUMENTS

- D. 192,458 3/1962 Knauer et al. D12/326
- D. 259,713 6/1981 Johnson D12/326

Primary Examiner—Alan P. Douglas
Attorney, Agent, or Firm—Samuelson & Jacob

[57] CLAIM

The ornamental design for an airplane, substantially as shown and described.

DESCRIPTION

FIG. 1 is a top plan view of an airplane showing my new design;

FIG. 2 is a bottom plan view thereof;

FIG. 3 is a side elevational view thereof, the other side being identical;

FIG. 4 is a front elevational view thereof;

FIG. 5 is a rear elevational view thereof;

FIG. 6 is a top plan view similar to FIG. 1, but with the engines and supplemental wings in an alternate position;

FIG. 7 is a bottom plan view of FIG. 6;

FIG. 8 is a side elevational view of FIG. 6;

FIG. 9 is a front elevational view of FIG. 6; and

FIG. 10 is a rear elevational view of FIG. 6.

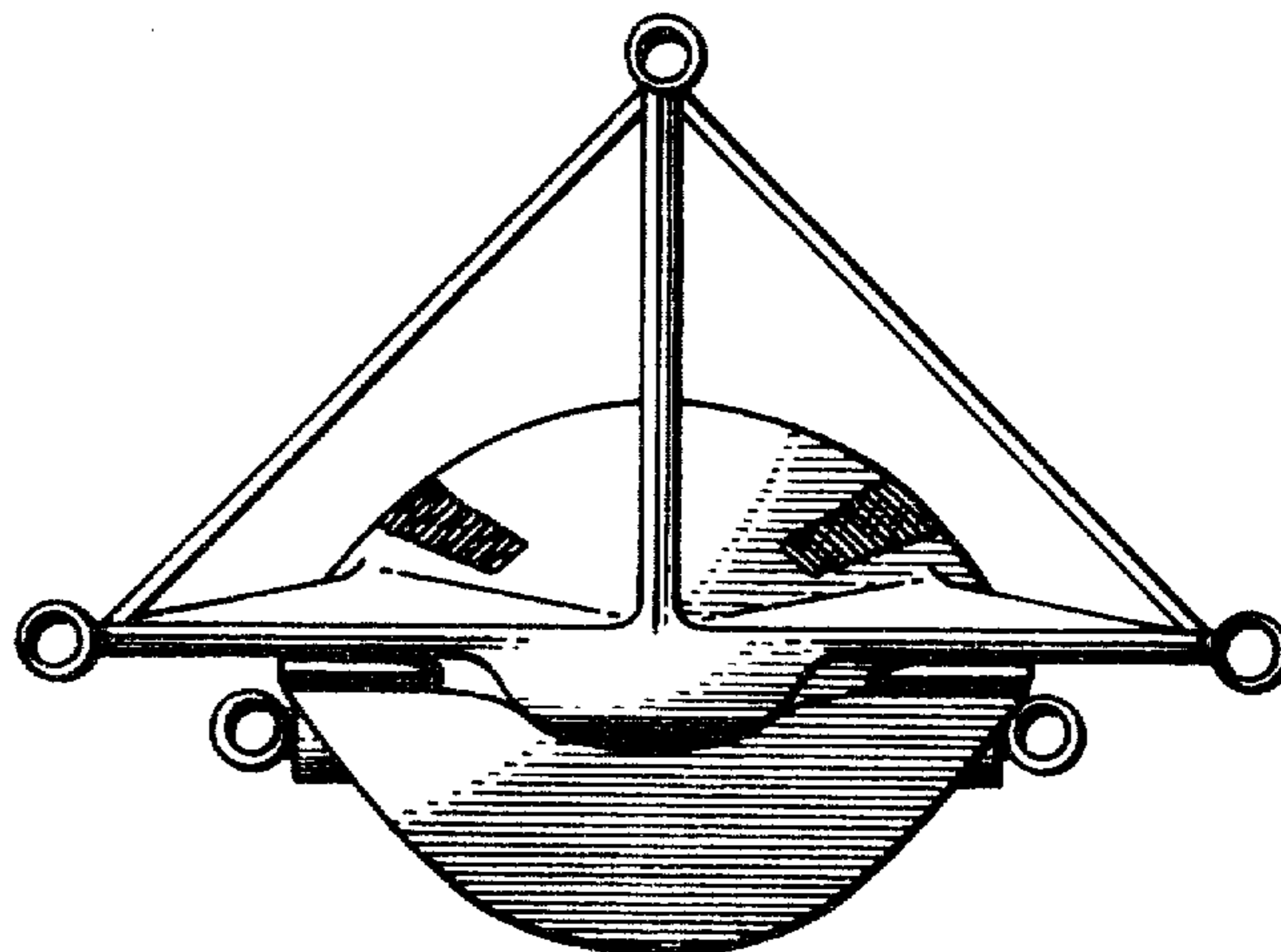
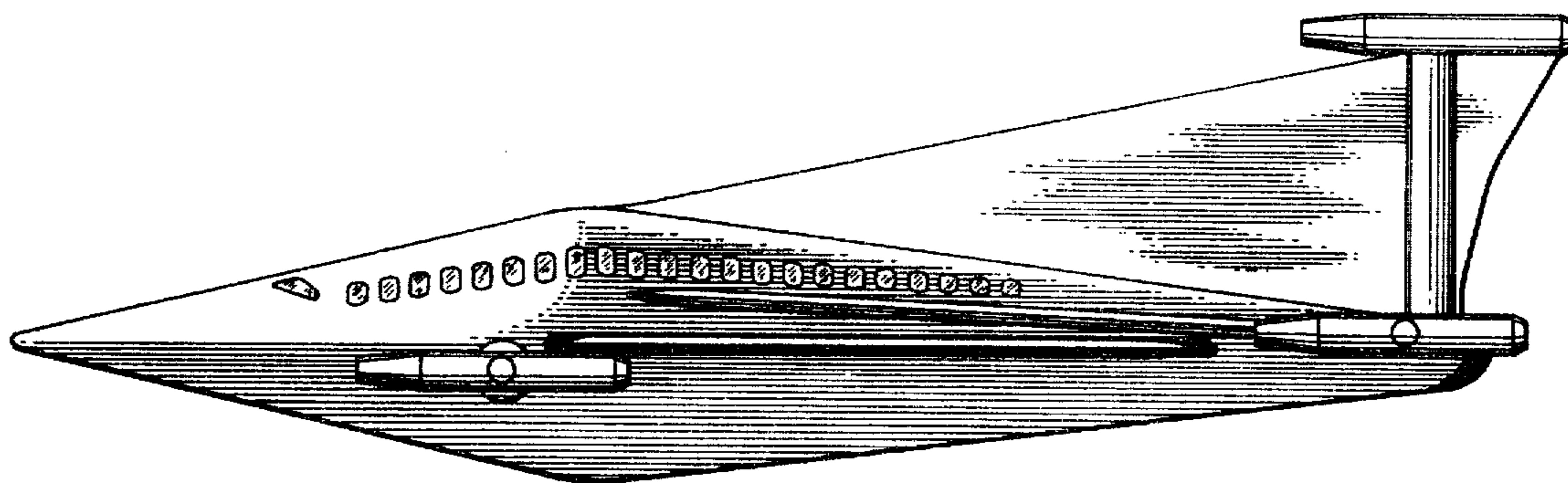

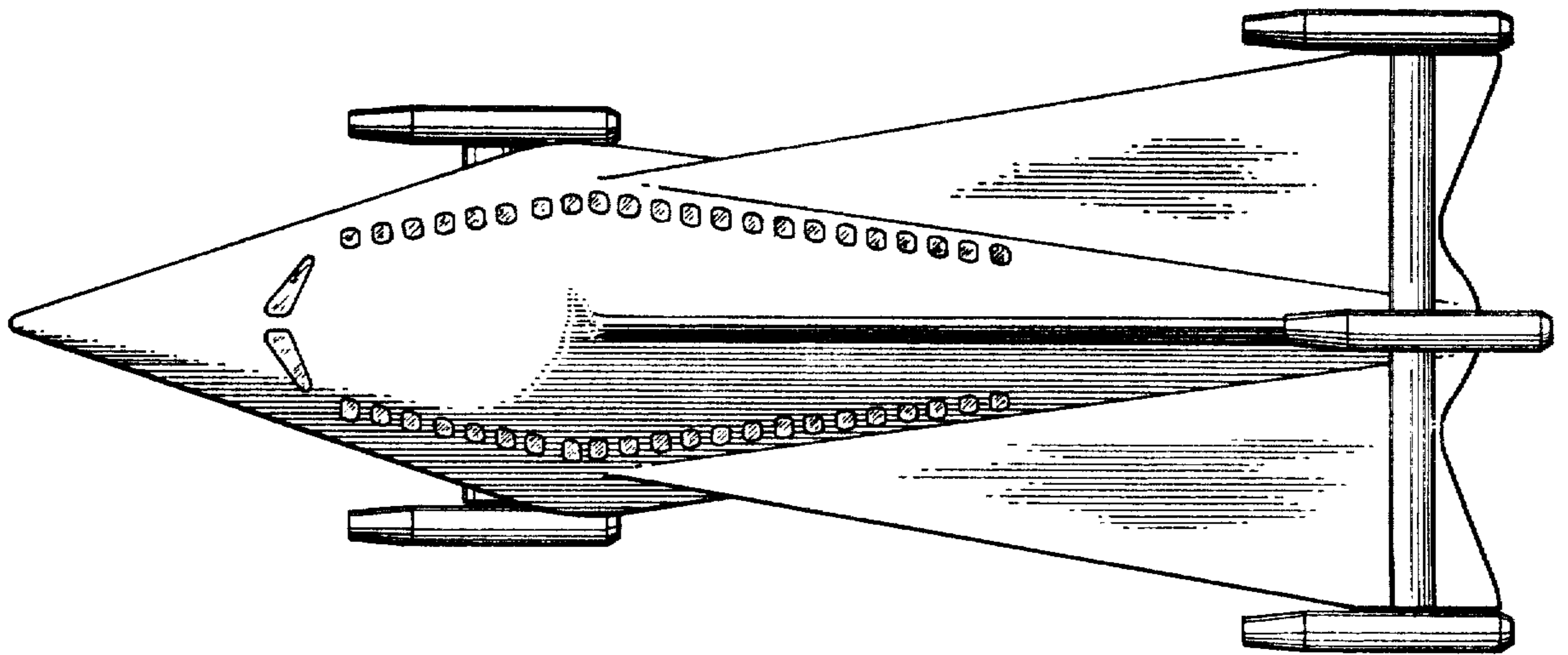

FIG. 1

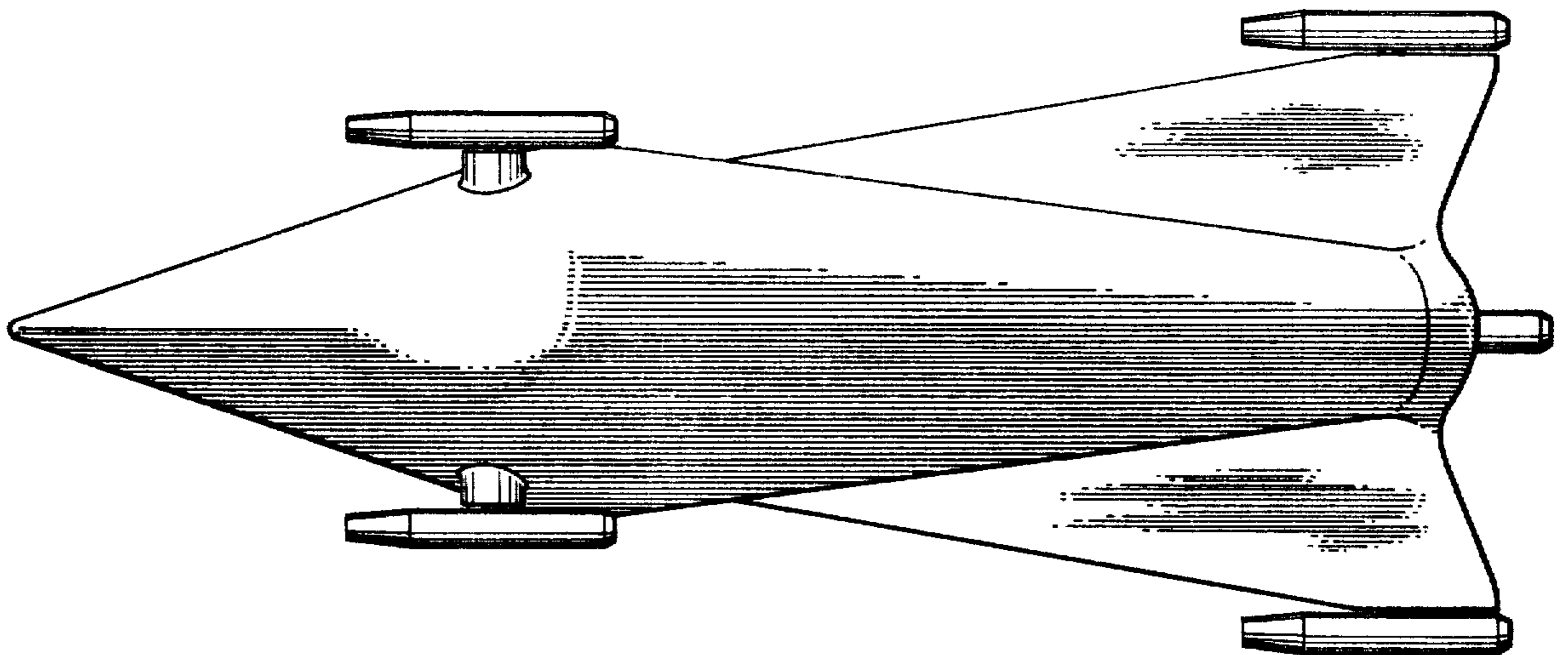

FIG. 2

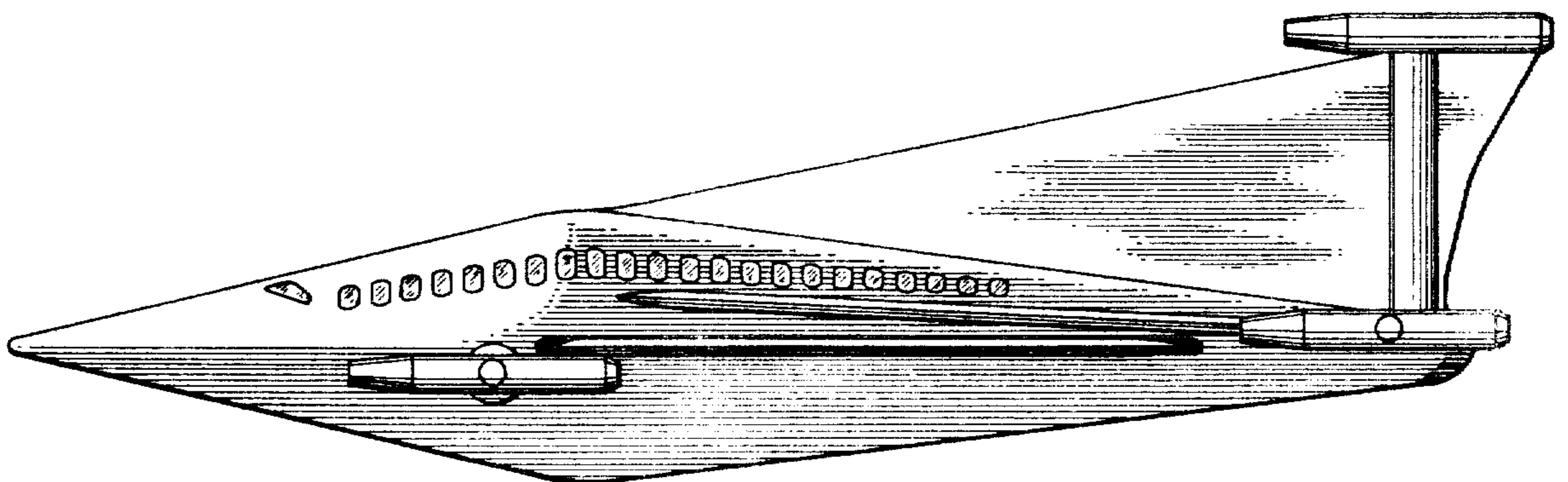

FIG. 3

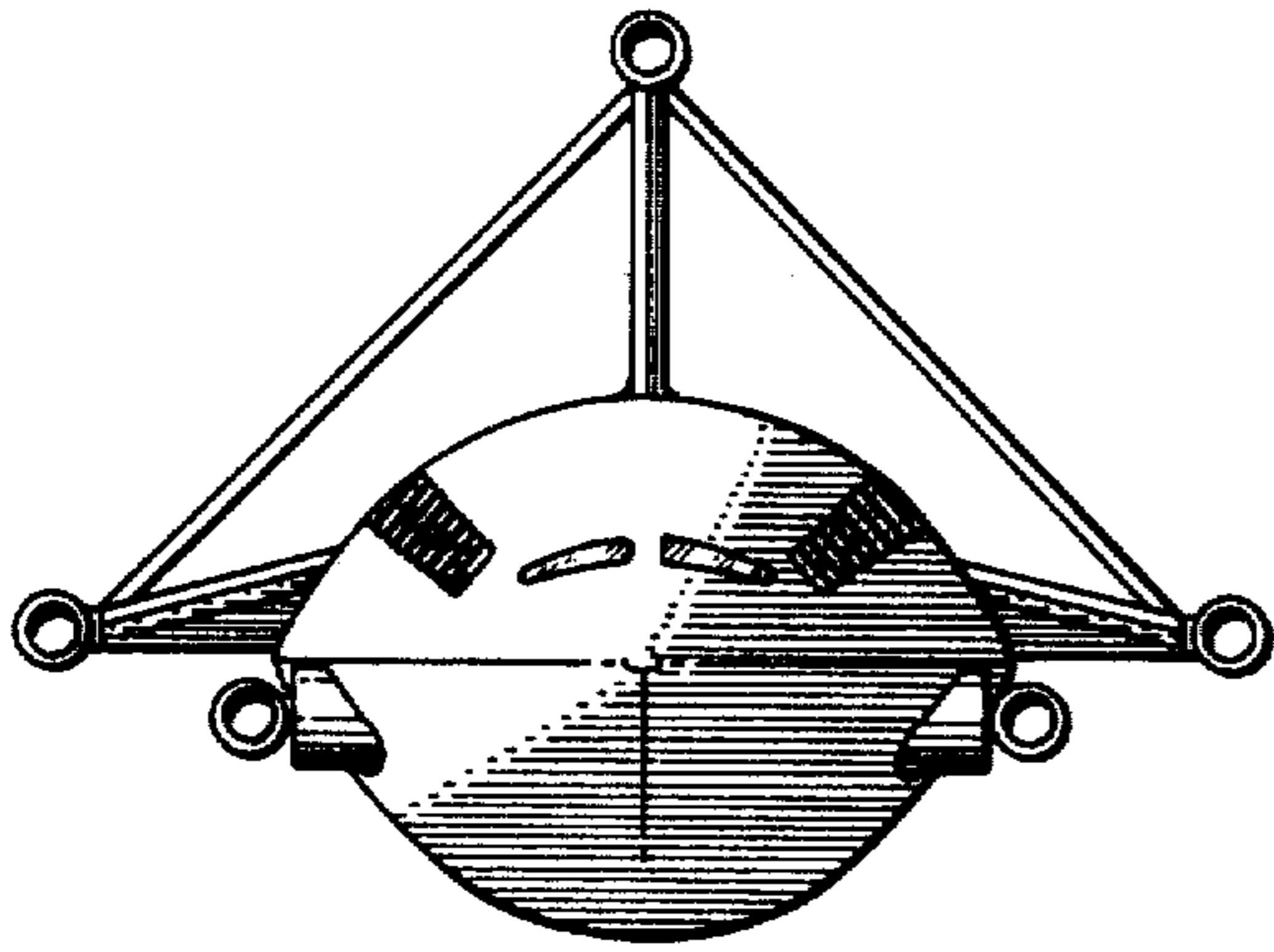

FIG. 4

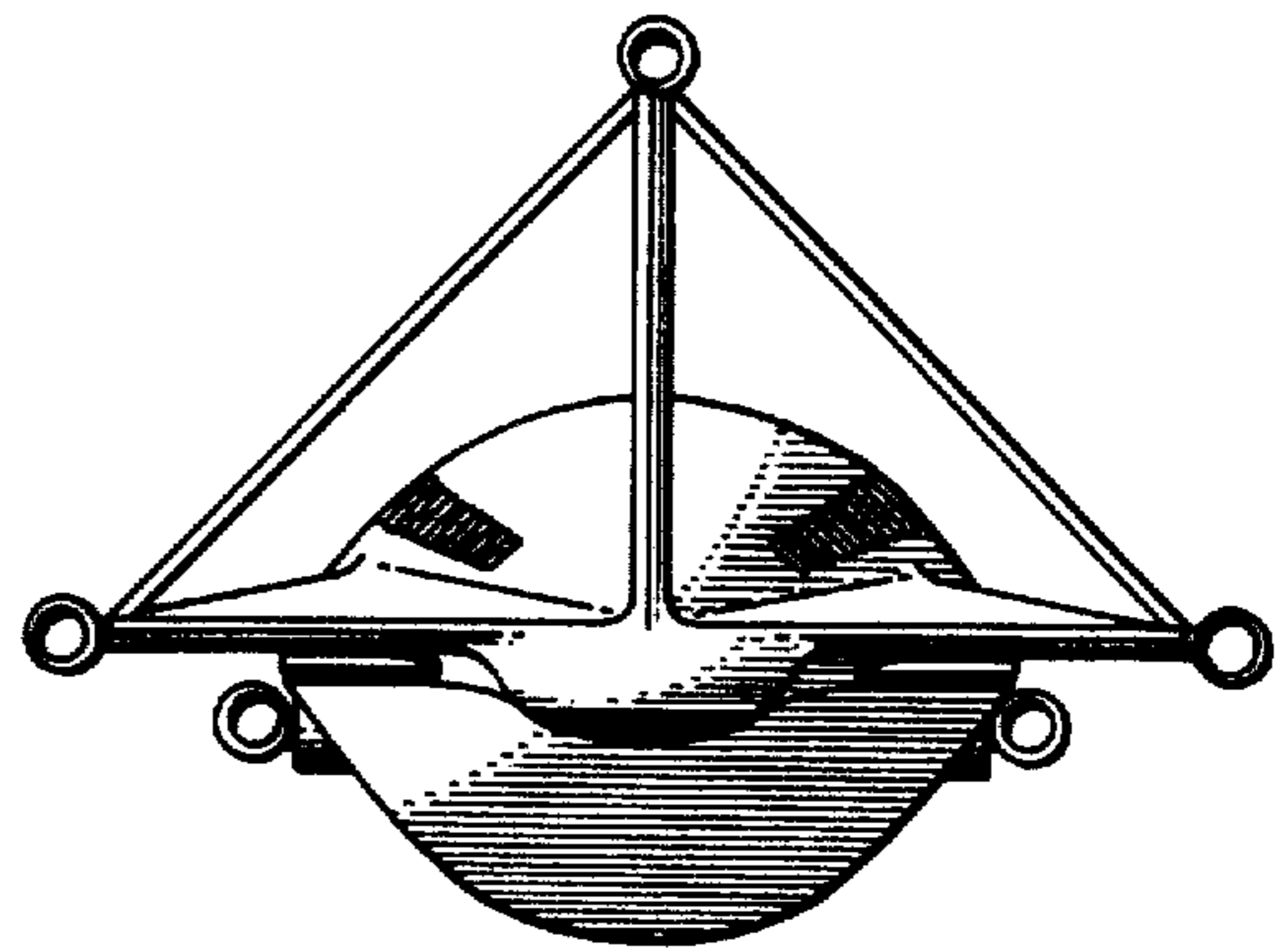

FIG. 5

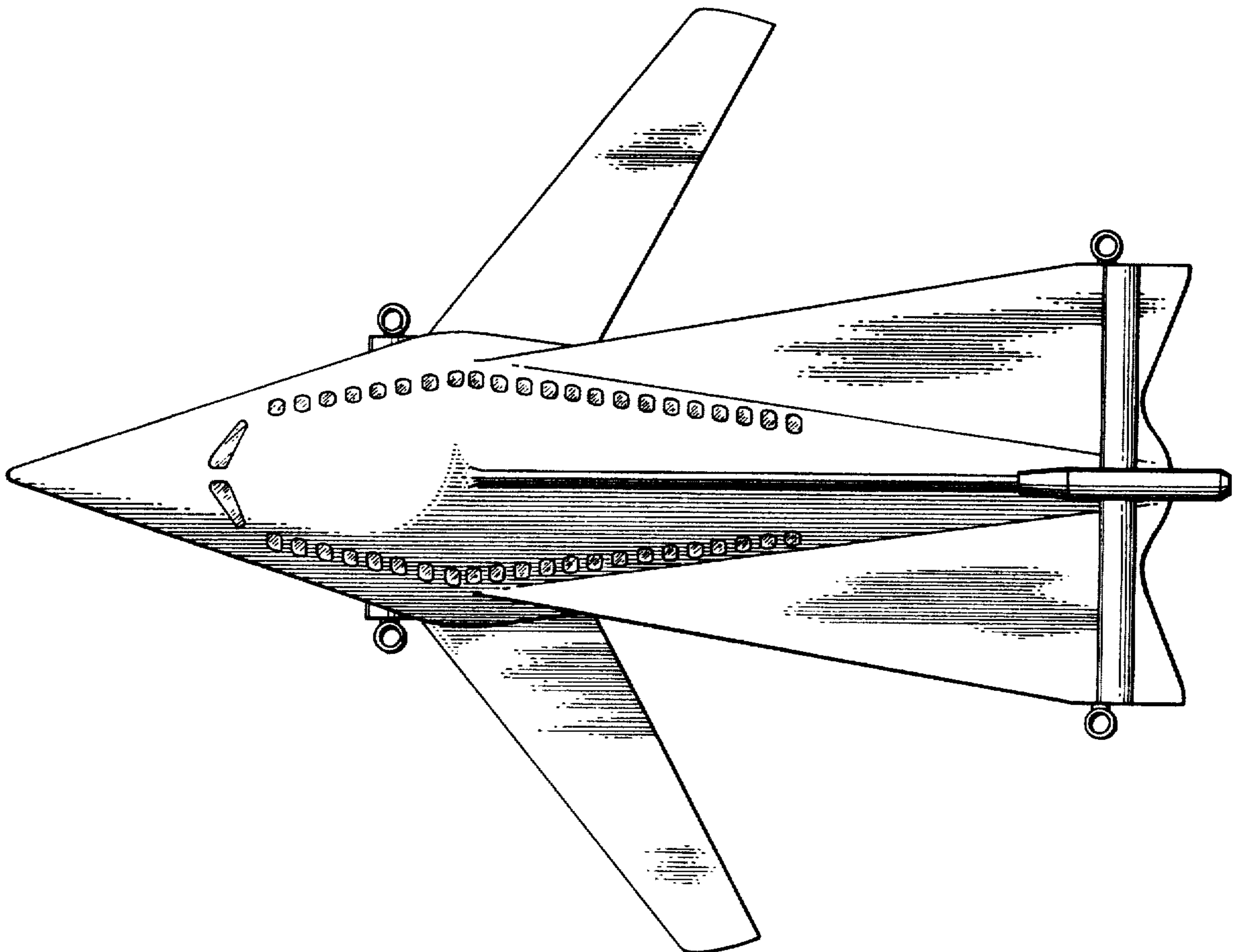

FIG. 6

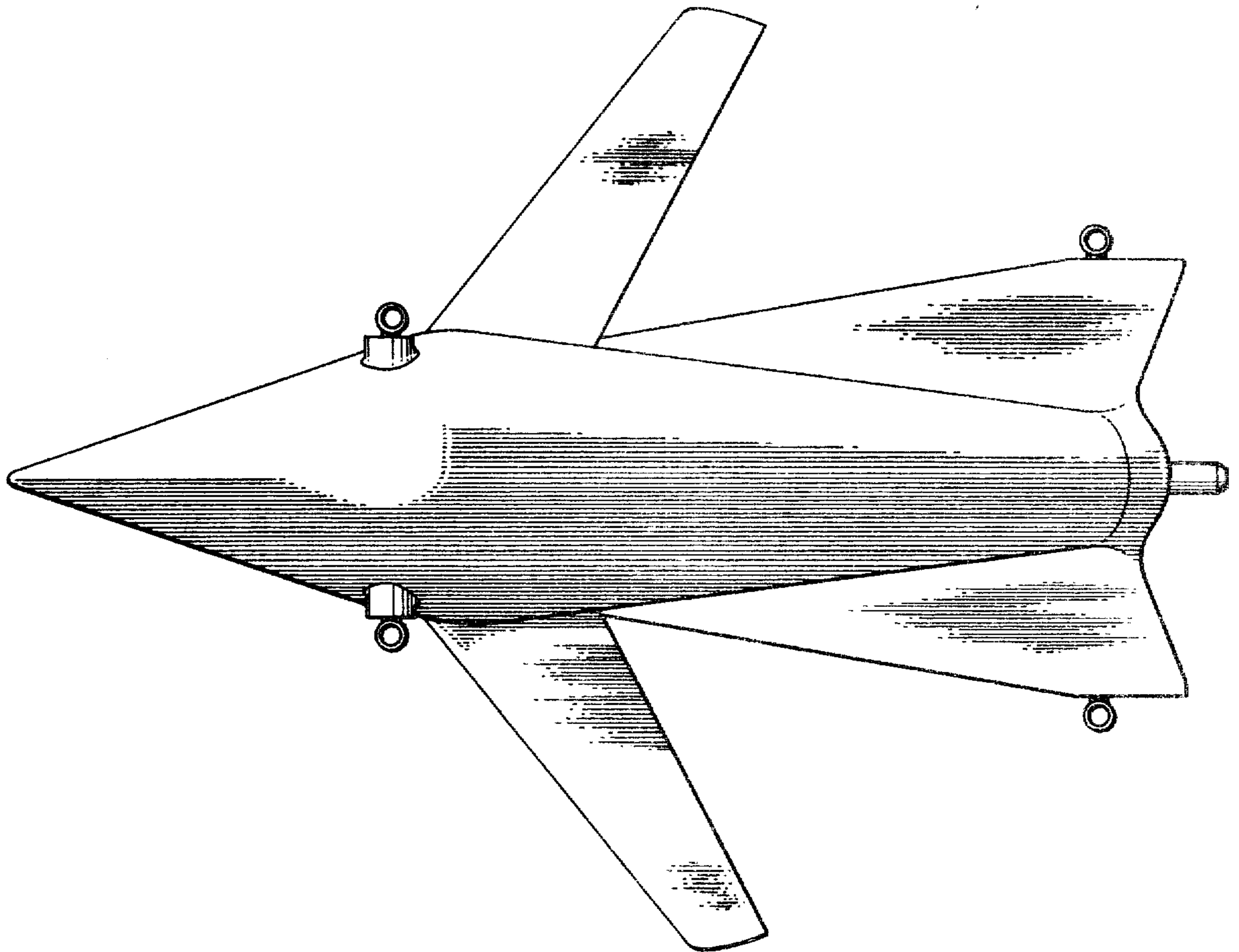

FIG. 7

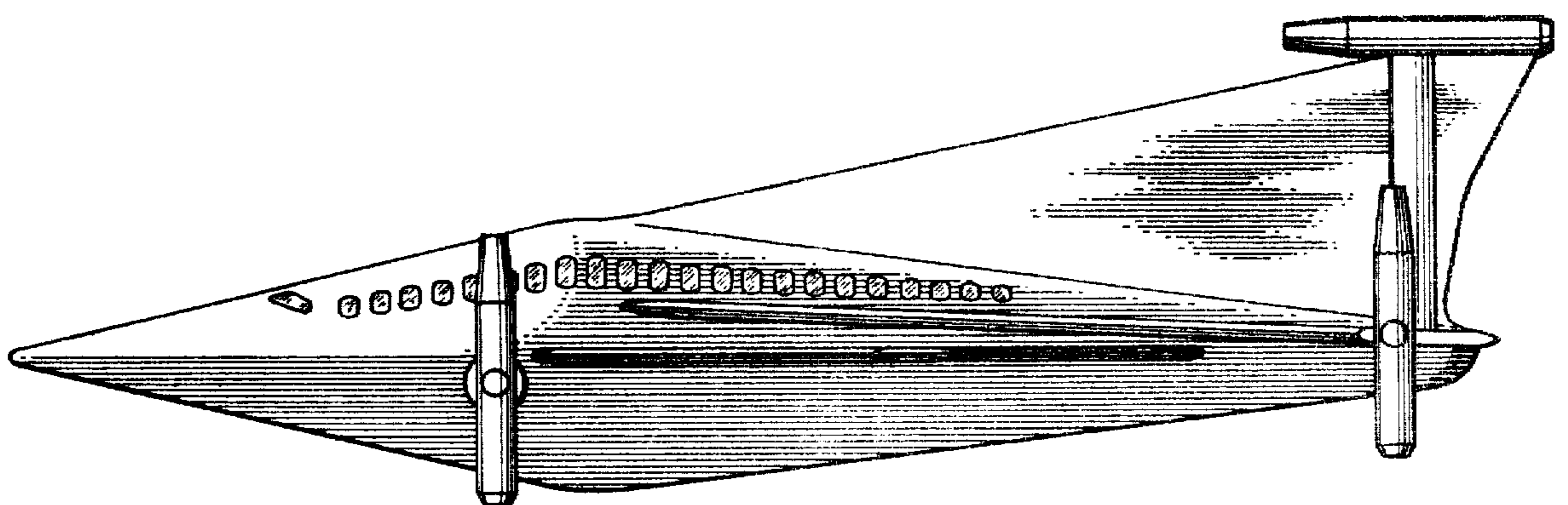

FIG. 8

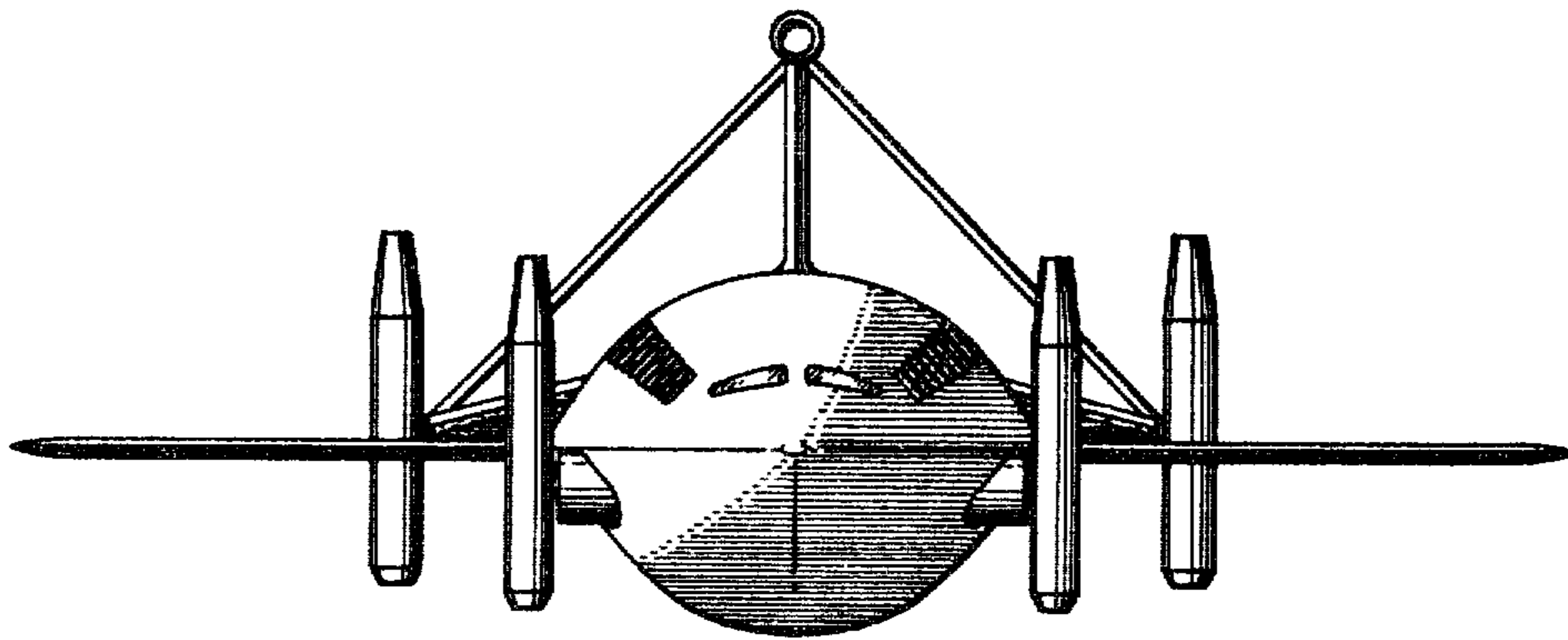

FIG. 9

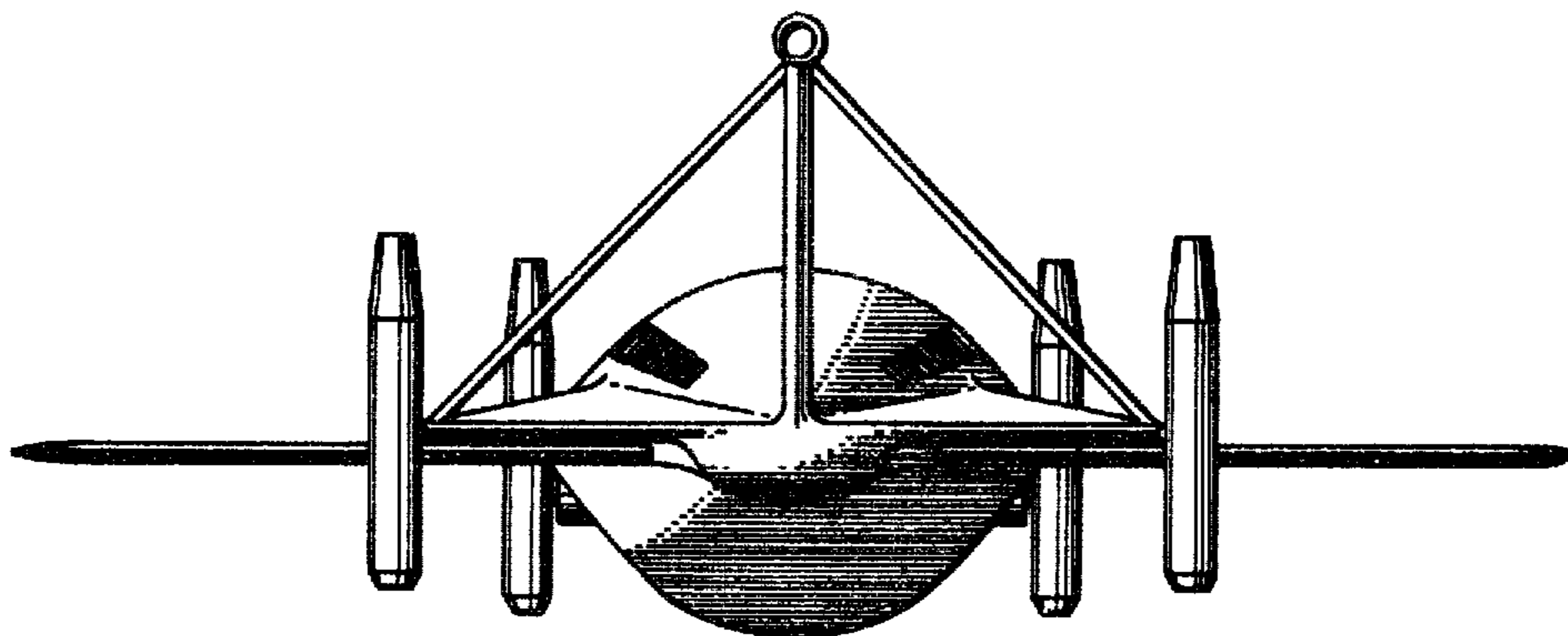

FIG. 10